

Longitudinal beam-based feedback system at the EuXFEL

Low Level RF Workshop 2022 – Contribution ID 35

Björn Lautenschlager on behalf of MSK - DESY

Hamburg, 13.10.2022

Outline

01 Introduction

02 Arrival time measurement and stabilization at the EuXFEL

03 Measurement results

04 Summary and Outlook

Introduction

EuXFEL facility

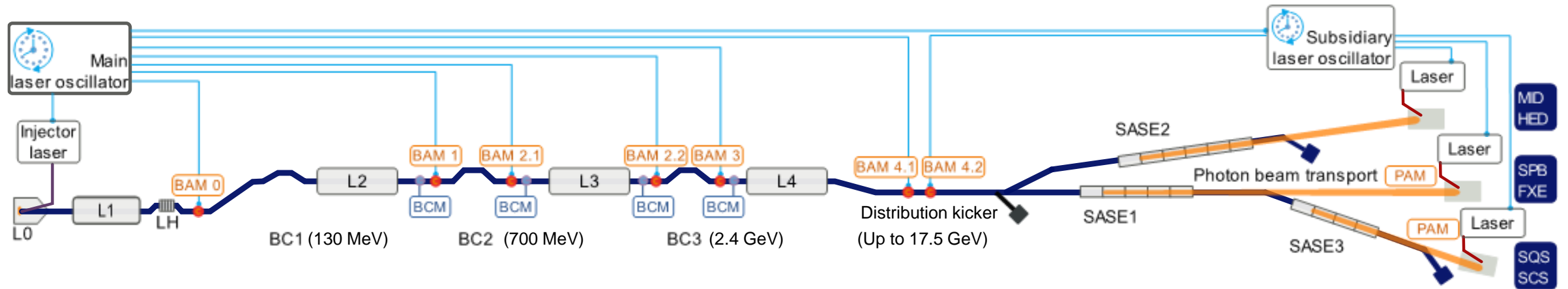

- Total length of 3.5 km
- 10 Hz burst mode
- Bunch repetition rate up to 4.5 MHz
- Total energy up to 17.5 GeV
- Charge usually 250 pC, partly 100 pC
- Three bunch compression chicanes BC1 to BC3
- Three photon beamlines

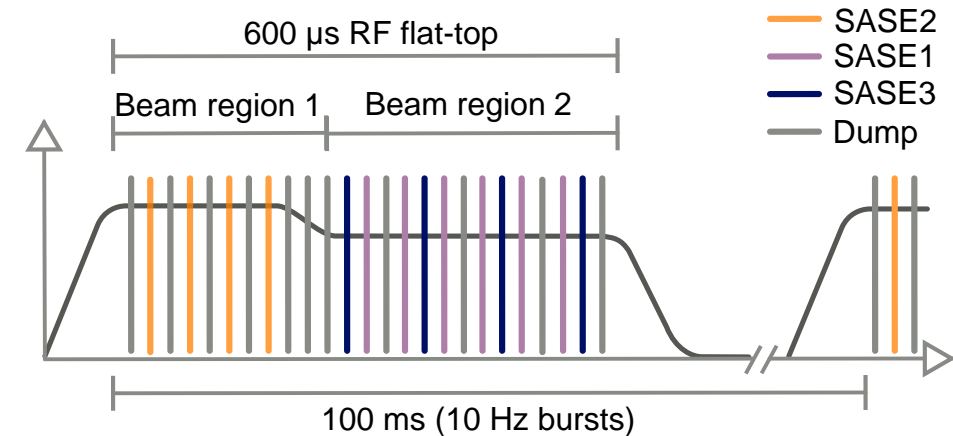

Arrival time measurement and stabilization at EuXFEL

Bunch arrival time monitor - BAM

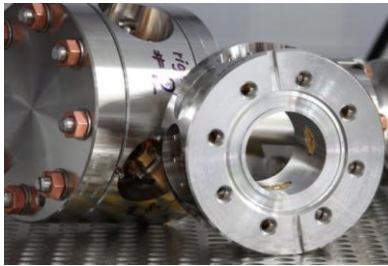
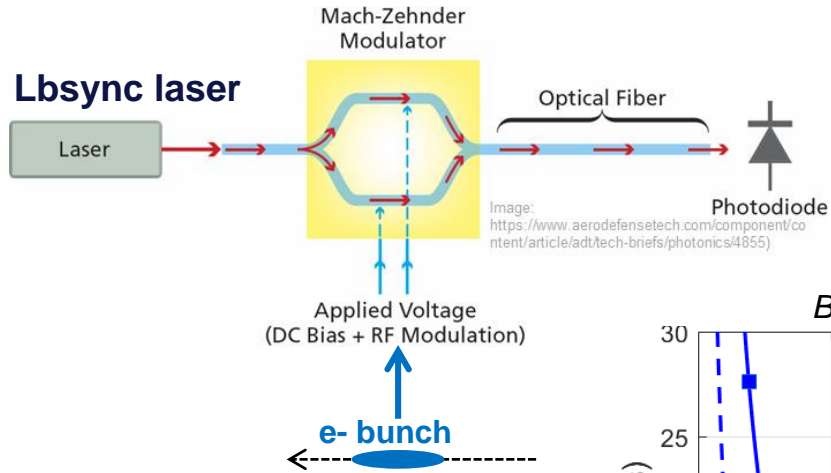

Slight dependence on beam position

2nd order effect
< 30 as / μm

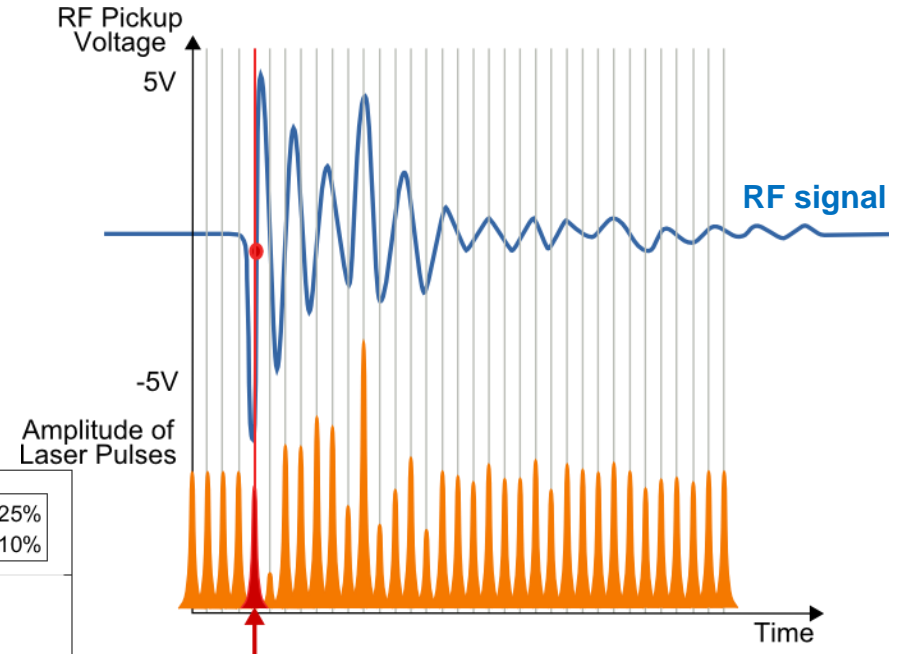
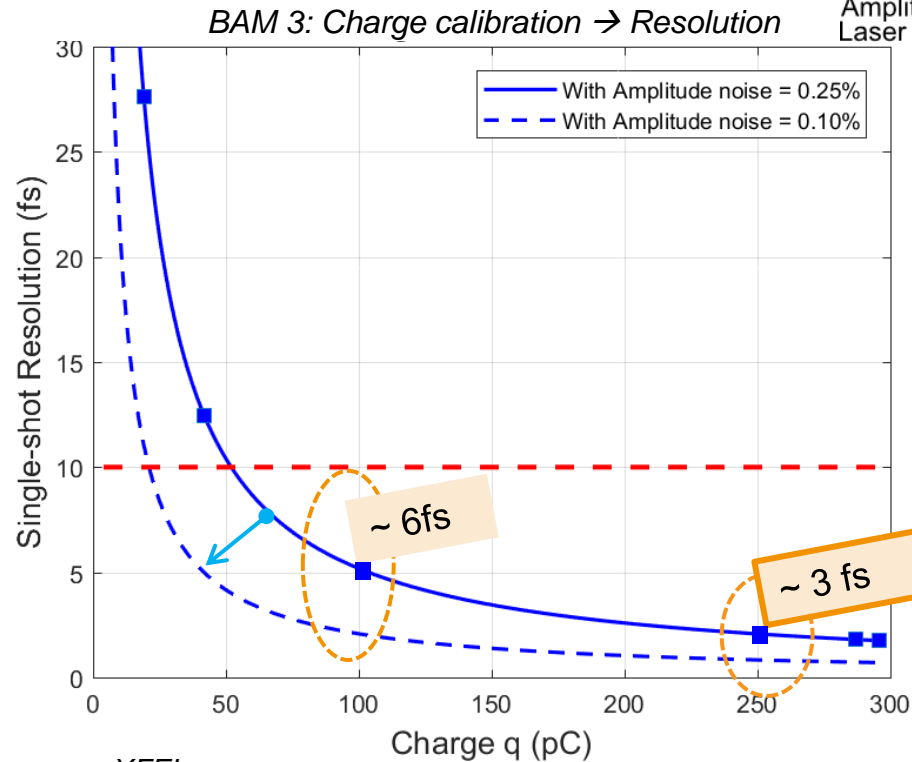

One laser pulse carries the arrival time information.

- Measurement of the relative arrival time

Bunch arrival time monitor

Measurement and jitter at EuXFEL

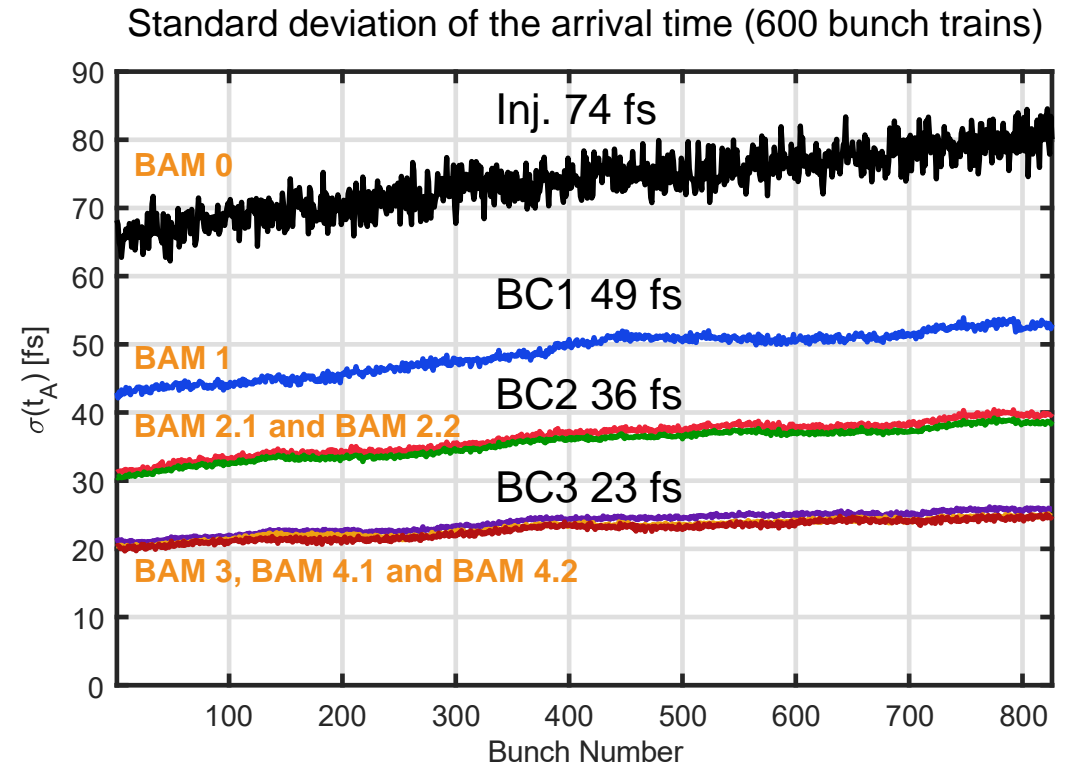
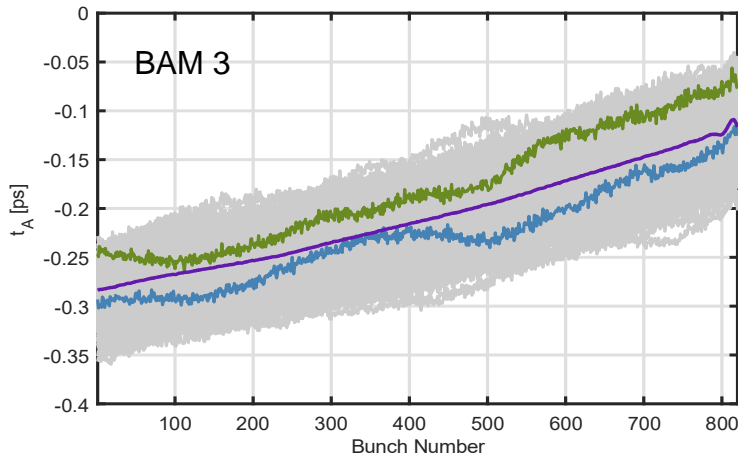
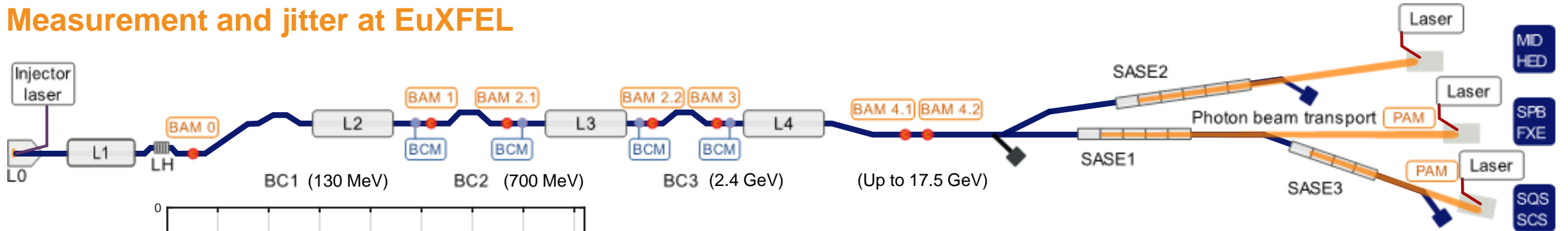

- Arrival time measurement of 600 bunch trains (gray lines)
- The arrival time jitter depends on the initial jitter $\Sigma_{t,i}$, the RF phase jitter σ_ϕ and the relative amplitude jitter $\frac{\sigma_v}{v}$

$$\Sigma_{t,f}^2 = \left(\frac{R_{56}}{c_0}\right)^2 \cdot \frac{\sigma_{V_1}^2}{V_1^2} + \left(\frac{C-1}{C}\right)^2 \cdot \frac{\sigma_{\phi_1}^2}{\omega_{rf}^2} + \left(\frac{1}{C}\right)^2 \cdot \Sigma_{t,i}^2$$

Different feedback loops at EuXFEL

Basic principle of the bunch compression chicane

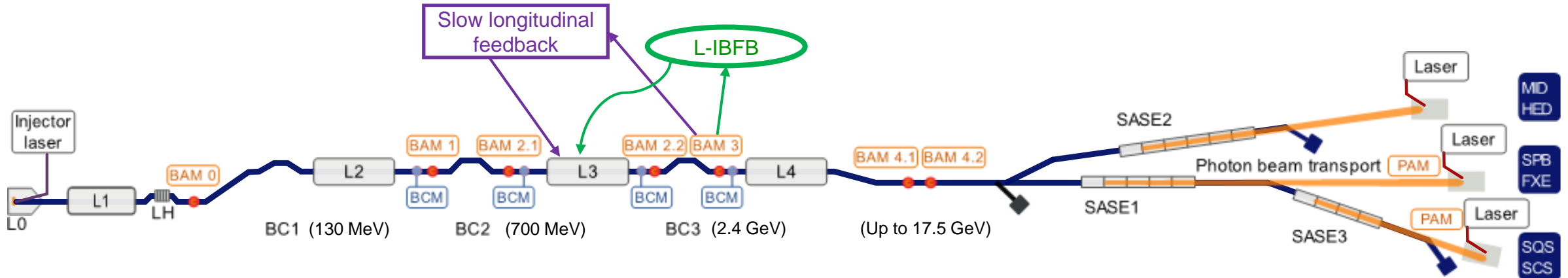

- Path length through the chicane depends on the energy: compression, arrival time
- Principle is used for different feedback loops.
 - Compensation of slow drifts (first bunch, server based), sumvoltage/chirp
 - Compensation of fluctuations along the bunch train (all bunches, firmware based), amplitude/phase, L-IBFB
- Feedback loops possible at all chicanes

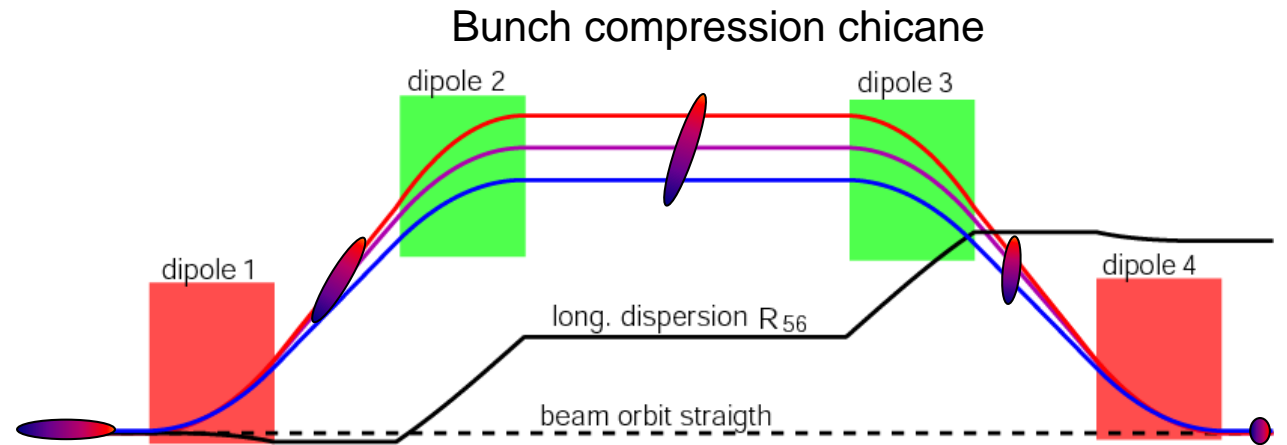

Courtesy: H. Schlarb

Feedback loops at EuXFEL

LLRF system as actuator

- LLRF: Control of the RF-field of the accelerator modules, Amplitude A and Phase φ
- Calculates drive signal for high power provided by the klystron
- Three different parts
 - Filling
 - Flat top (Beam regions), bunches are accelerated
 - Decay
- Different controller types like, multi-input multi-output or learning feedforward controller
- Many additional algorithms
BLC, DCM, ...



Feedback loops at EuXFEL

Longitudinal intra-bunch train feedback

- Data send via optical low-latency link
- Arrival time set point => arrival time control error
- LLRF system combines RF field error and beam based error
- LLRF controller runs as usual (FF, Feedback, LFF, ...)
- All action on firmware level (FPGA)
- Software/Server for general settings

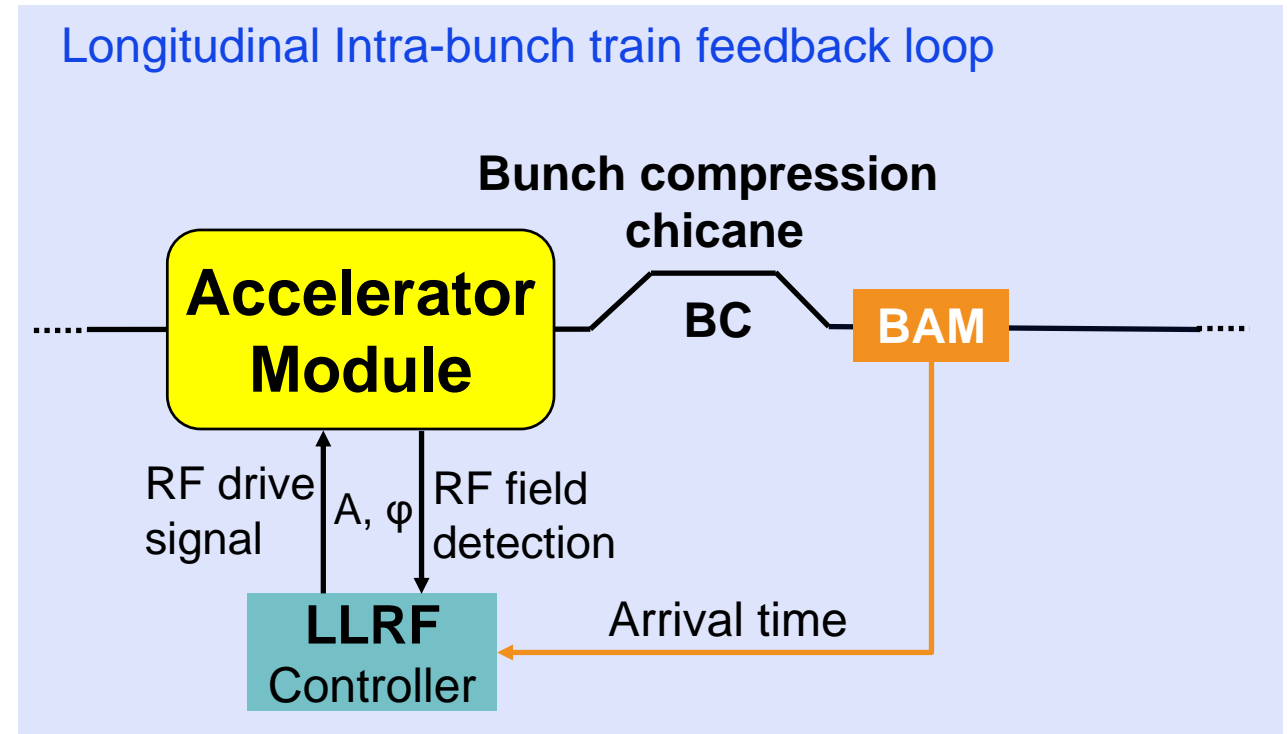

Feedback loops at EuXFEL

Longitudinal intra-bunch train feedback

- Data send via optical low-latency link
- Arrival time set point => arrival time control error
- LLRF system combines RF field error and beam based error
- LLRF controller runs as usual (FF, Feedback, LFF, ...)
- All action on firmware level (FPGA)
- Software/Server for general settings



Measurement results

Results EuXFEL

Feedback loops

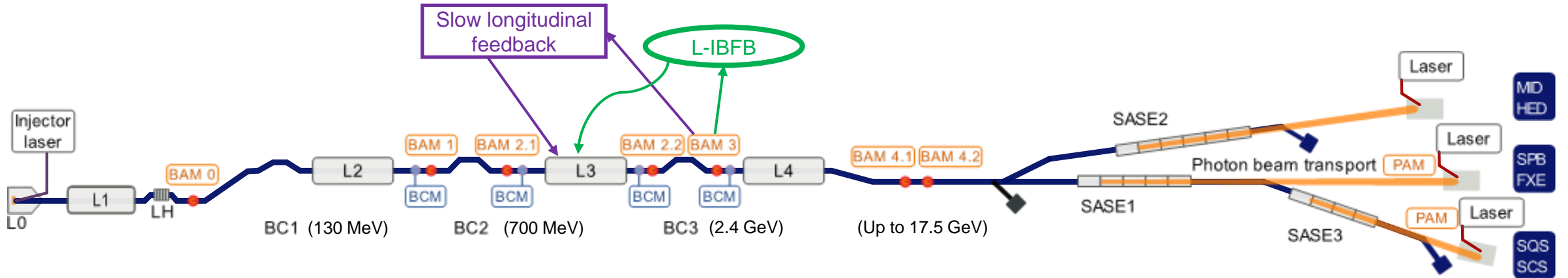

- L-IBFB loop around the third chicane
BAM 3 → A5.L3
- Slow arrival time feedback BAM 3 → Sumvoltage L3
- Data taken in parallel to user experiments
- Bunch-to-bunch repetition rate 2.25 MHz
- Bunch charge 250 pC

Results EuXFEL

L-IBFB at LLRF station A5

- Arrival time of more than 800 bunches
- 600 bunch-trains (gray lines)

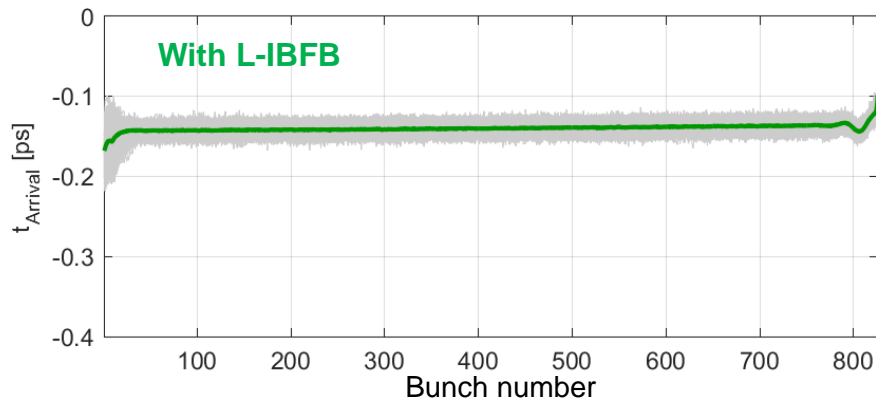
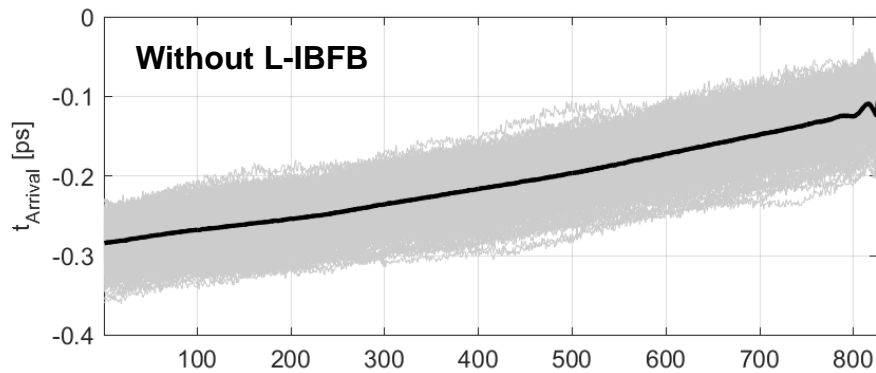

- L-IBFB pushes arrival time stabilities down to 5.5 fs.
- Steady state value reached after 10-15 μs

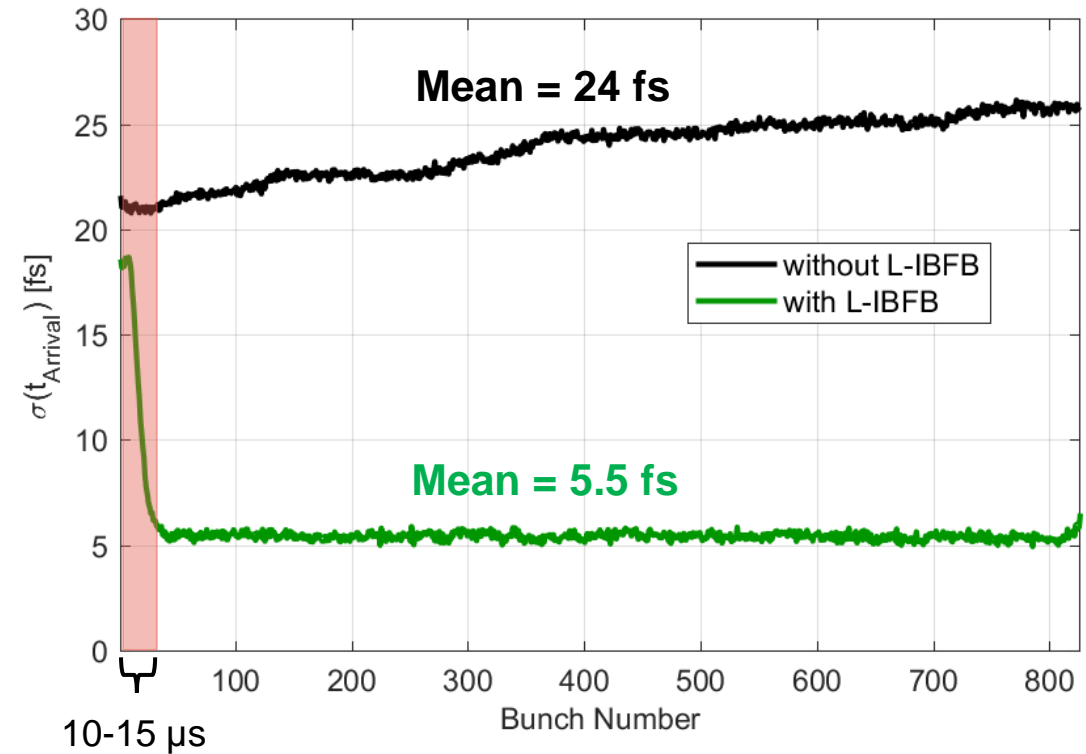

Results EuXFEL

Long term drifts due to ground motion under investigation

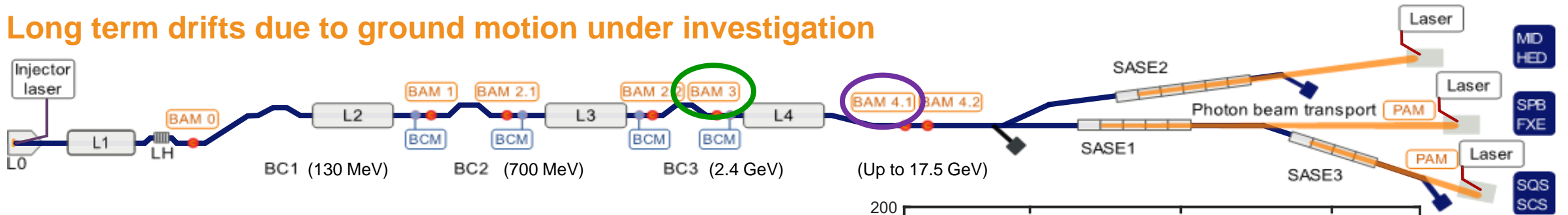

- L-IBFB at A5 runs stable over days, BAM 3
- Drifts measured with the BAM 4.1 (4.2)
- Distance between BAM 3 and BAM 4.1(4.2) 1.5 km – lengthening effect
- Period of ~12 hours
- Tide measured near Helgoland (north sea)
- Distance to the north sea ~100 km
- Under investigation

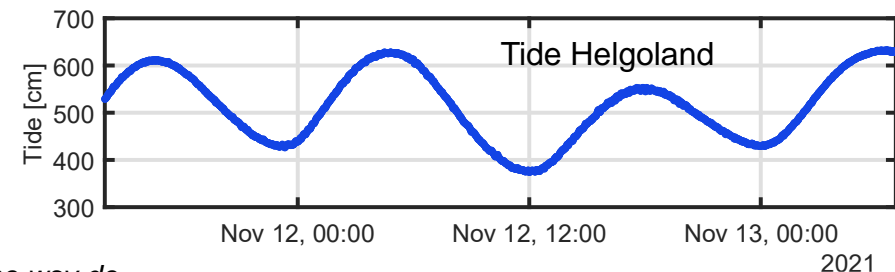
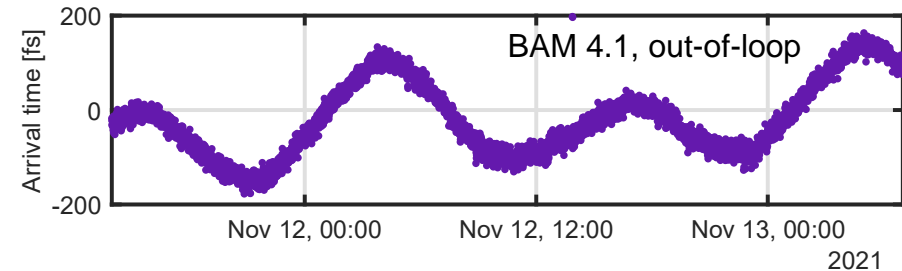
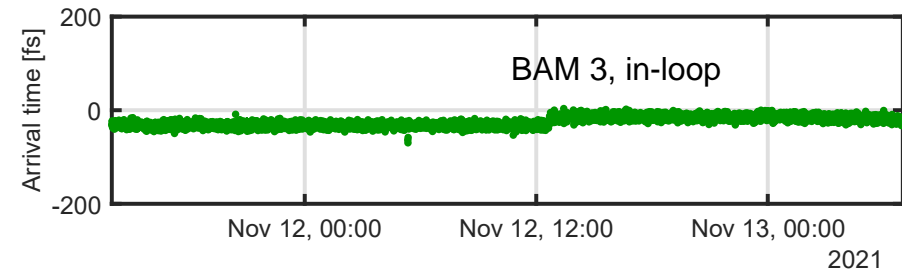

Source tidal data: www.pegelonline.wsv.de

B. Lautenschlager et al Achievements and challenges for sub-10 fs long-term arrival time stability for large scale SASE

Summary and Outlook

Summary and Outlook

- BAM reaches resolution down to 3-4 fs.
- Arrival time stabilities down to 5 fs (rms).
- The L-IBFB loop BAM 3 → A5.L3 runs stable over days. Available for daily operation.
- Long term drifts due to ground motions (tidal effect) but also other aspects of ground motion – disturbances coming from the oceans.
- Three new BAMs close to the experiments.
- L-IBFB: include compression signal
- Improve automation

Thank you

Contact

DESY. Deutsches
Elektronen-Synchrotron

www.desy.de

Björn Lautenschlager
– MSK – Maschine Strahlkontrollen
E-Mail: bjoern.lautenschlager@desy.de
Phone +49 (0) 40 8998-5453