

PAUL SCHERRER INSTITUT



Malek Haj Tahar

Probing the losses for a high power beam in view of the IMPACT project

GFA Accelerator Seminar, 26.09.2022

Overview

- **Implementation: original idea of D. Reggiani to use BDSIM/GEANT4, support from J. Snuverink**
- **Challenges: uncertainties of the developed model for HIMB TgH**
- **Approach to probe the losses**
- **Benchmarking results and outcome**
- **HIMB case**
- **What next?**

Overview – SINQ beamline 1/2

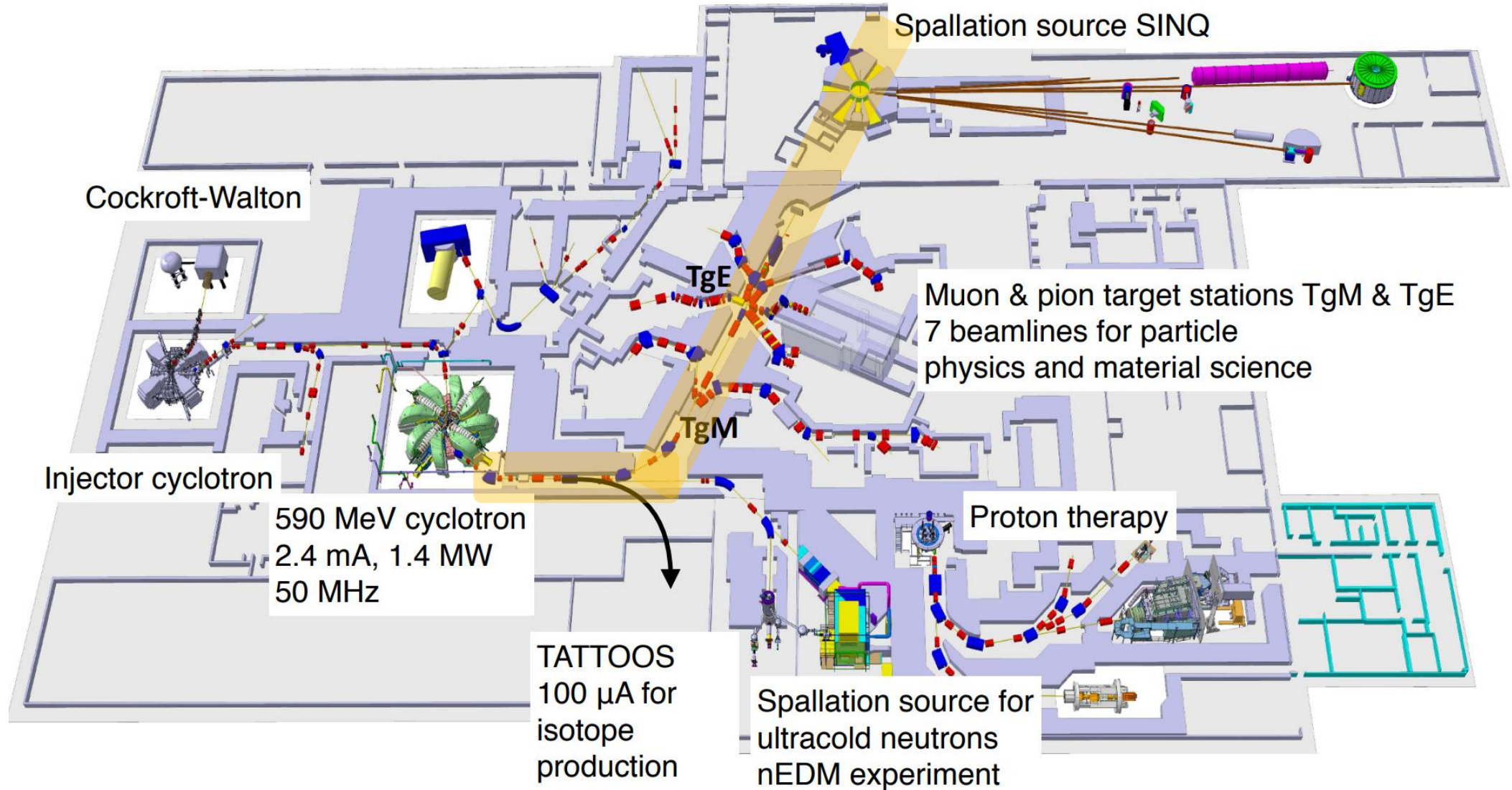

Overview – SINQ beamline 2/2

New implementation of SINQ beamline in BDSIM

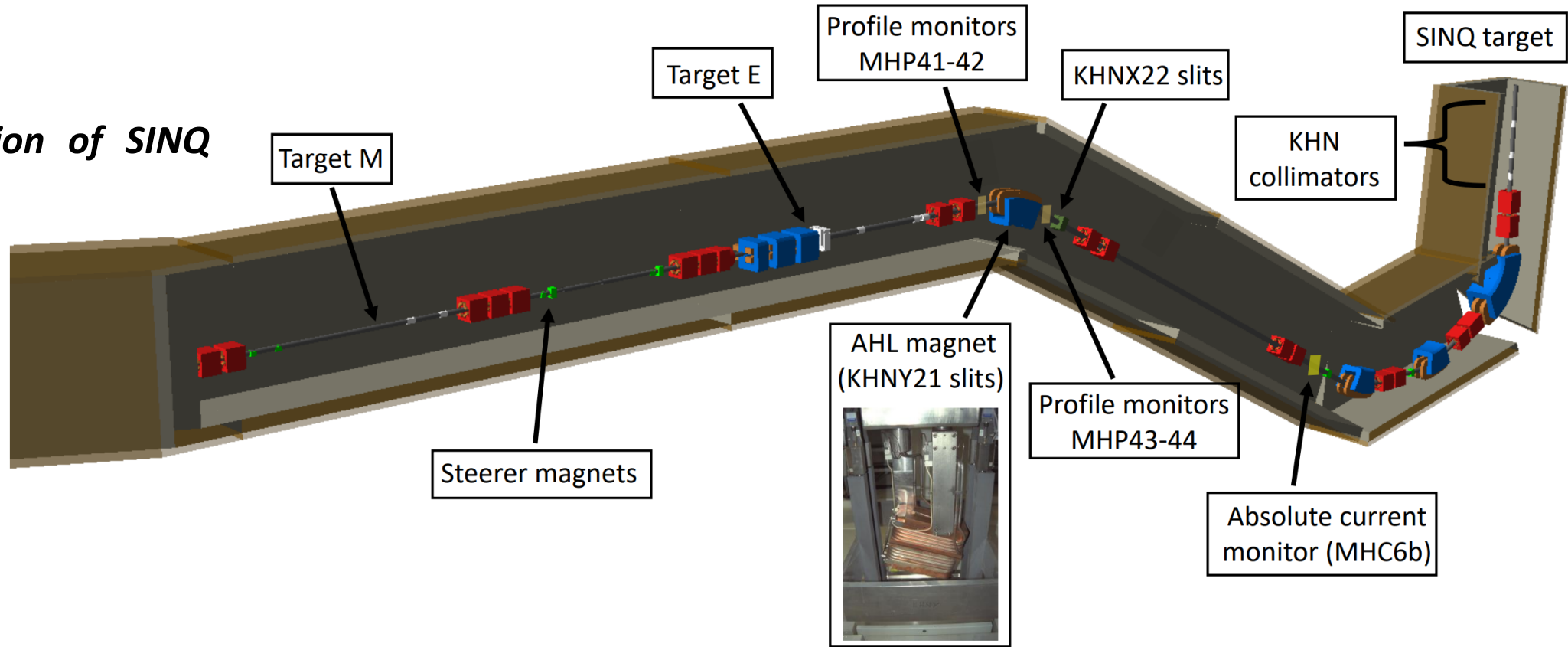

- Geometry of the tapered collimators and the target stations implemented by converting the step files (CAD model) into GDML files for BDSIM/Geant4 tracking (special thanks to D. Laube for providing the step files)
- Benchmarking with measurements. How to proceed?

Beam Delivery Simulation (BDSIM)

- Create 3D Geant4 model from optical description in minutes
 - Preliminary benchmarking with TRANSPORT and MAD-X
 - Pyg4ometry to convert CAD file into GDML tessellated solids
- Extensive particle physics models of Geant4
- MADX style input syntax in ASCII
- Can overlay geometry and fields for more detailed simulations
 - Particularly useful for the fringing field analysis at TgH
- Thick lens 1st order matrices used for in-vacuum tracking
- Simulate beam loss and beam interaction with matter in a particle accelerator
➔ **BDSIM shall be the reference code utilized for all our simulations**

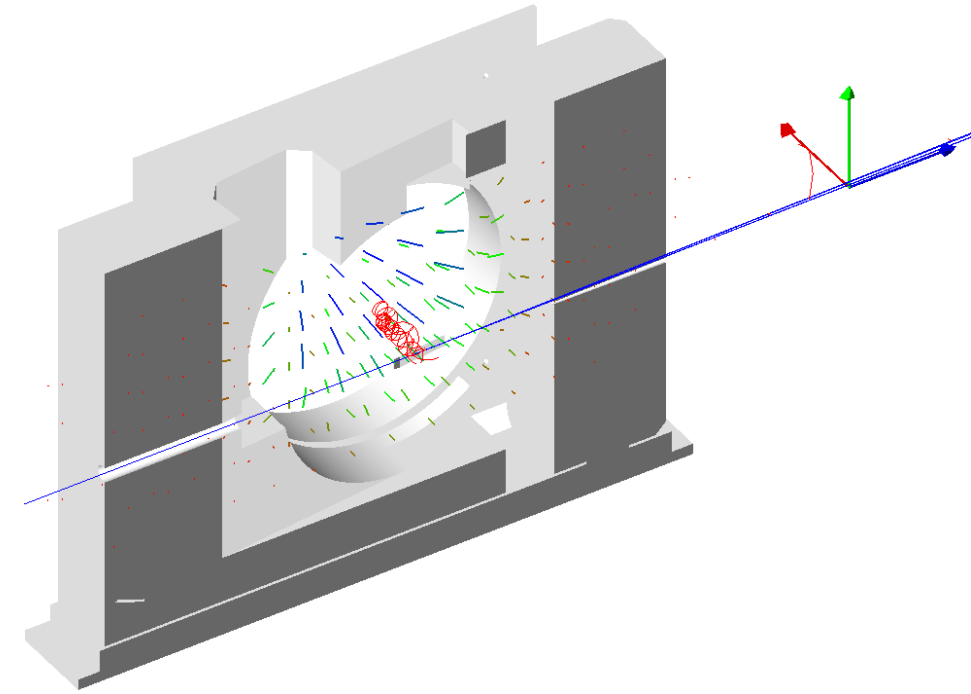

Side view of Tg M region with the field of the solenoids (cut by half for illustration purposes).

Benchmarking approach

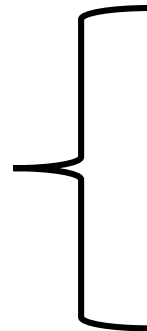
- 
1. Beam profile measurement → beam sizes, divergences and profiles
 2. Water temperature measurement → power deposition \equiv **localized beam losses**
 3. Beam current measurements → beam transmission \equiv **overall beam losses**

- Achieving agreement for a single current insufficient. Needs a parametric study for all measurements
→ the injected beam current from the cyclotron chain is a natural parameter!

Furthermore, the available surface temperature measurements enables us to explore and focus our analysis on the beamline parts exhibiting the largest losses

→ **Key starting point of the analysis..**

Probing the losses: approach

- Newton's law of cooling: $P = hA_s(T_s - T_\infty)$

A_s the heat transfer surface area

T_s the surface temperature of the object

T_∞ the temperature of the surrounding medium

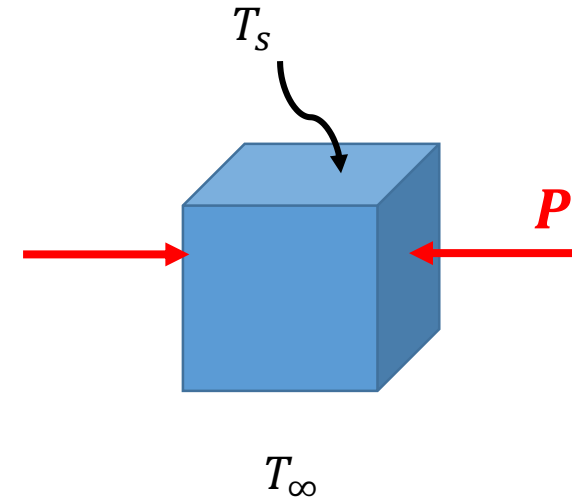

- Under nominal cooling conditions, and after reaching the steady heat transfer process, we define the relative excess power with respect to the linear behavior as follows:

$$\frac{\Delta P}{P} = \frac{\langle T_s \rangle - \langle T_{s,linear} \rangle}{\langle T_{s,linear} \rangle - \langle T_{s0} \rangle}$$

$\langle T_s \rangle$ the average surface temperature of the object

$\langle T_{s0} \rangle$ the average surface temperature at zero current

- An increase (resp. decrease) in $\Delta P/P$ shall be a synonym of increase (resp. decrease) in relative beam losses

Probing the losses: approach

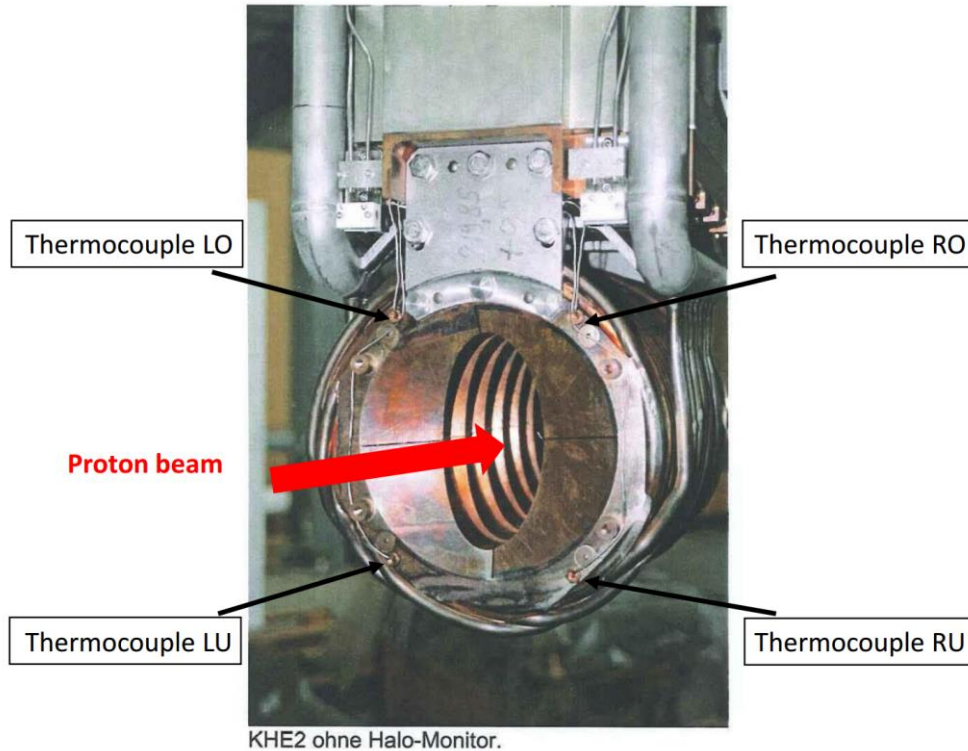

KHE2 collimator with its collimator teeth structure.

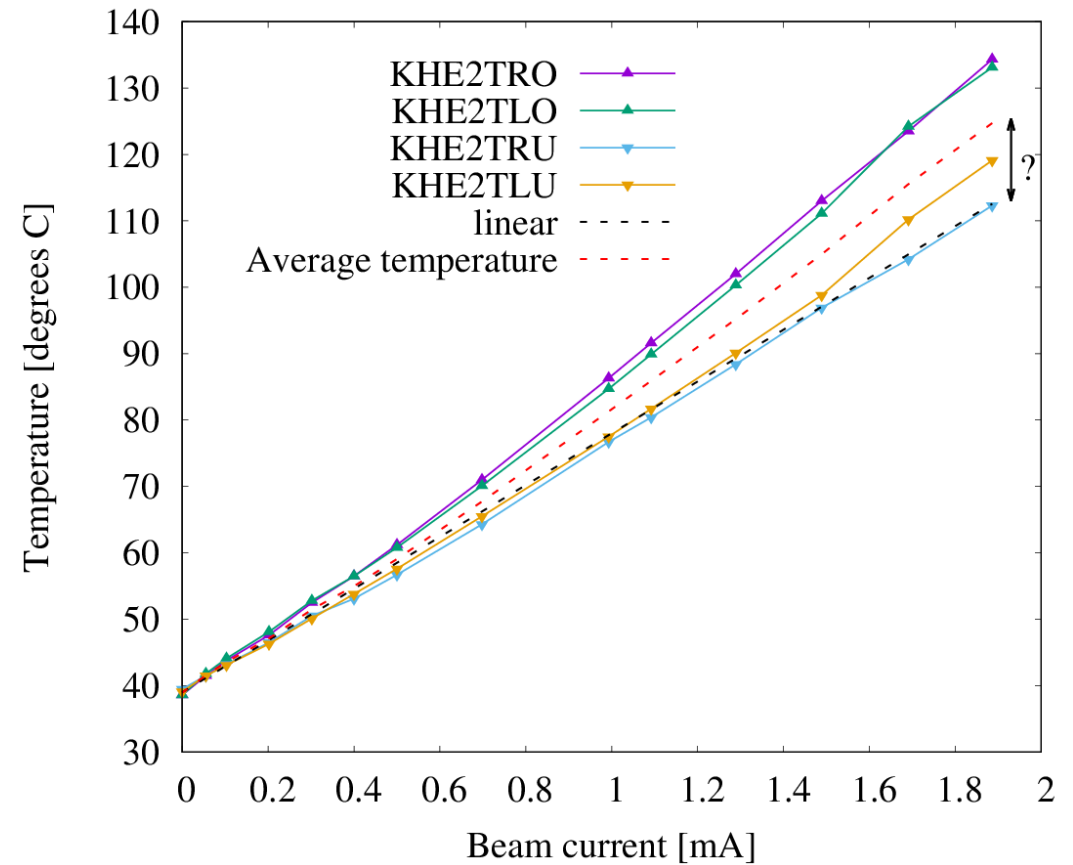

Measured surface temperature at the entrance of KHE2 collimator as a function of the injected beam current.

Key question: why the average temperature of KHE2 exhibits a non-linear behavior with the current?

Probing the losses: outcome

- All identified losses are controlled beam losses
- Uncertainty regarding the calibration of the thermocouple junction
→ Need for another approach to validate the histogram

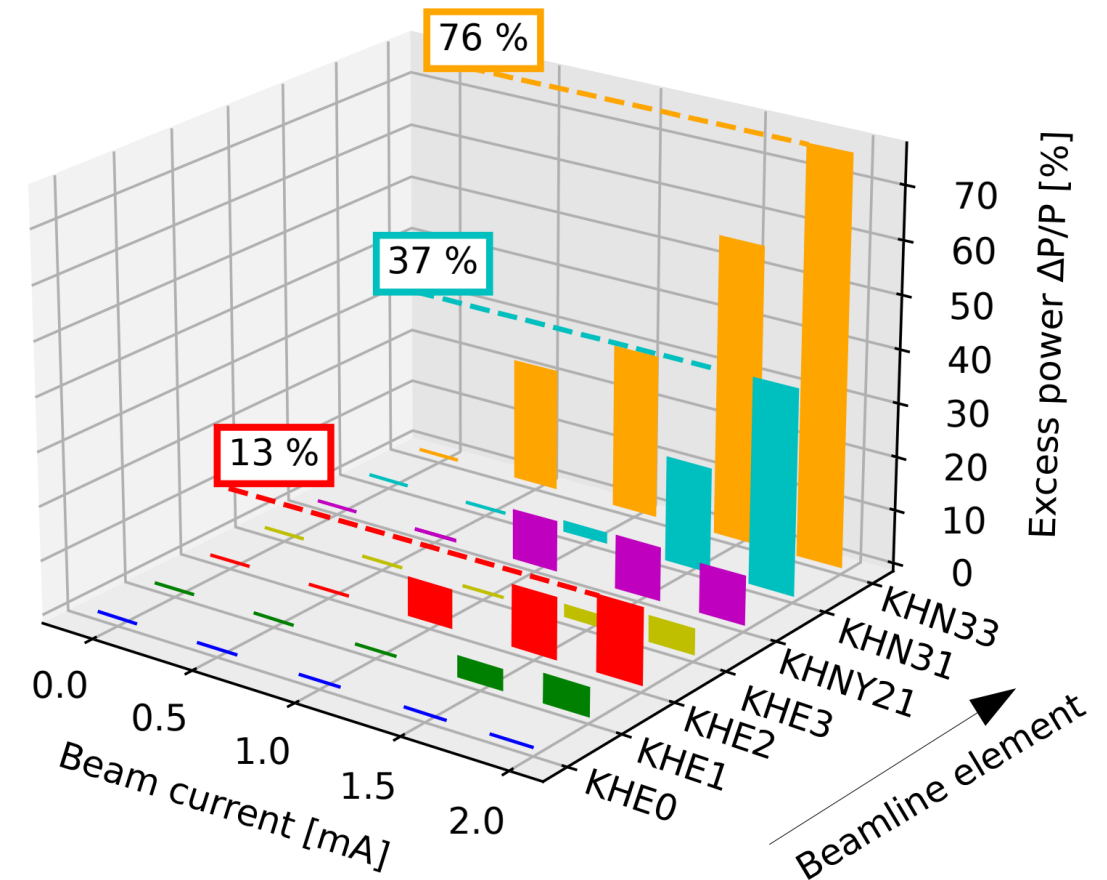

The histogram of distributed losses $\Delta P/P$ as a function of the beam current is shown for some of the most crucial elements.

- Identify the elements exhibiting important loss increase: TgE collimators and SINQ collimators
How to validate?

Benchmarking campaign

1. Beam profile measurement

- The initial beam conditions are obtained thanks to TRANSPORT (D. Reggiani)

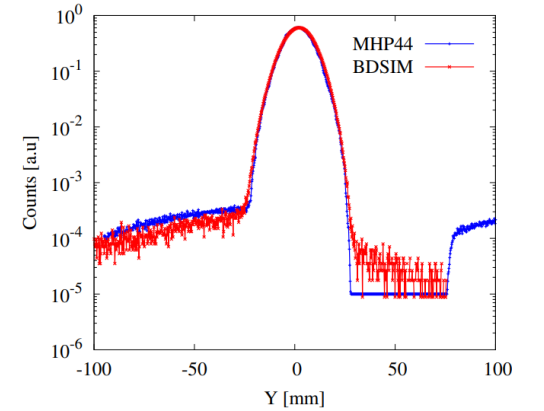
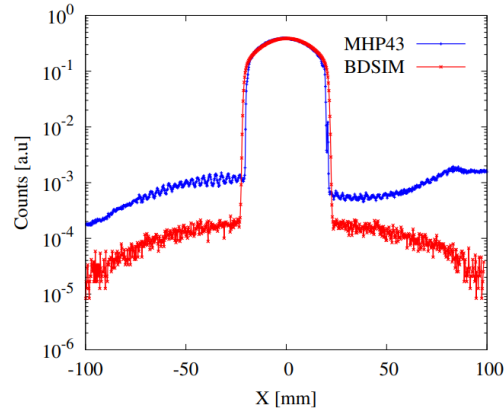
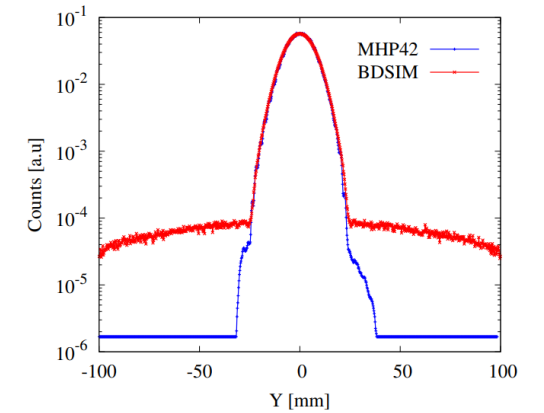
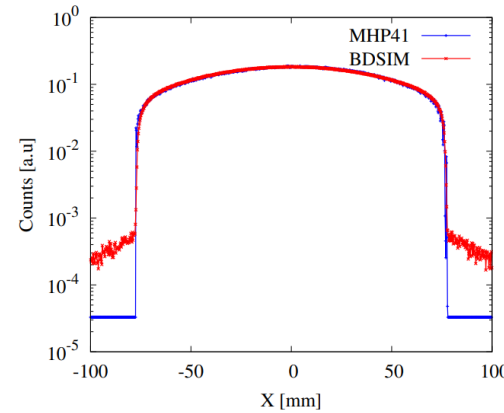
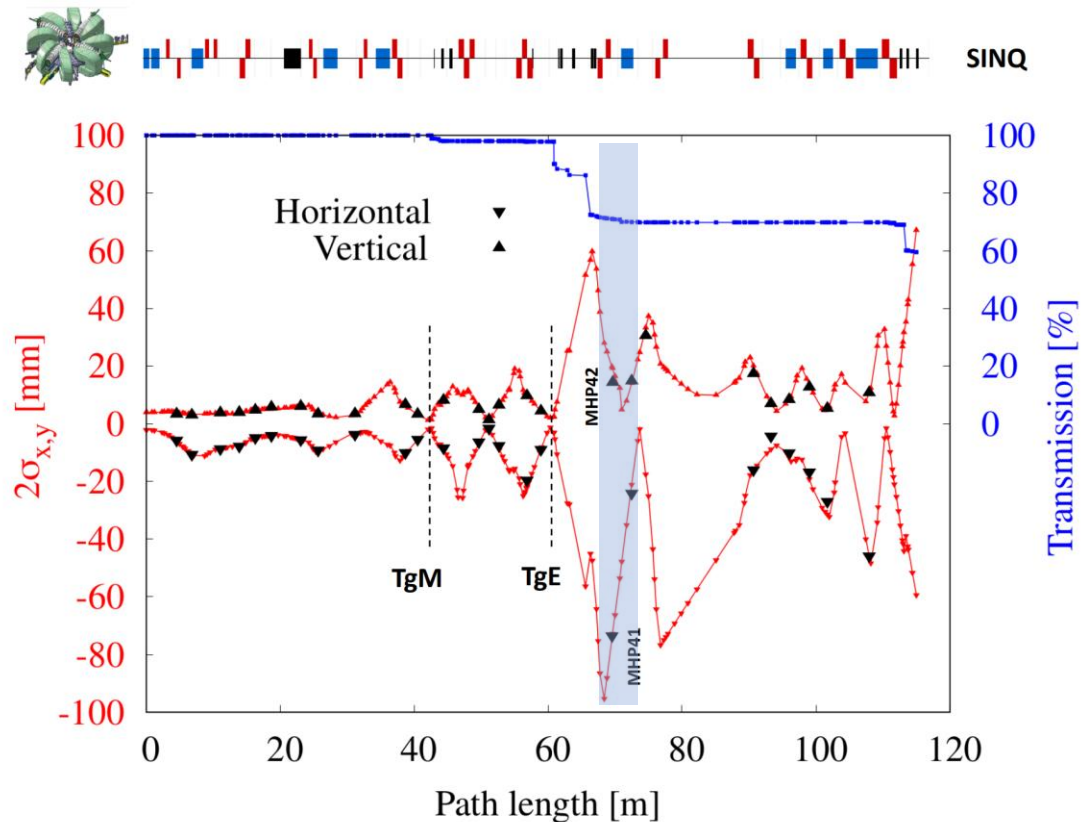

- Beam halo underrepresented at high currents
- What about the benchmarking for other beam currents?

Intensity-dependent beam conditions

- The beam is injected into the cyclotron chain by cutting through it with a movable collimator (KIP2)

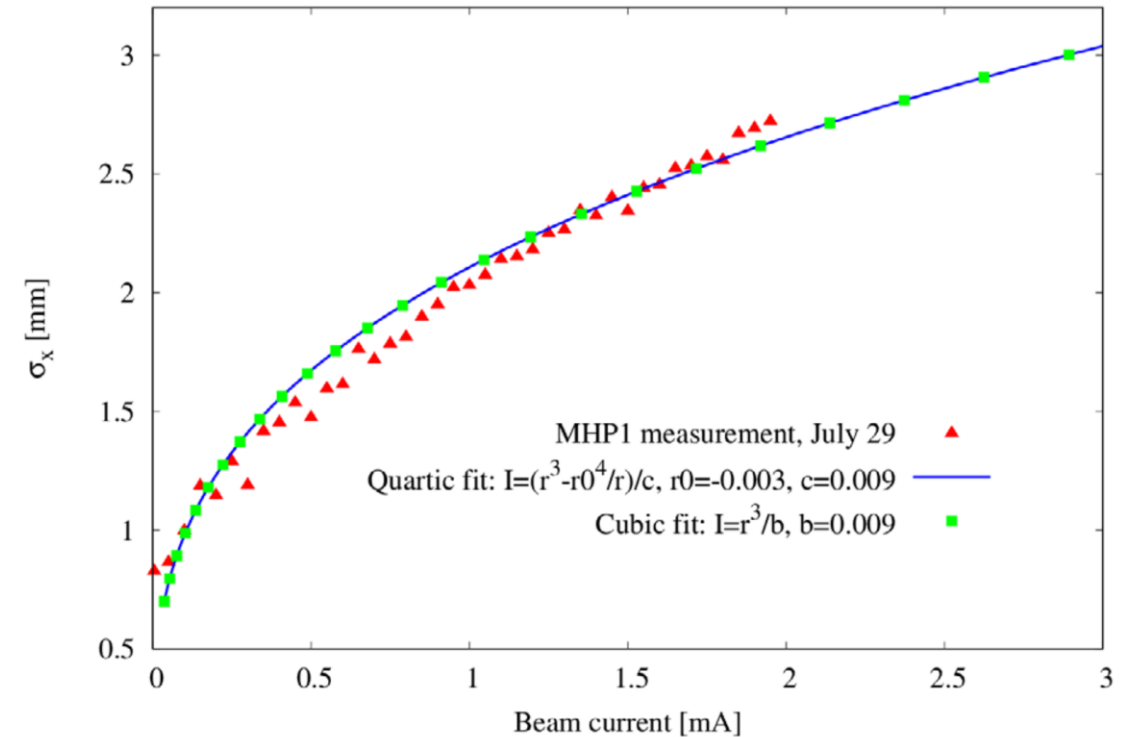
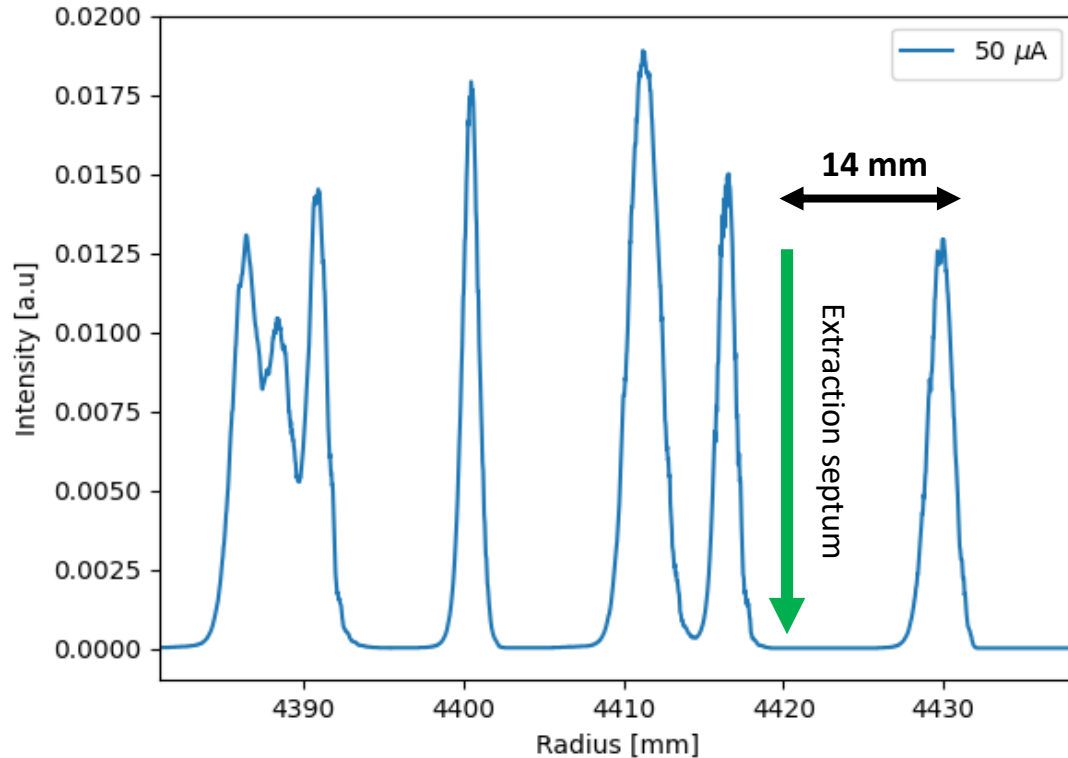

Radial probe measurement at the extraction of the PSI 590 MeV cyclotron: Normalized bunch intensity. Experiment in the frame of the HIMB project in June 2021.

2. Power deposition measurement 1/2

- For an actively-cooled element, the power deposition is: $P = \dot{m} c_p (T_{out} - T_{in})$

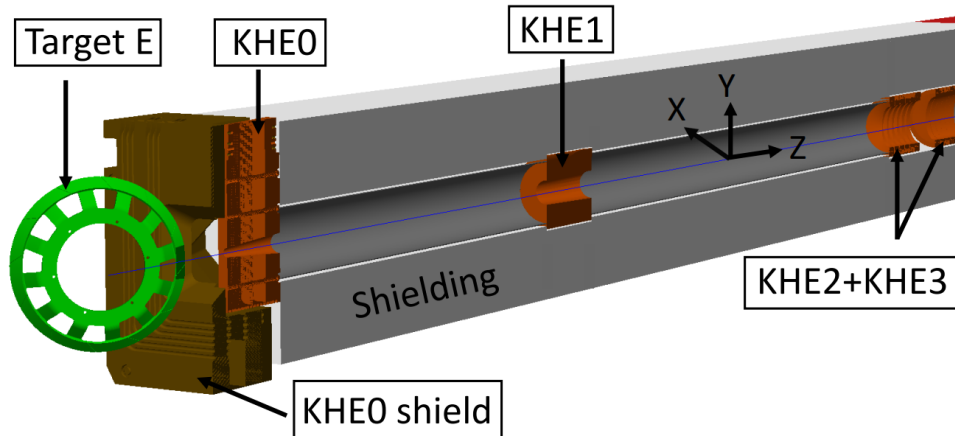

BDSIM model of the target E region

Target E collimators	Mass flow rate [kg/s]	Water temperature difference [K]	Power deposition measurement [kW]	Power deposition from simulations [kW]
KHE0	1.2	4.1 ± 0.1	20.7 ± 0.5	23.3
KHE0 shield	1.2	3.9 ± 0.1	19.7 ± 0.5	21.9
KHE1	1.2	3.0 ± 0.1	15.1 ± 0.5	15.3
KHE2	3.1	7.5 ± 0.1	98.1 ± 1.3	94.4
KHE3	2.7	1.8 ± 0.1	20.3 ± 1.3	19.1
Total	-	-	173.9 ± 4.1	174.0

Comparison of power deposition at 1.86 mA injected beam (MHC2b)

- Special thanks to J. Welte, C. Kramer and R. Zumsteg for providing information regarding the cooling circuit
- What about the benchmarking for other beam currents?**

2. Power deposition measurement 2/2

- For an actively-cooled element, the power deposition is: $P = \dot{m} c_p (T_{out} - T_{in})$

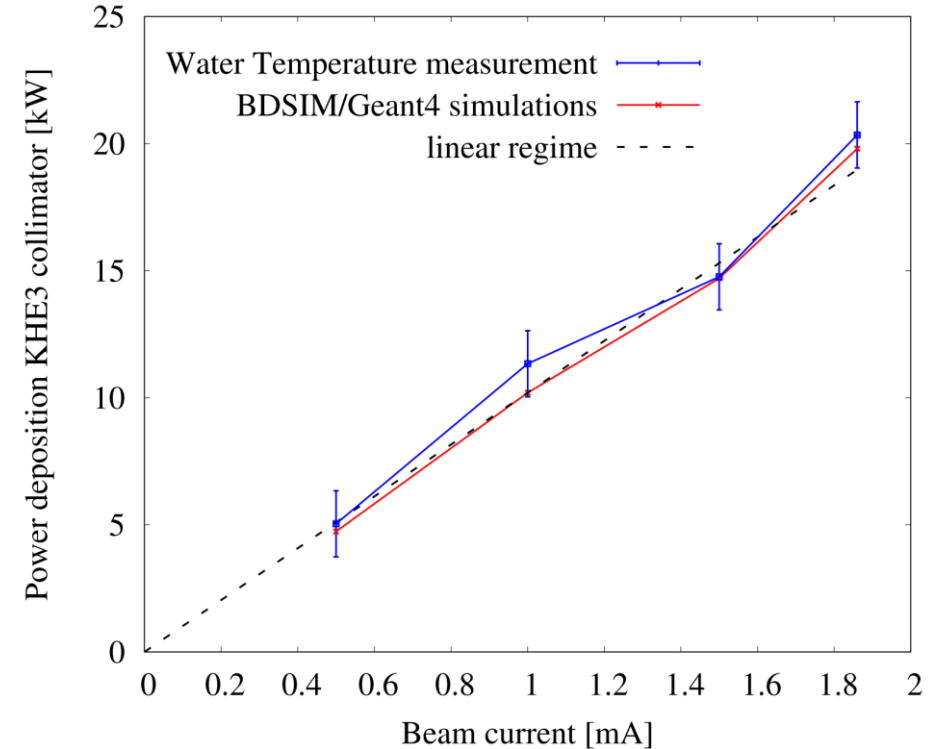
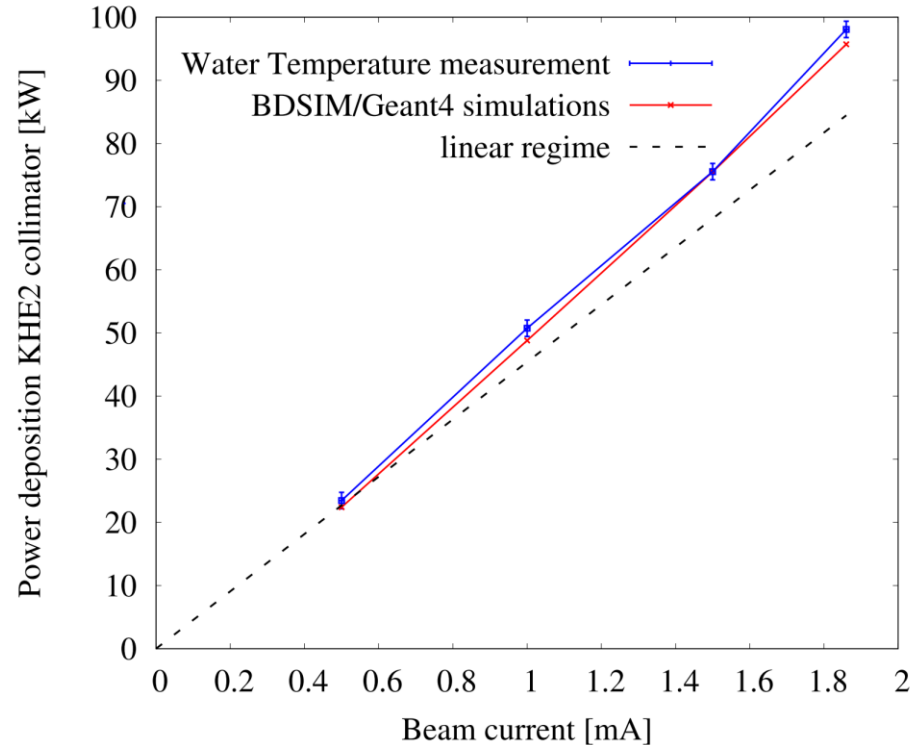

- Typically 20 min for each measurement to reach the steady state (~ 1 episode *Friends*).
- Excellent agreement with BDSIM simulations
- How to explain the departure from the linear regime at KHE2?**

3. Beam transmission measurement 1/2

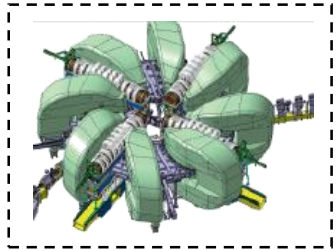

Absolute current monitor (MHC2b)

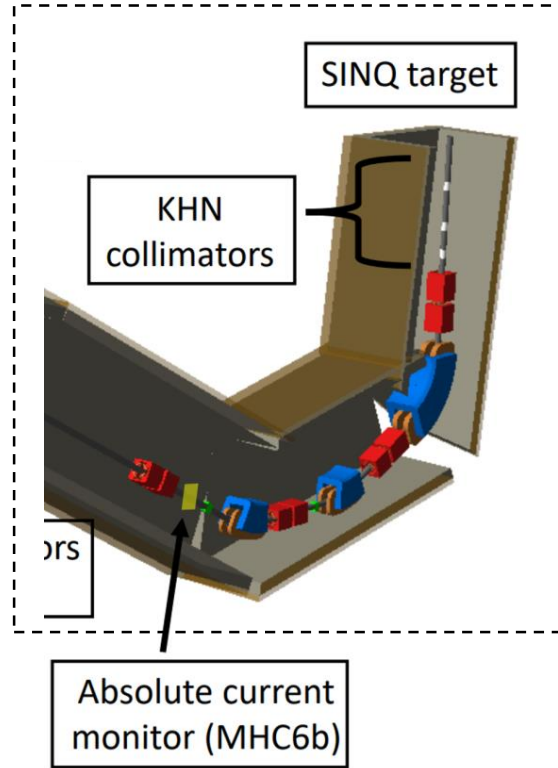

$$R = \frac{I_{MHC6b}}{I_{MHC2b}}$$

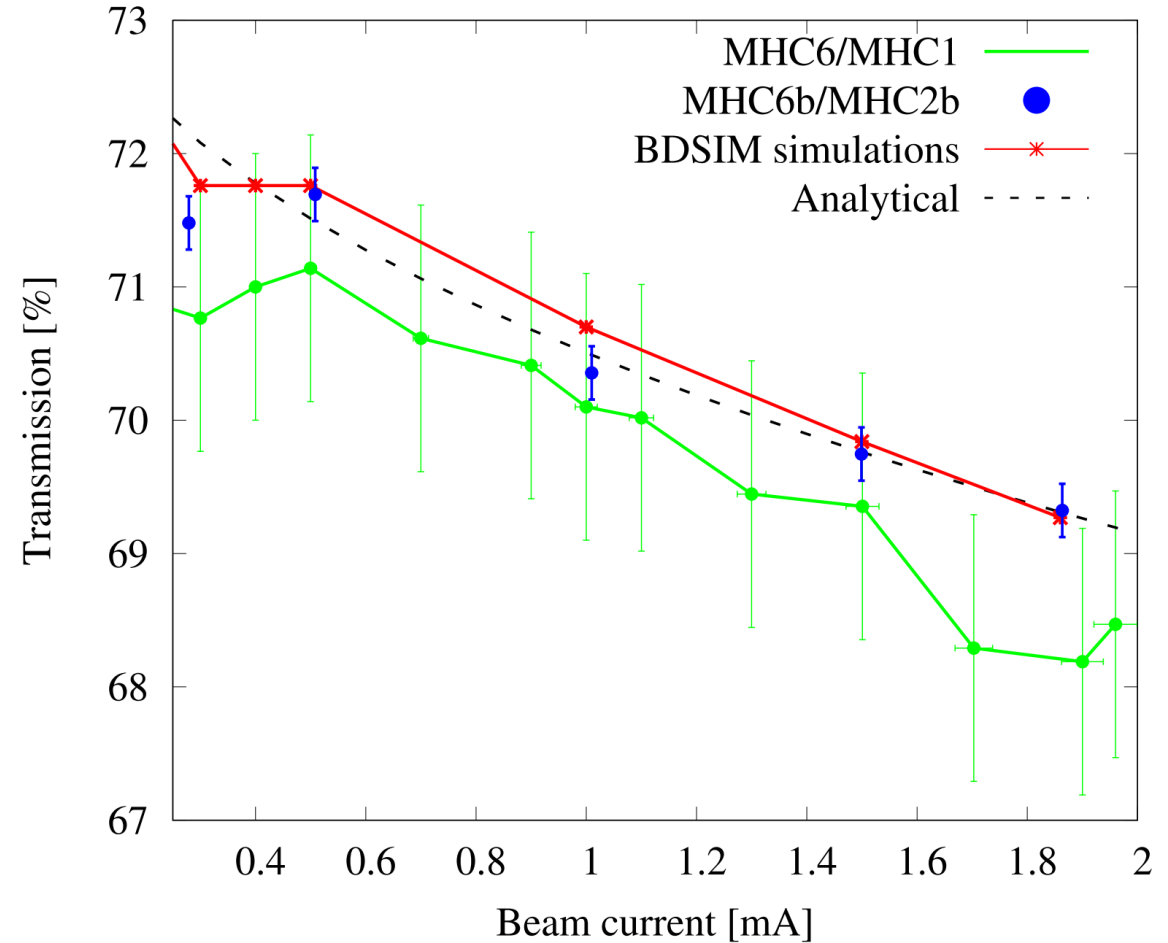

- Agreement between the measured and simulated transmissions at the 0.4% level for all currents
- **How to explain the transmission drop with increased beam currents?**

3. Beam transmission measurement 1/2

- Treating KHE2 and KHE3 collimators as a single block, it can be shown that:

$$p_{\text{KHE23}} = \frac{I_{\text{KHE23}^-} - I_{\text{KHE23}^+}}{I_{\text{KHE23}^-}}$$

$$= \text{erfc} \left(\frac{a_x}{\sqrt{2} \left[\sigma_{x0}^2 + L \left(\sigma_{x0}'^2 + \vartheta_{sc}^2 \right)^{1/2} \right]} \right)$$

ϑ_{sc} is the rms scattering angle of the target

- Increased beam current from the cyclotron
 - Increased beam divergence at TgE
 - Increased losses on the subsequent collimators (KHE2)
 - Dropping transmission at MHC6b

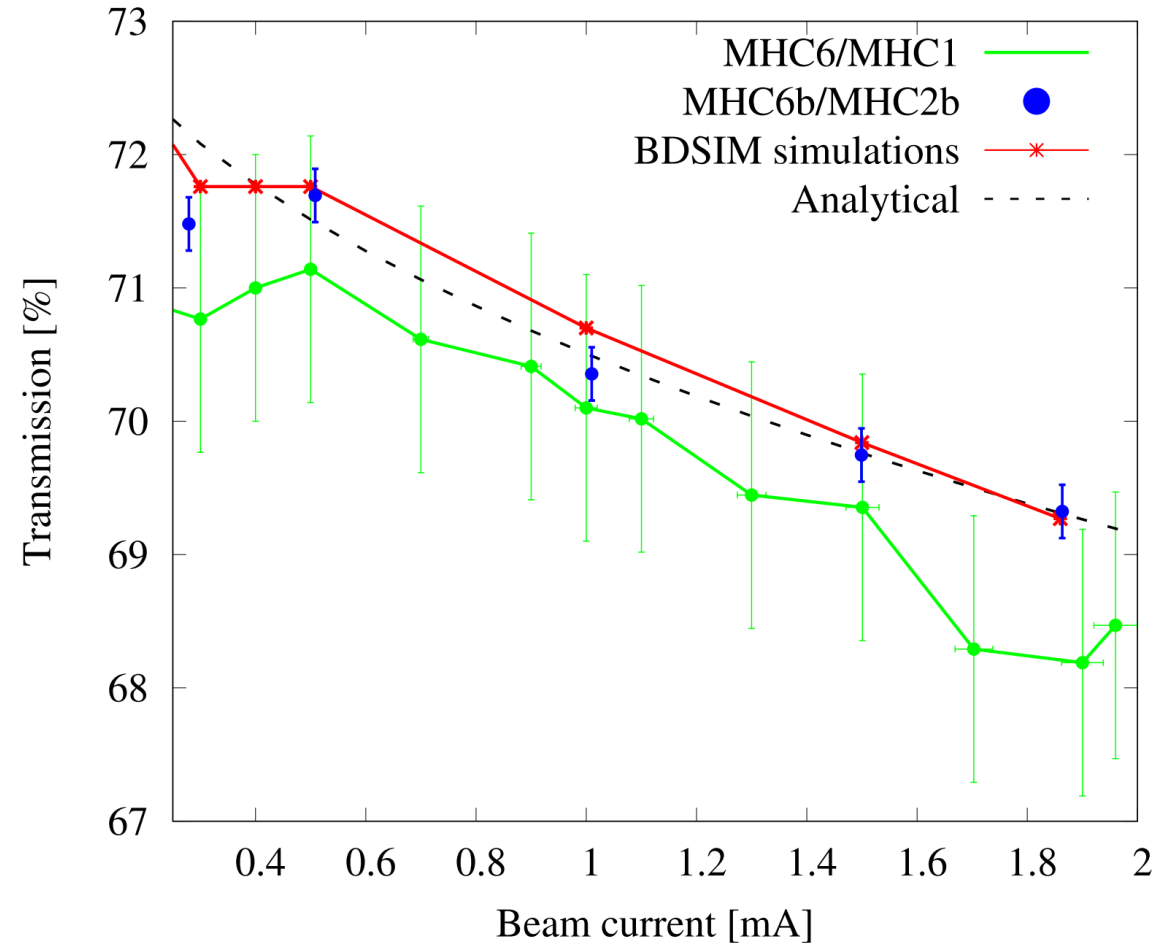

- The impinging beam divergence at the target is the single most important beam parameter to explain the subsequent losses

3. Beam transmission measurement 2/2

- Combining water temperature and surface temperature measurements
 → beam-based determination of the effective heat transfer coefficient for KHN collimators

- Validated at different beam currents

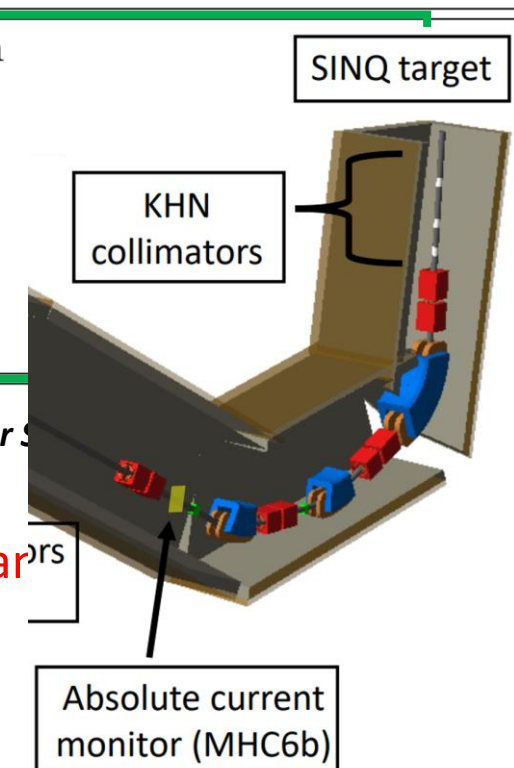
Beam current [mA] at MHC2b	P_{KHN} [kW] from water temperature	SINQ target	IC_{6b} [%]	R_{SINQ} [%]
0.5	7.2		± 0.2	67.4 ± 0.9
1.0	19.8		± 0.2	64.5 ± 1.2
1.5	32.0		± 0.2	63.3 ± 1.3
1.86	44.7		± 0.2	62.1 ± 1.4

Power deposition measurements for SINQ target

Beam transmission measurements

- Taking into account the losses at SINQ collimators, a corrected beam transmission is deduced

- Given the need to protect the spallation target against overfocused beam, losses can occur at the very last stage of its delivery

Implications for HIMB (High Intensity Muon Beamline)

New layout

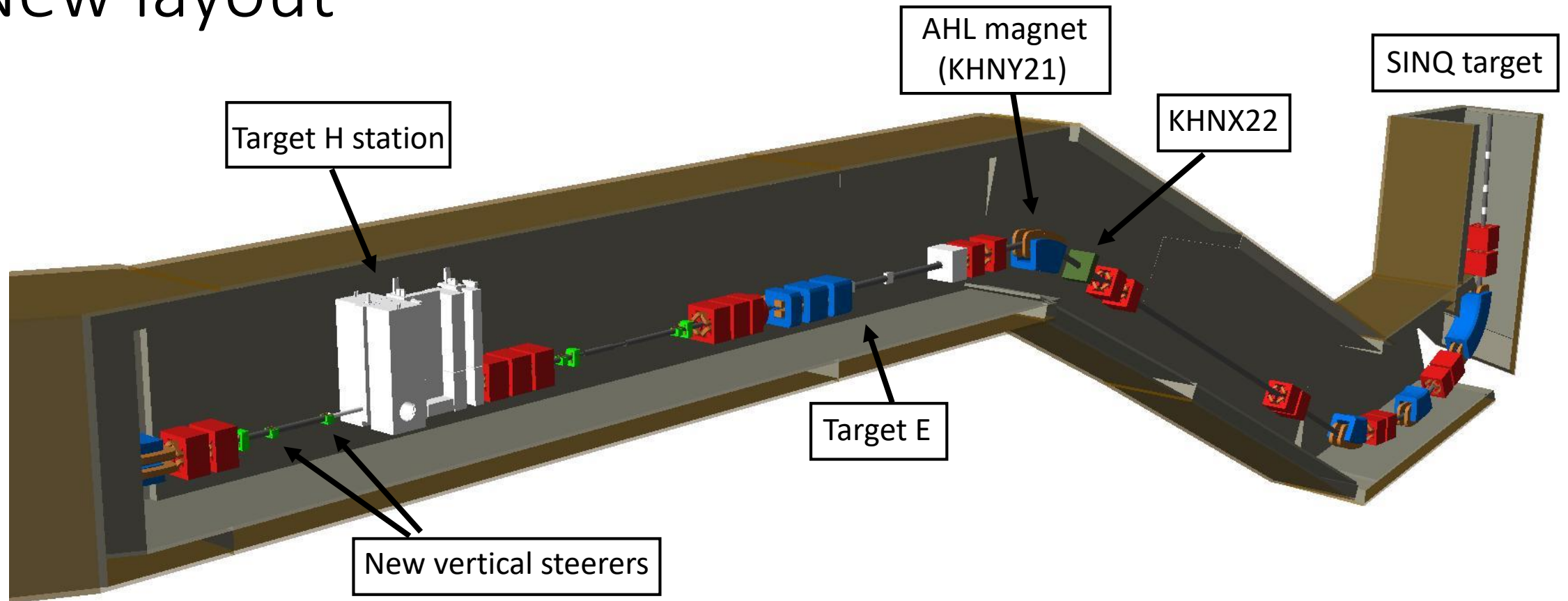

- New layout of TgH station: Replacing target M (5mm) with slanted target H (20mm) to increase surface muon production
- Addition of two new vertical steerers for fringing field correction

Major changes to proton beamline

- Changing beam properties after striking the 20mm Target H:
 - **Beam energy loss: 8.45 MeV** after impacting TgH (2 MeV with existing TgM)
 - bending fields to be lowered accordingly
 - **Beam fraction reaching TgE 5% lower with TH** → low energy positions on TgE and its collimators
 - **Beam properties** (emittance, halo) after TgH → optics adjustment needed
- Larger Power Deposition on TgH and TgE, and after AHL dipole
- Fringe field of quadrupole lensoid kicks the beam vertically: Correction needed
- Collimator system downstream of TgH redesigned
- Dose maps for crucial elements calculated for subsequent thermal analysis

Main constraints: → lowest losses
Highest transmission to SINQ + lowest losses

New beamline layout at TgH region

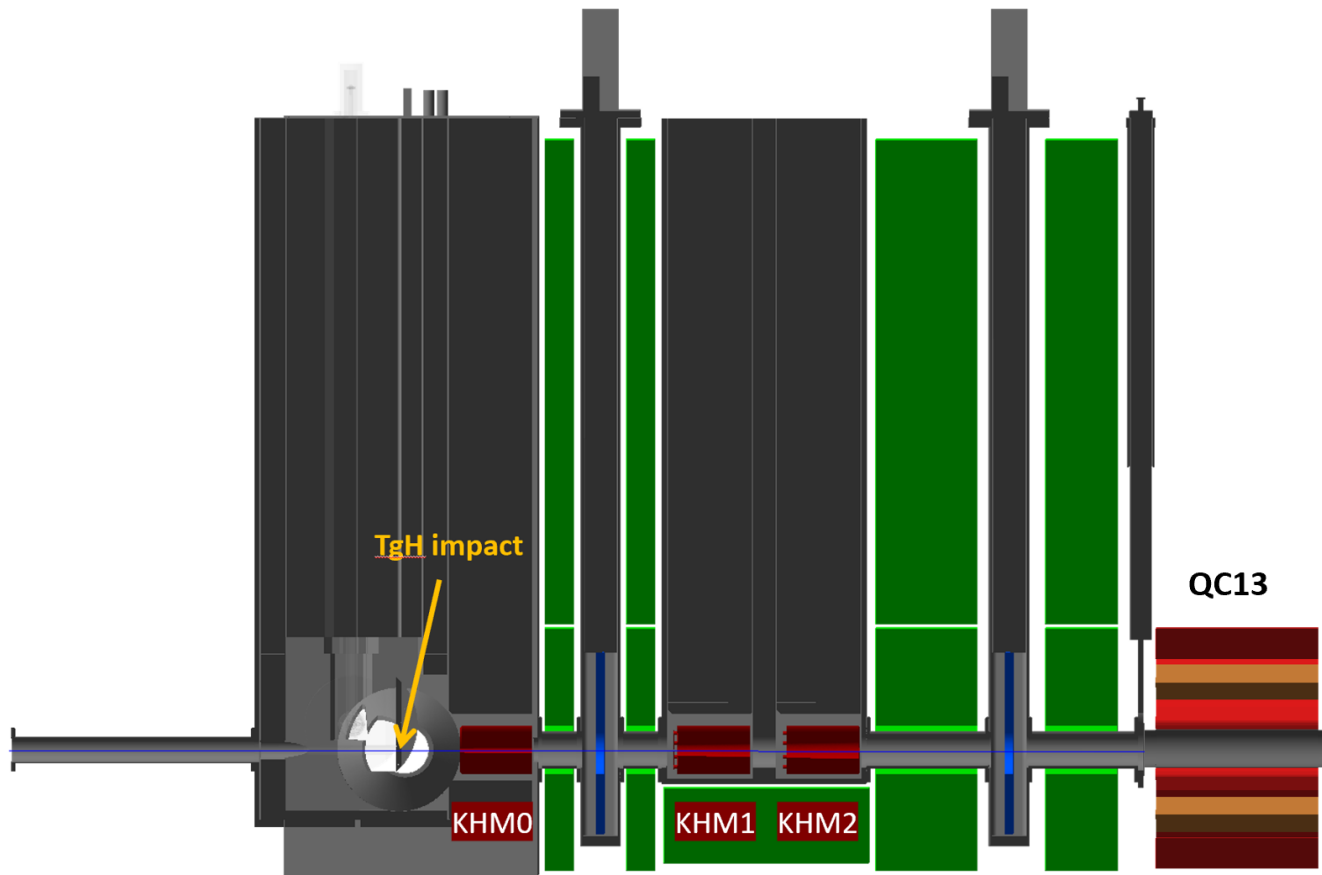

MCNP6 results provided by V. Talanov

Beamline Element	BDSIM (kW)	MCNP6 (kW)
Target H	17.9	18.7
KHM0	22.9	20.3
KHM1	7.8	8.8
KHM2	0.9	1.3
Total	49.5	49.1

- New collimators (in red) designed to withstand the larger power deposition due to:
1) thicker target 2) higher beam current (3 mA upgrade). Two profile monitors (in blue)
- **Added shielding (in green) particularly important to properly assess the deposited power**

Collimators design

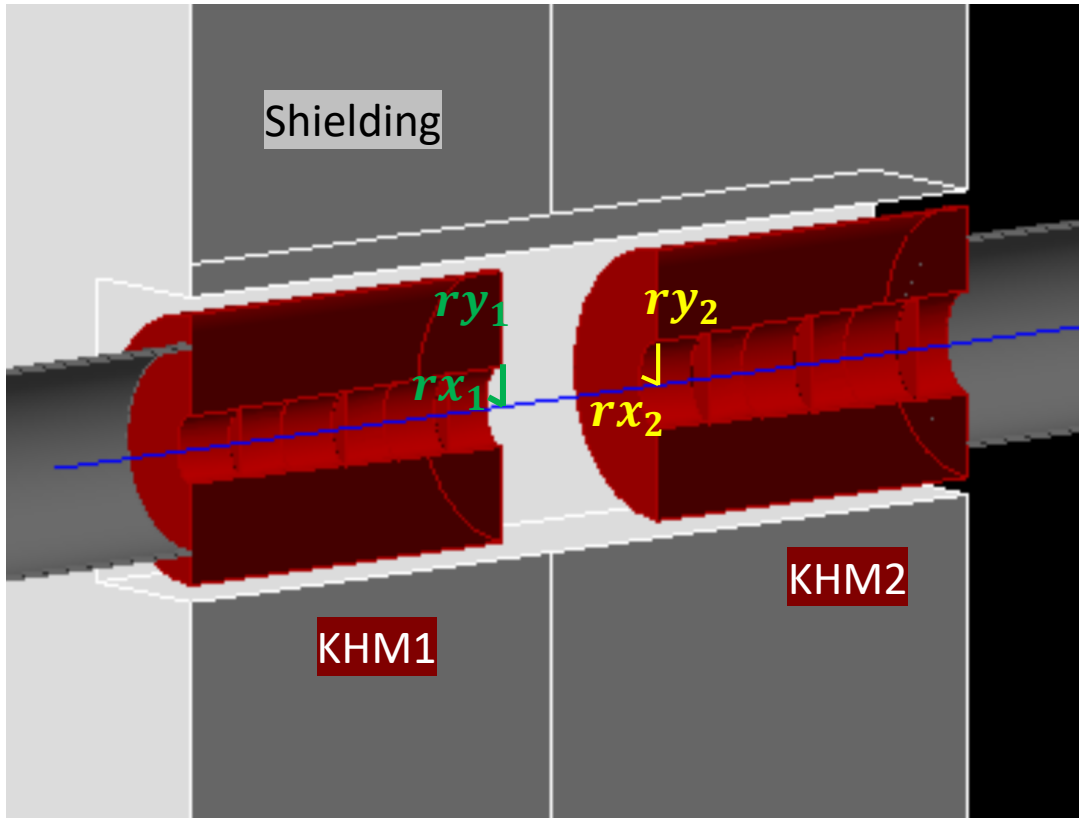

- Elliptical cross section for KHM1 and KHM2 collimators such as the horizontal aperture is smaller than the vertical one
- The aim is to protect triplet 1 where the horizontal beam size is larger than the vertical one.

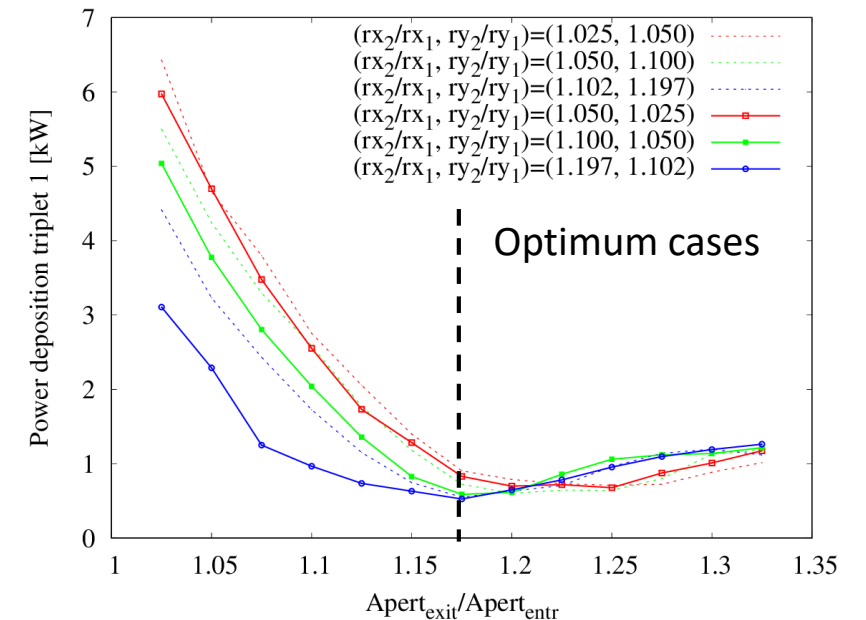
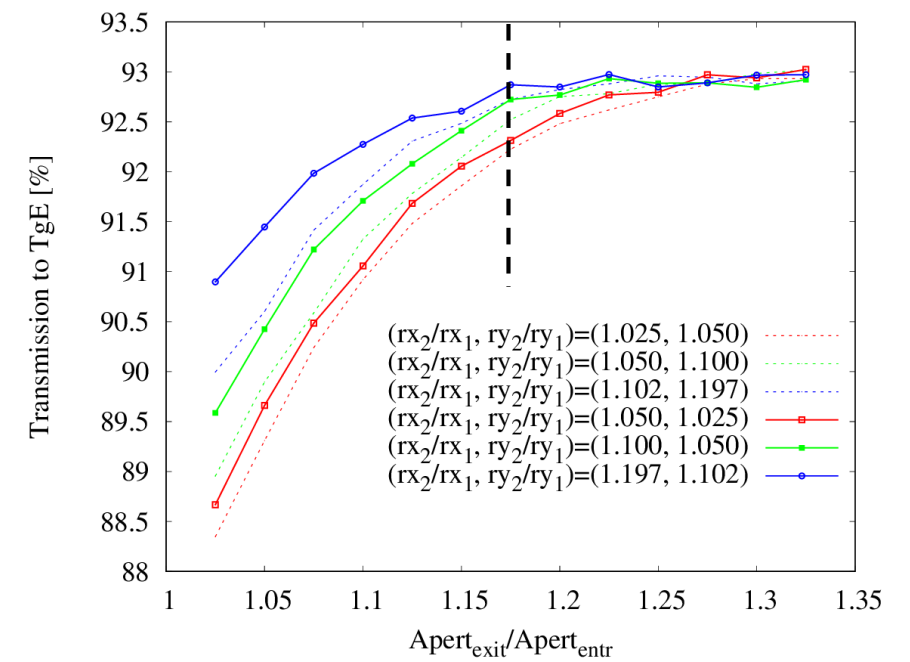

Fringing field of the capture solenoid

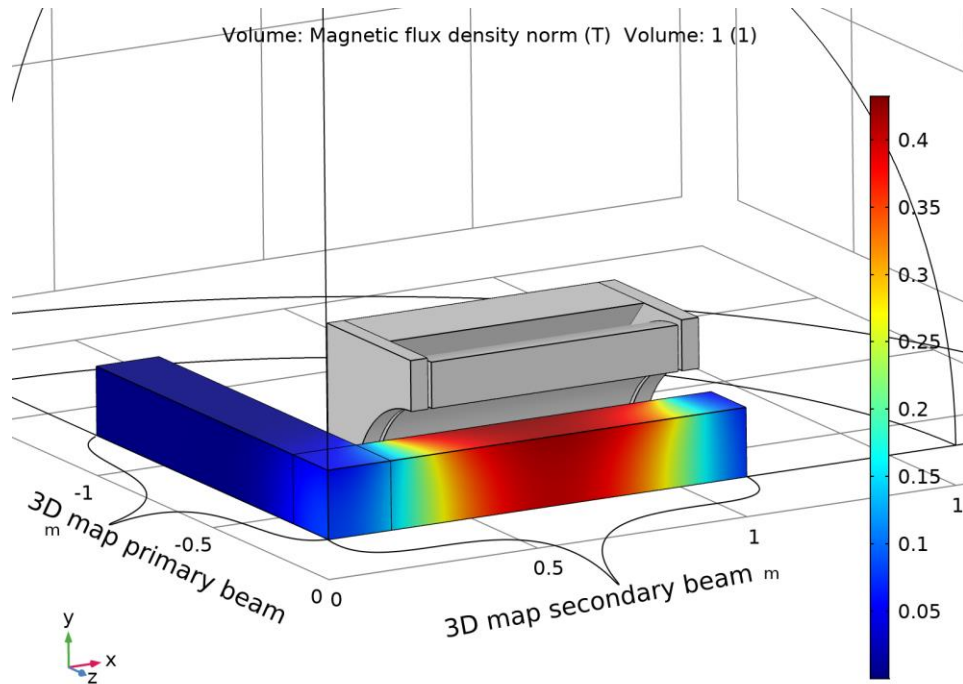

Fringing field due to the capture solenoids (mirrored symmetries around xy, yz and zx planes), courtesy S. Hellmann

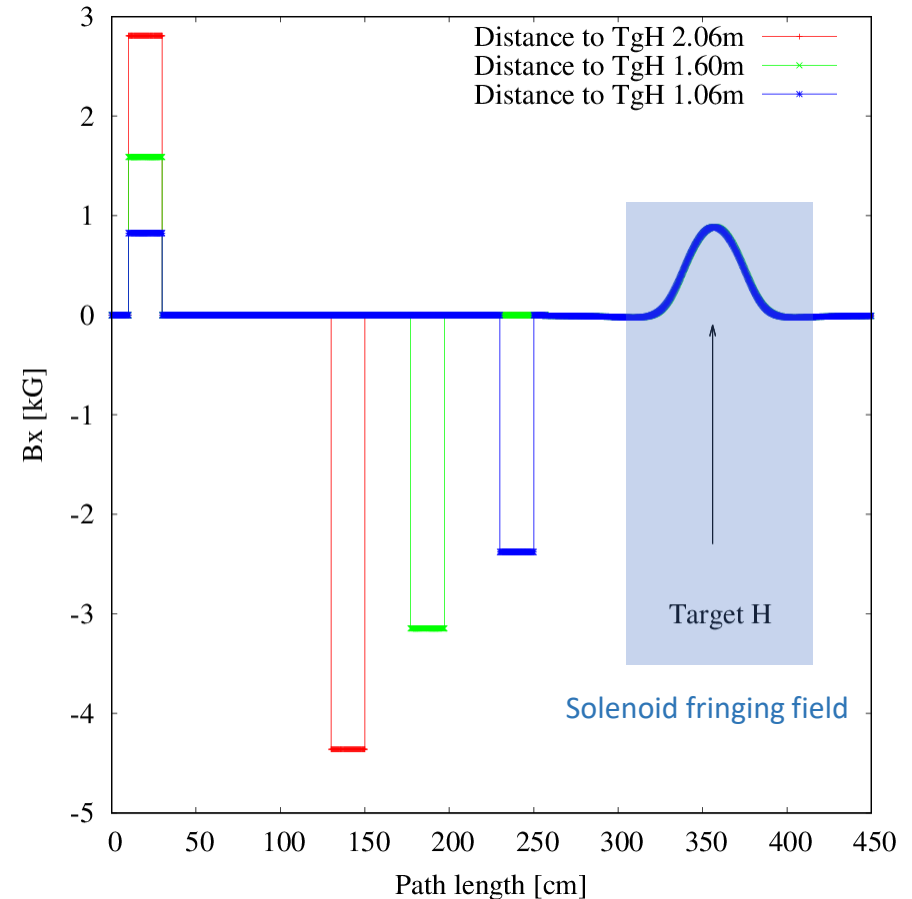

Fringing field correction by means of two horizontal steerers

- Only the horizontal magnetic field component B_x is seen by the primary proton beam. Correction by means of two vertical steerers. Position and strength not yet frozen

Beam envelopes, TgM5mm vs TgH20mm

- Beam envelopes from the ring cyclotron to SINQ target and comparison with measurement for the standard TgM 5 mm
- Optics tweaked in TgM-TgE region to minimize primary beam losses at the location of the limiting apertures, namely K18 and QC13
- Energy spread after TgE about a factor of 2 larger for HIMB
→ differences after AHL dipole
- Optics tweaked by $\pm 3\%$ after TgE
- Increase the opening of KHNY21 slits by 2 mm

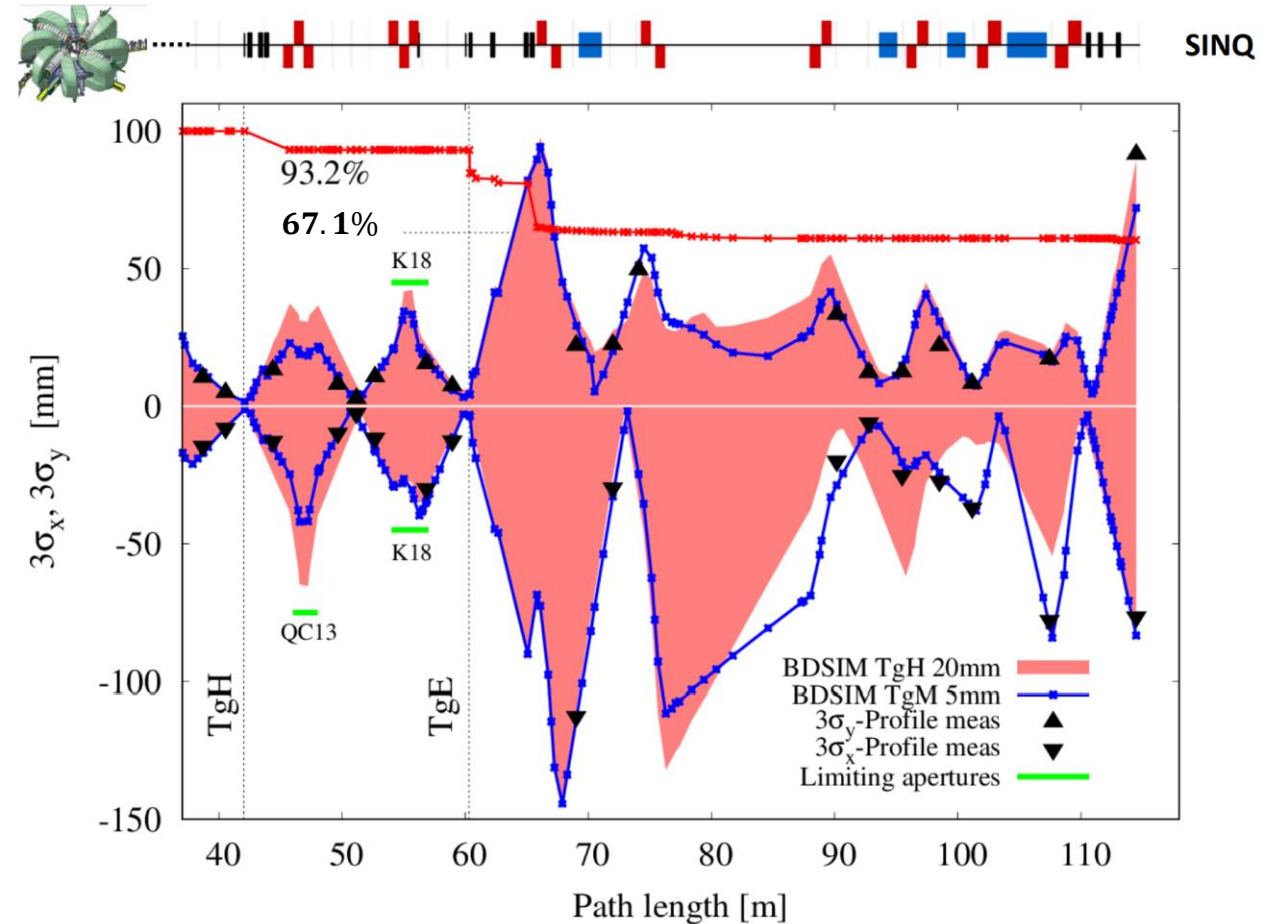

Target E – SINQ: Energy depositions chart

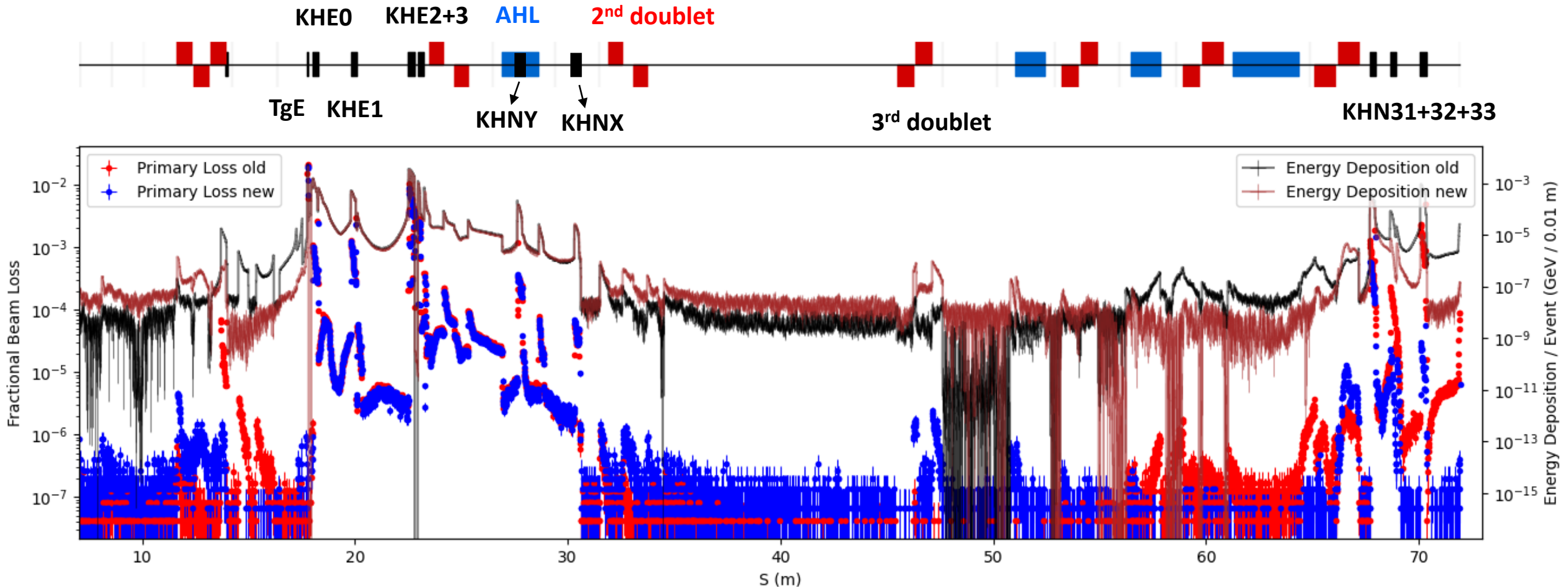

Energy deposition and beam losses chart at the SINQ beamline.

- **The optics between TgH and TgE is optimized to**
 - 1) reduce the impinging beam divergence on TgE
 - 2) ensure ~no beam misses TgE

Target E – SINQ: Energy depositions chart

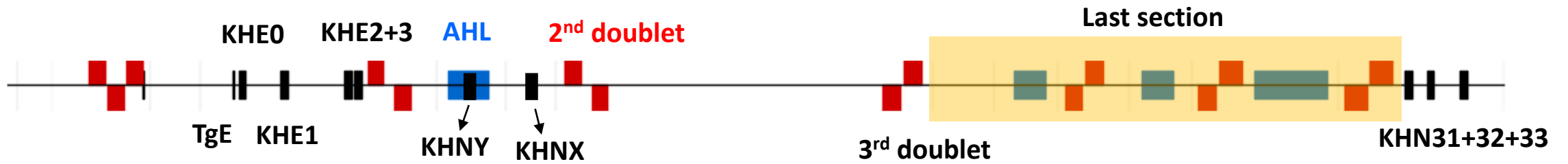

Element	Primary beam losses [%]	Energy depositions [kW]
Target E	8.2	41.7
KHE0	1.68	20.97
KHE1	1.90	17.64
KHE2	11.03	106.78
KHE3	3.06	19.24
1 st doublet QG21-22	0.93	7.98
1 st bend AHL	0.73	6.04 (5.11 to KHENY-8mm)
KHNX slits	0.088	0.76
2 nd doublet QG23-24	0.00065	0.0077
Last section	0.04	0.44

Power depositions with Target M @ 2mA

Element	Primary beam losses [%]	Energy depositions [kW]
Target E	7.7	39.22
KHE0	1.53	20.00
KHE1	1.74	16.03
KHE2	9.60	92.59
KHE3	2.64	16.21
1 st doublet QG21-22	0.84	7.28
1 st bend AHL	0.65	5.39 (5.01 to KHENY-10mm)
KHNX slits	0.096	0.85
2 nd doublet QG23-24	0.0050	0.047
Last section	0.05	0.52

Power depositions with Target H @ 2mA

New collimators for 3 mA upgrade

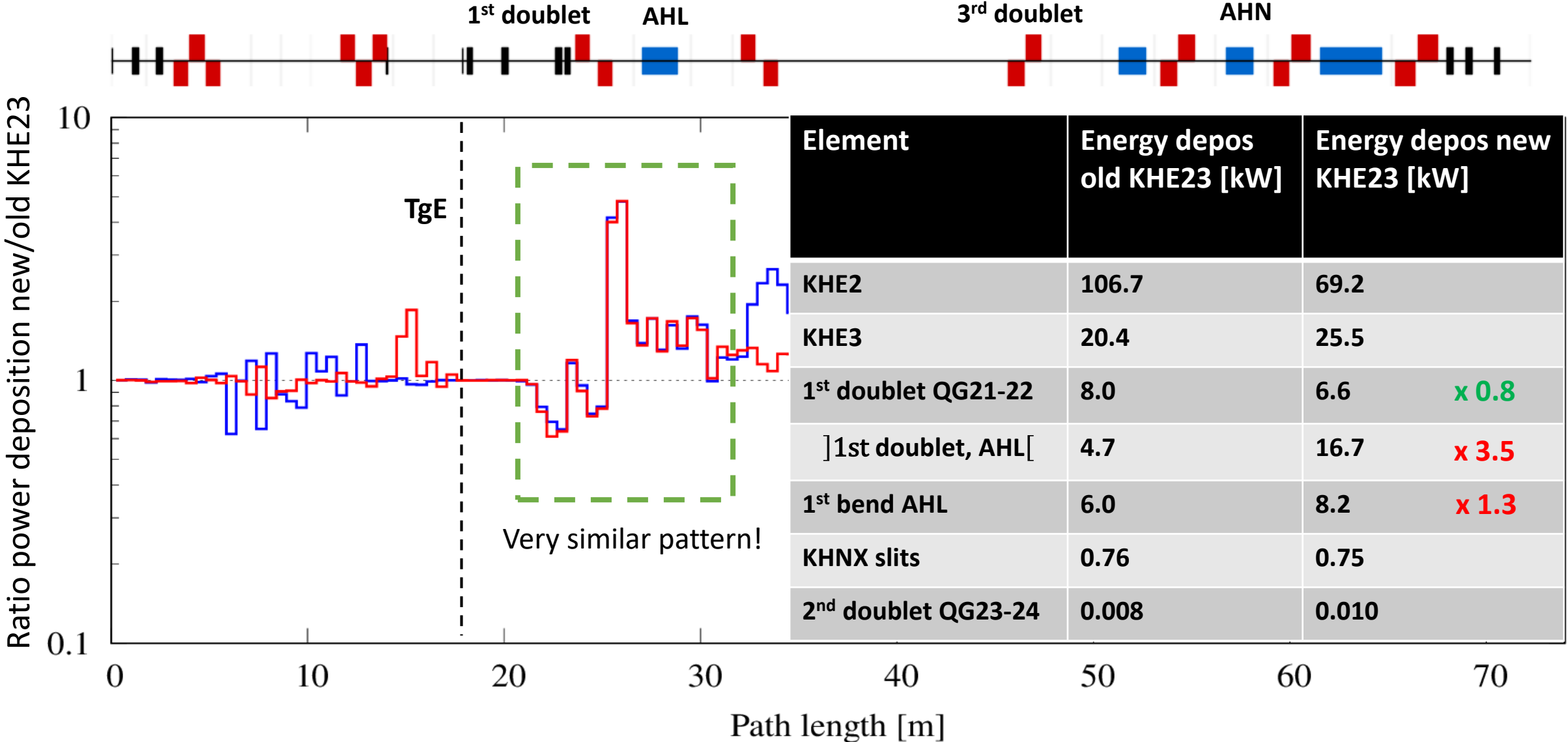

- Changes to the beam losses almost the same with TgH or TgM up to the 2nd doublet

HIMB transmission

- With the current TgE collimators, replacing TgM with TgH shall decrease the transmission to SINQ by 2% only
- With HIMB, flat beam transmission to SINQ (i.e., almost independent of the injected current)

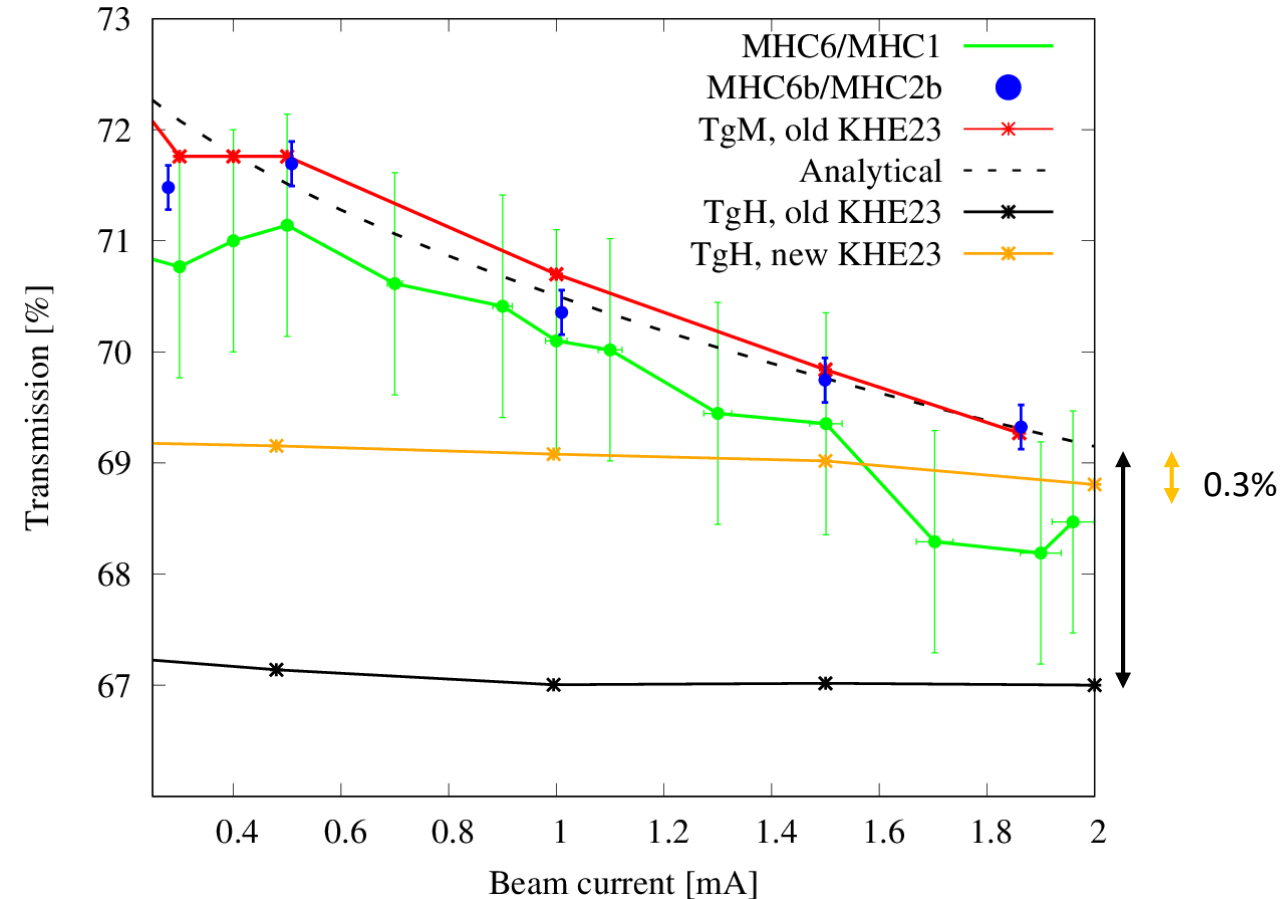

- Replacing TgE collimators with the newly designed ones, and replacing TgM with TgH shall enable the same beam transmission to SINQ

Conclusion

- We are confident that our modeling of the HIPA upgrade project, HIMB is reliable
- In order to break into the precision level of the absolute current monitors (0.2%), the approach based on the surface and water temperature measurements shall be generalized to other beamline elements
- Implementation of the beam loss monitors could be undertaken in the model to further improve the understanding of the losses
- Beam-based determination of the effective heat transfer over the years to predict the aging effect on the actively-cooled components (such as collimators)
- Next, freeze the design of the solenoid magnet for HIMB to determine the positioning and strength of the corrector magnets

The Benchmarking dilemma

“No one believes in simulation results except the one who performed the calculation, and everyone believes the experimental results except the one who performed the experiment.”

Martin Greenwald, MIT, 2004

Special thanks to: **D. Kiselev, D. Reggiani, J. Snuverink, D. Laube, A. Knecht**

C. Baumgarten, H. Zhang, P.-A. Duperrex, R. Dolling, R. Sobbia and J. Kohlbrecher

L. Nevay and S.T. Boogert for helping with BDSIM and Pyg4ometry

Backup slides

Beam profile measurement

Beam current 1.9 mA

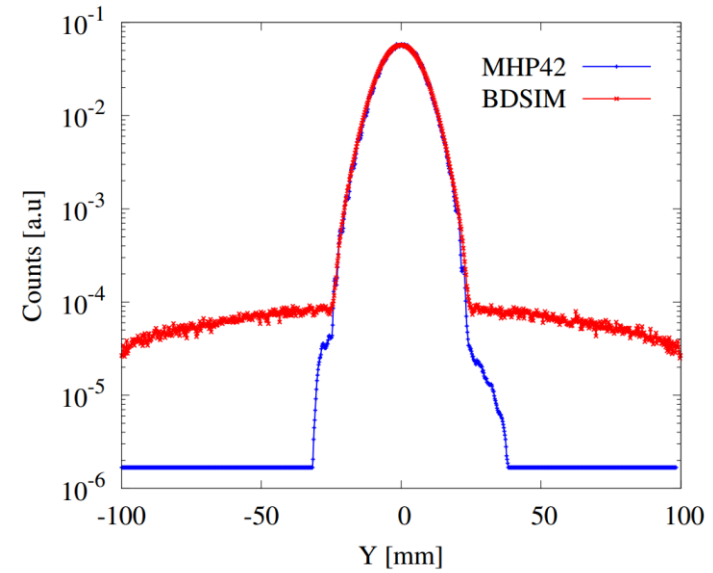
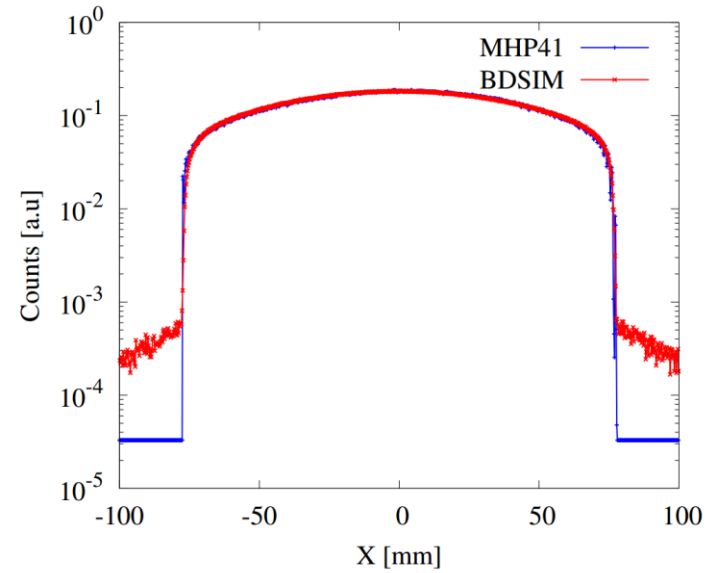

Beam current 0.1 mA

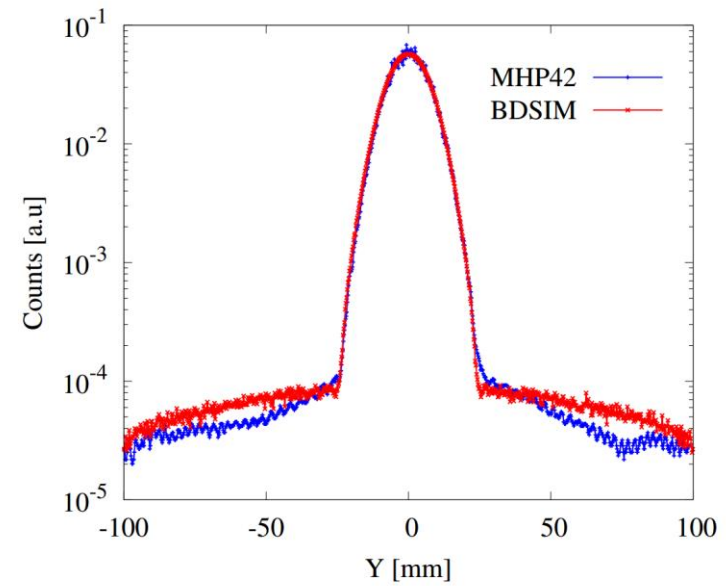
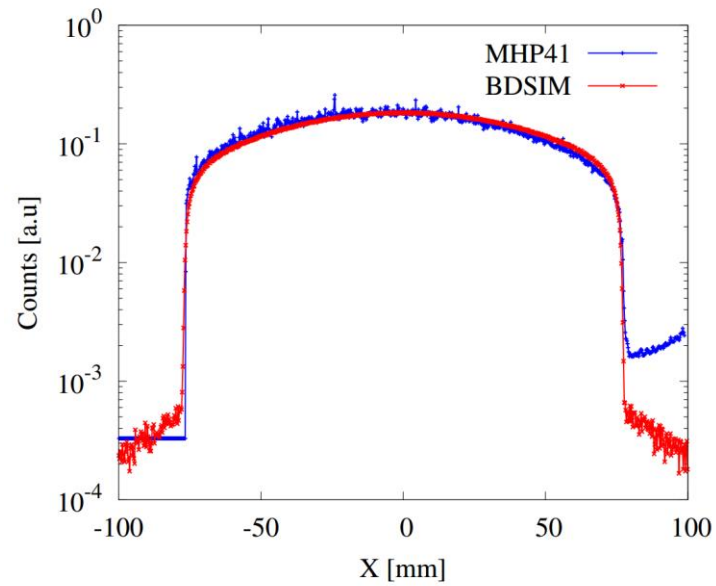

Beam divergence measurement

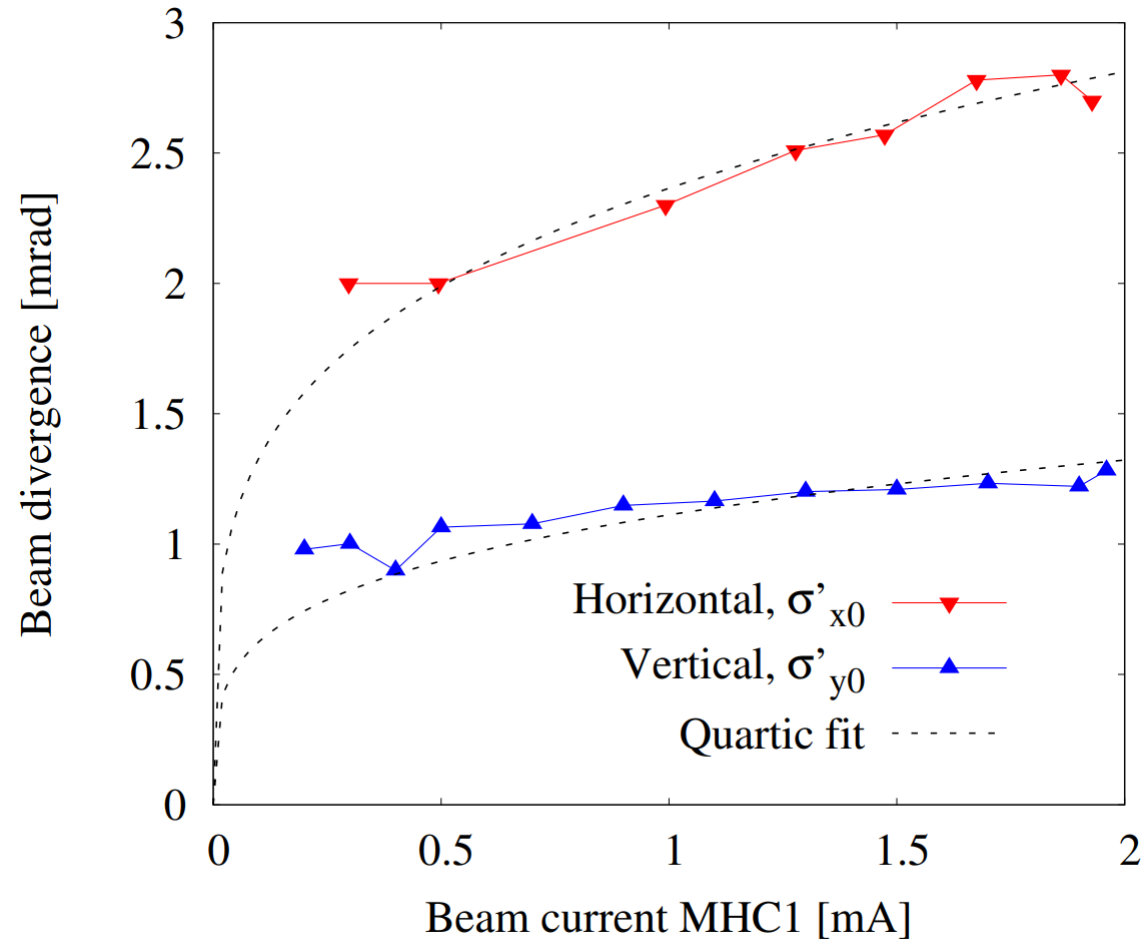

BDSIM-MCNP benchmarking

Alert: We assume a 2 mA pencil proton beam.

Element	Power deposition BDSIM (kW)	Power deposition MCNP (kW)
Target M	17.9	18.7
KHM0	22.9	20.3
KHM1	7.8	8.8
KHM2	0.9	1.3
1st triplet	0.5	-
2nd triplet	0.12	-

