

n2EDM progress

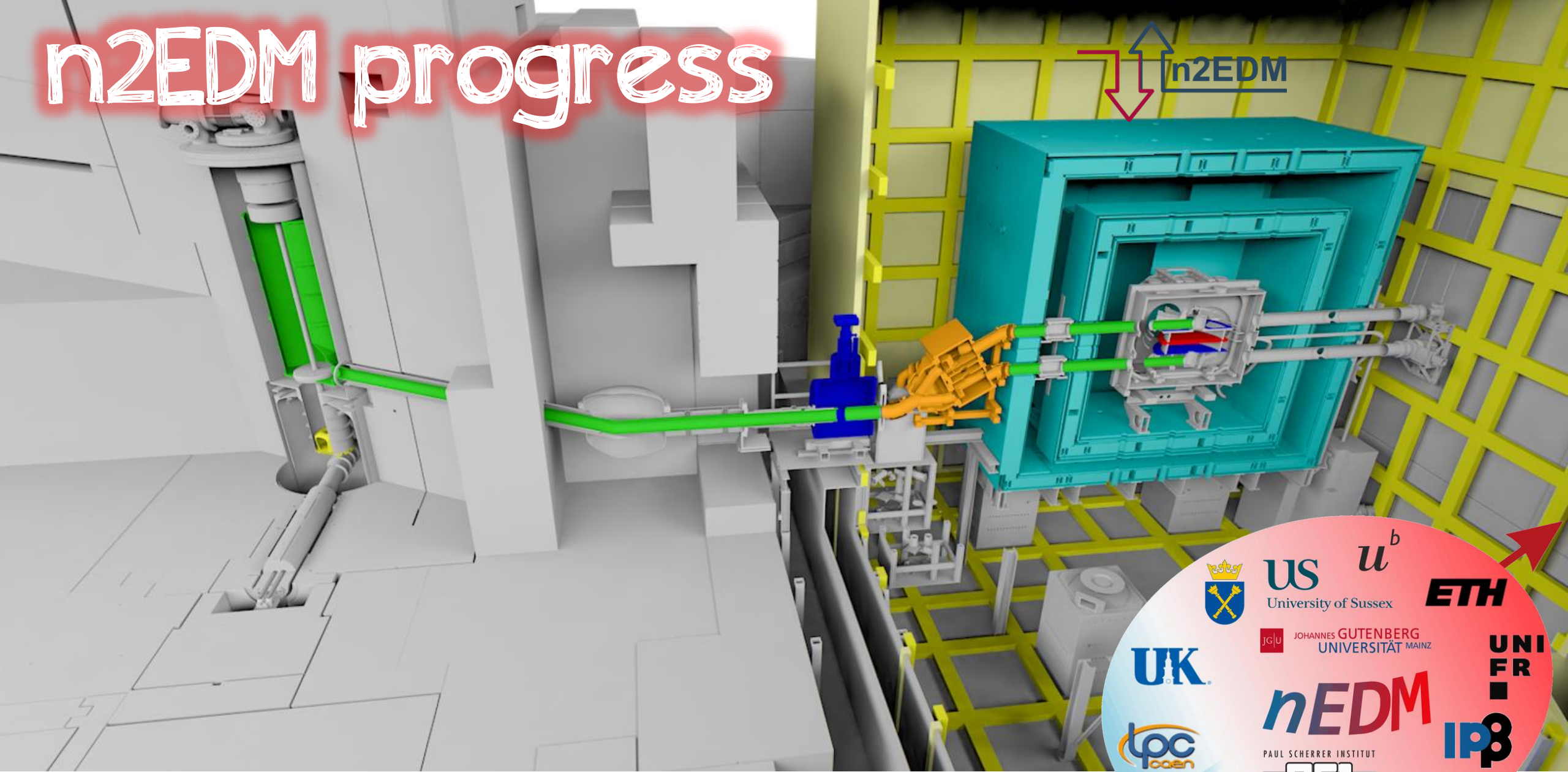

Guillaume Pignol, on behalf of the nEDM collaboration
PSI users' meeting 24.01.2023



EDM: coupling between spin and E-field

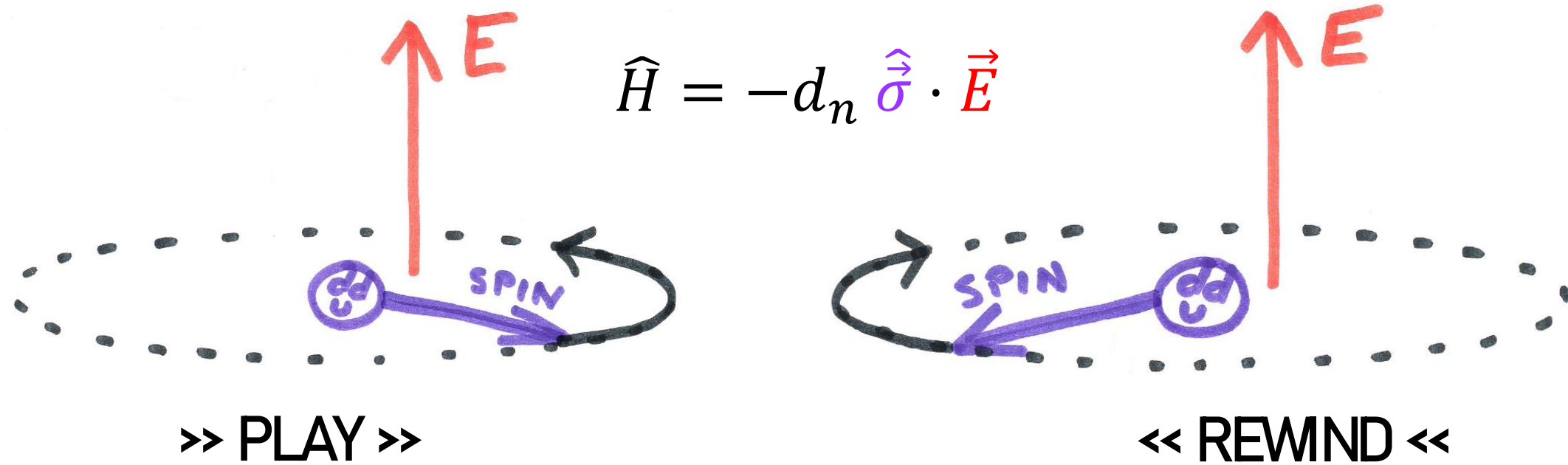

If $d_n \neq 0$ the process and its time reversed version are different.

violation of T \xrightarrow{CPT} violation of CP

The neutron EDM is still zero

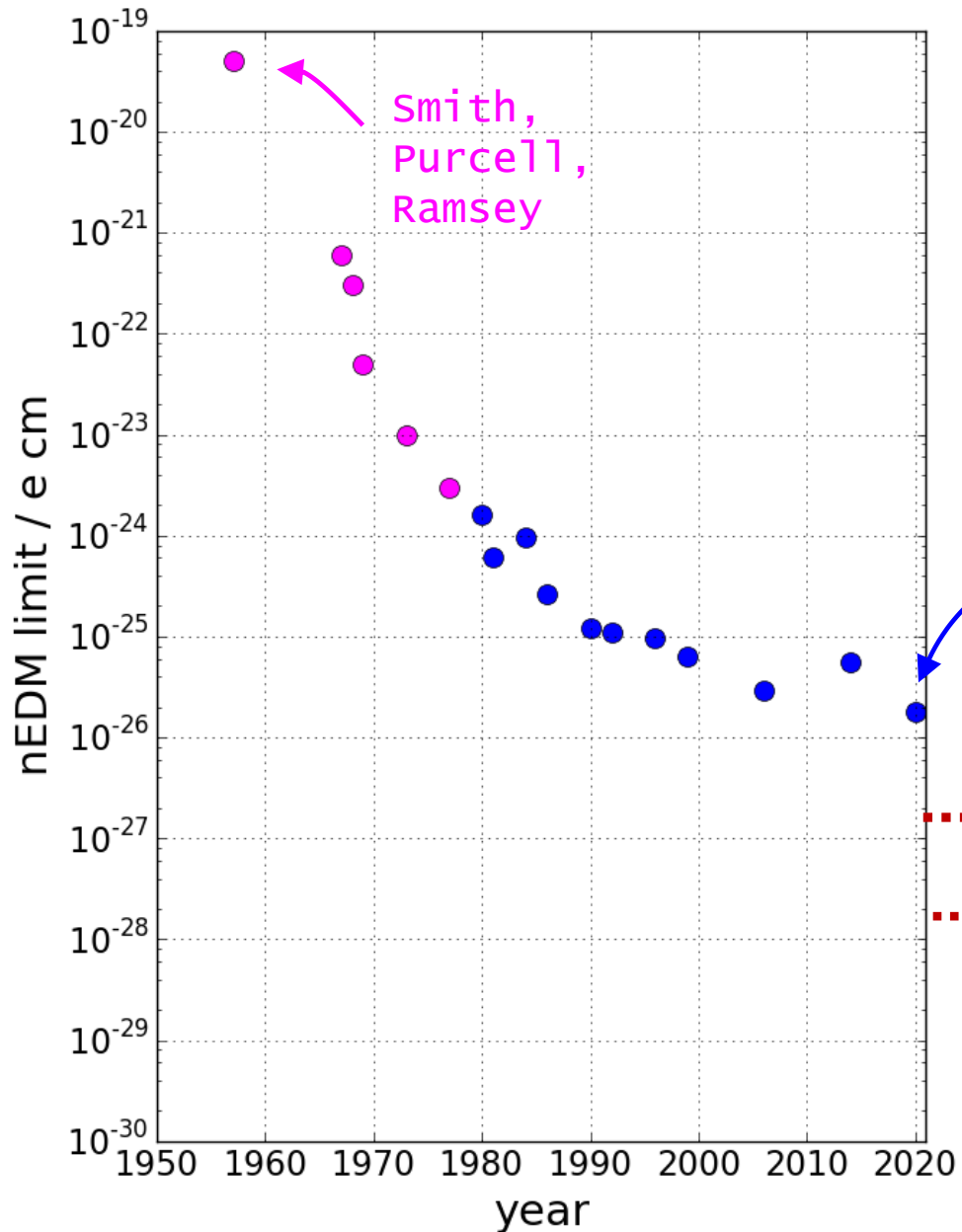

Best limit: nEDM @PSI
Abel et al, PRL 124, 081803 (2020)

$$|d_n| < 1.8 \times 10^{-26} \text{ e cm}$$

Design sensitivity range of 4 experiments

n2EDM @PSI, panEDM @ILL, LANL EDM, tucan @TRIUMF
under construction now

Design sensitivity EDM@SNS, starting 2028

CKM background uncertain, possibly 10^{-31} e cm

Basics of nEDM measurement

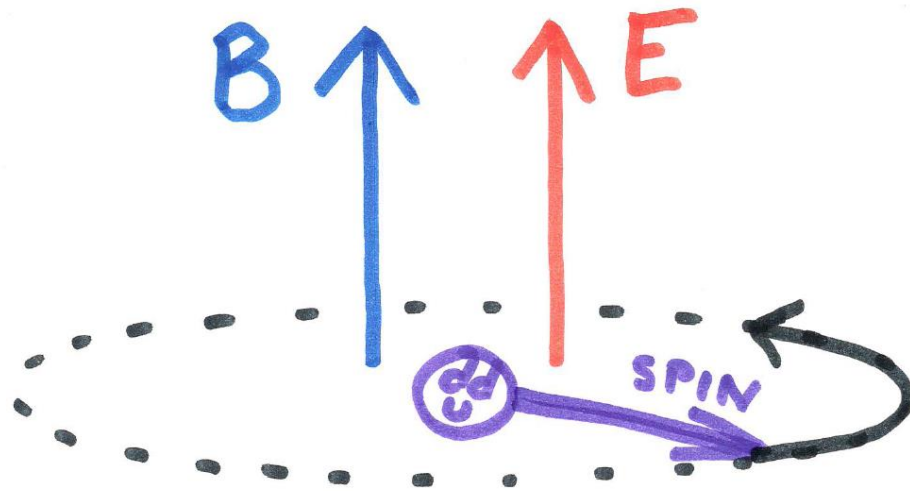

Larmor frequency
 $f = 30 \text{ Hz @ } B = 1 \mu\text{T}$

$$2\pi f = \frac{2\mu_n}{\hbar} B \pm \frac{2d_n}{\hbar} |E|$$

If $d_n = 10^{-26} e \text{ cm}$ and $E = 11 \text{ kV/cm}$
one full turn in a time

$$\frac{\pi\hbar}{dE} = 200 \text{ days}$$

To detect such a minuscule coupling

- Long interaction time
- High intensity/statistics
- Control the magnetic field

- Long interaction time
- High intensity/statistics
- Control the magnetic field

Use Ultracold neutrons

Neutrons with velocity $< 5\text{m/s}$ can undergo total reflection and be stored in material “bottles”

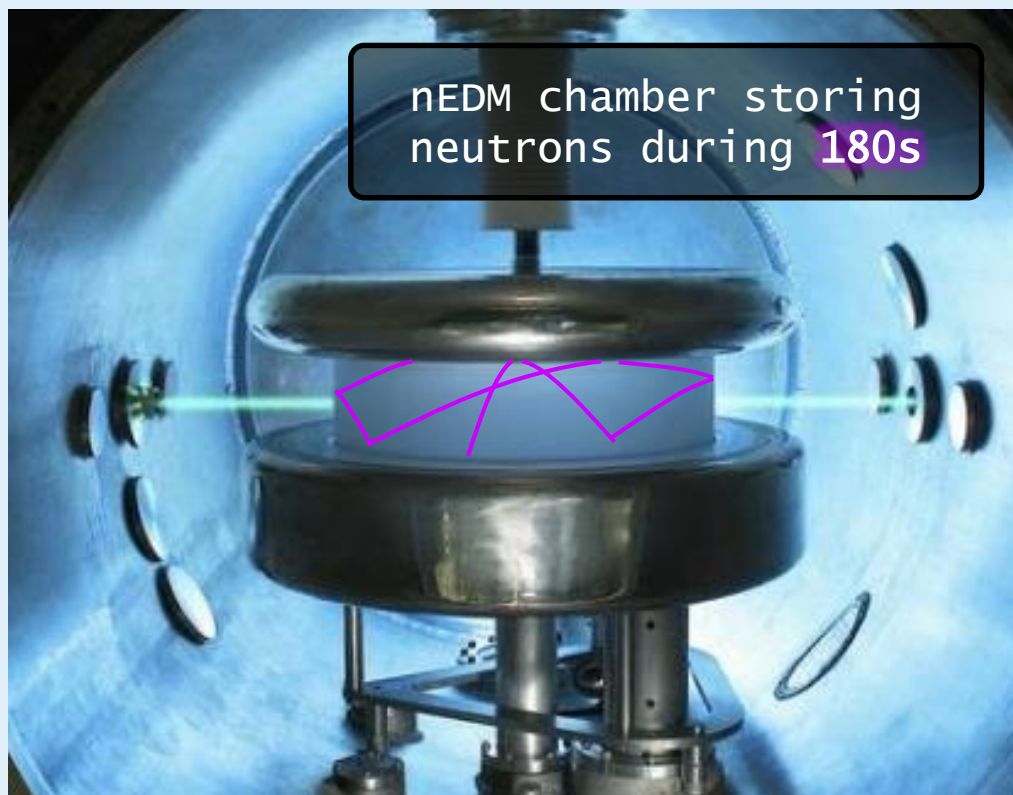

nEDM chamber storing neutrons during 180s

Use big magnetic shielding



+ Use quantum magnetometry
with mercury and cesium atoms

$$d_n = (0.0 \pm 1.1_{\text{stat}} \pm 0.2_{\text{syst}}) \times 10^{-26} \text{ ecm}$$

Limited by the number of UCNS

Uniformity of the B-field

The design of the n2EDM experiment,
Ayres et al, EPJC (2021)

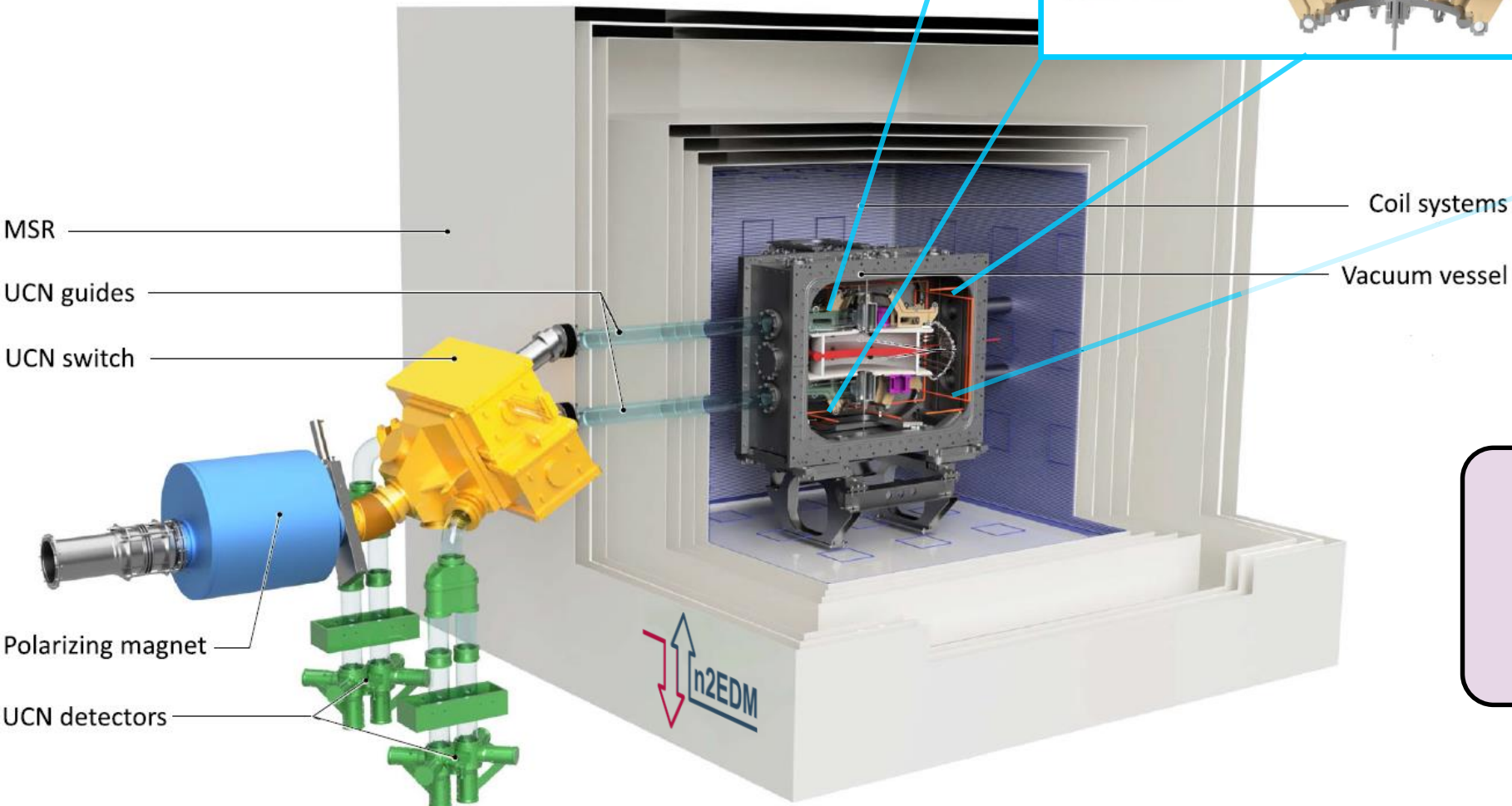
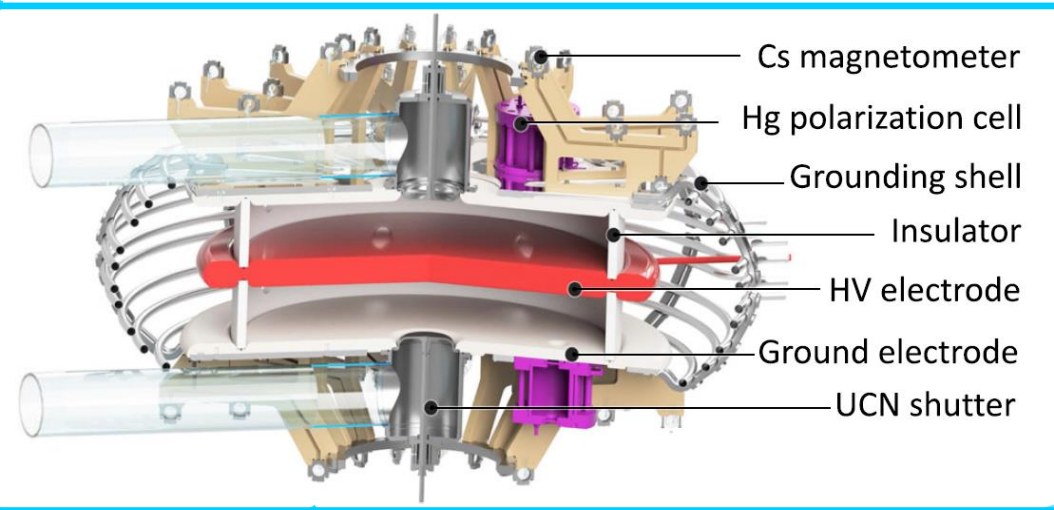

A large (\varnothing 80 cm)
double-chamber
UCN apparatus

The design of the n2EDM experiment,
Ayres et al, EPJC (2021)

Baseline design

	nEDM 2016	n2EDM
Chamber	DLC and dPS	DLC and dPS
Diameter D	47 cm	80 cm
N (per cycle)	15,000	121,000
T	180 s	180 s
E	11 kV/cm	15 kV/cm
α	0.75	0.8
$\sigma(f_n)$ per cycle	9.6 μ Hz	3.2 μ Hz
$\sigma(d_n)$ per day	11×10^{-26} e cm	2.6×10^{-26} e cm
$\sigma(d_n)$ (final)	9.5×10^{-27} e cm	1.1×10^{-27} e cm

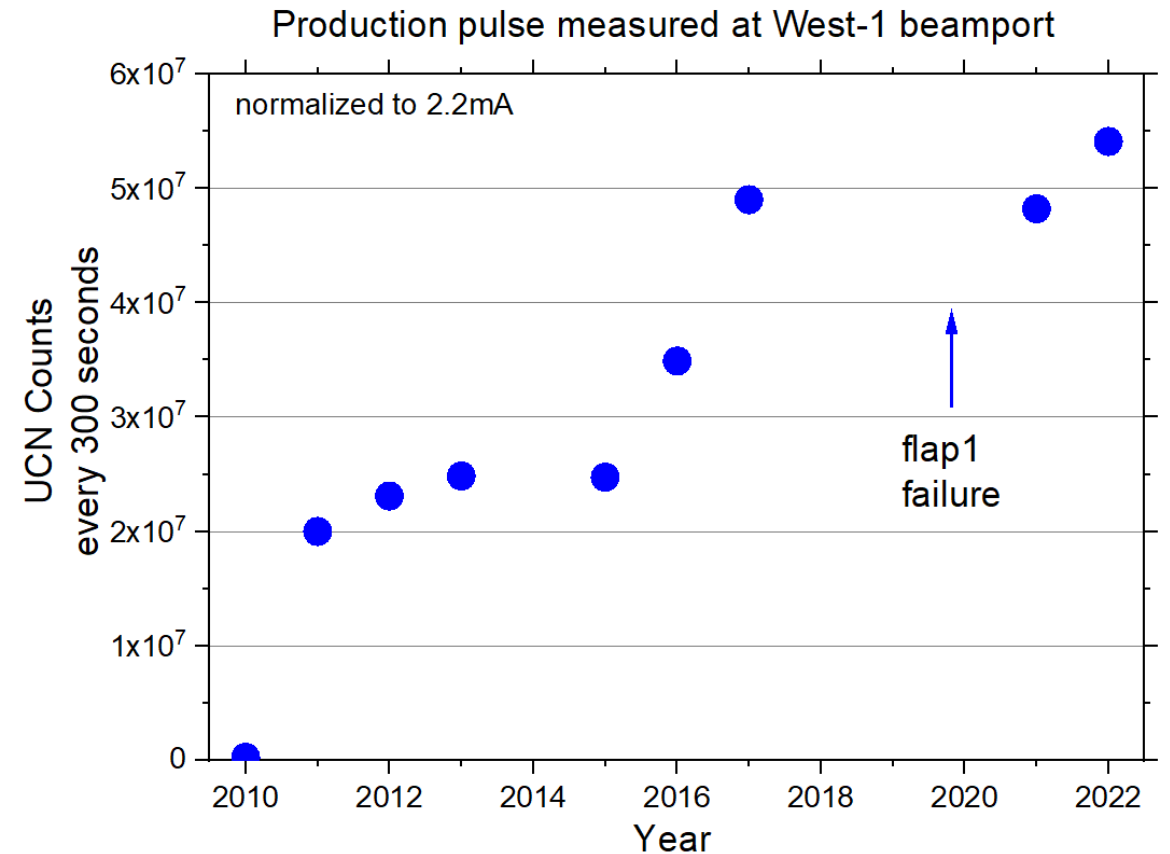

n2EDM designed to improve the sensitivity by factor 10,
with 500 data days, based on UCN source performance established in 2016

n2EDM construction

Nov 2017 → → → Dec 2019

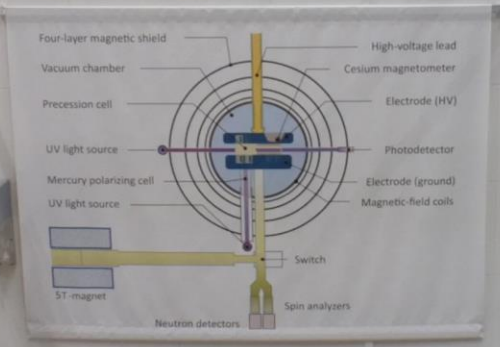

Commissioning of the n2EDM Magnetically Shielded Room in 2020

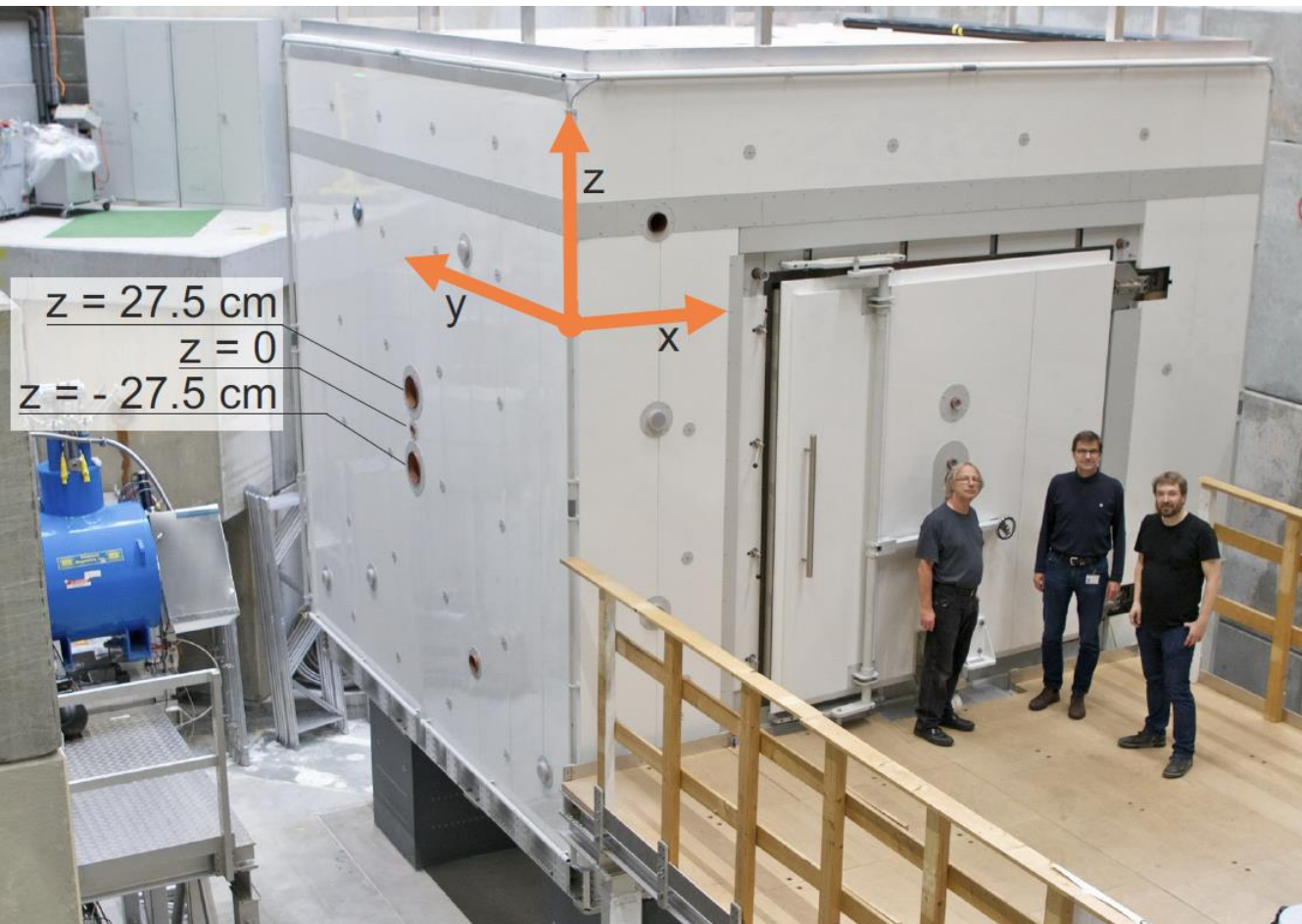

- Setup and optimization of the degaussing
- Characterization of the remanent field
- Measurement of the shielding factors

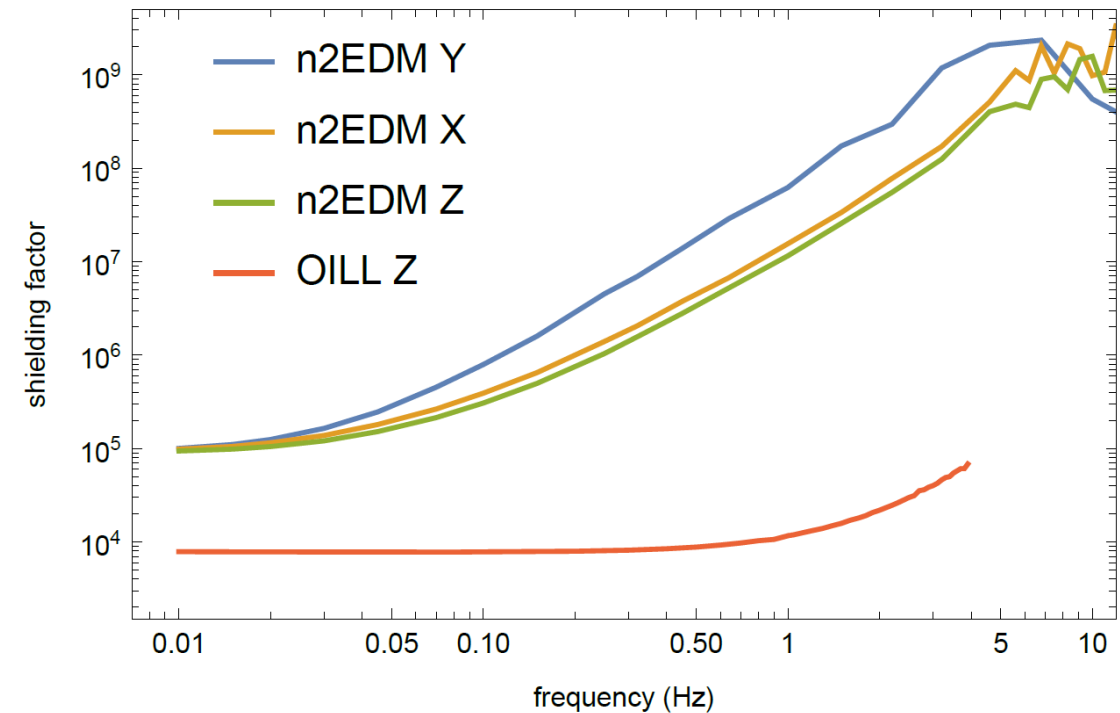

[The very large n2EDM magnetically shielded room with an exceptional performance for fundamental physics measurements, Review of Scientific Instruments 93, 095105 \(2022\)](#)

Active Magnetic Shield built in 2021

- 8 coils (x,y,z, G1...G5)
- 500 loops
- 55km wires



n2EDM in 2021



Installation internal coil system

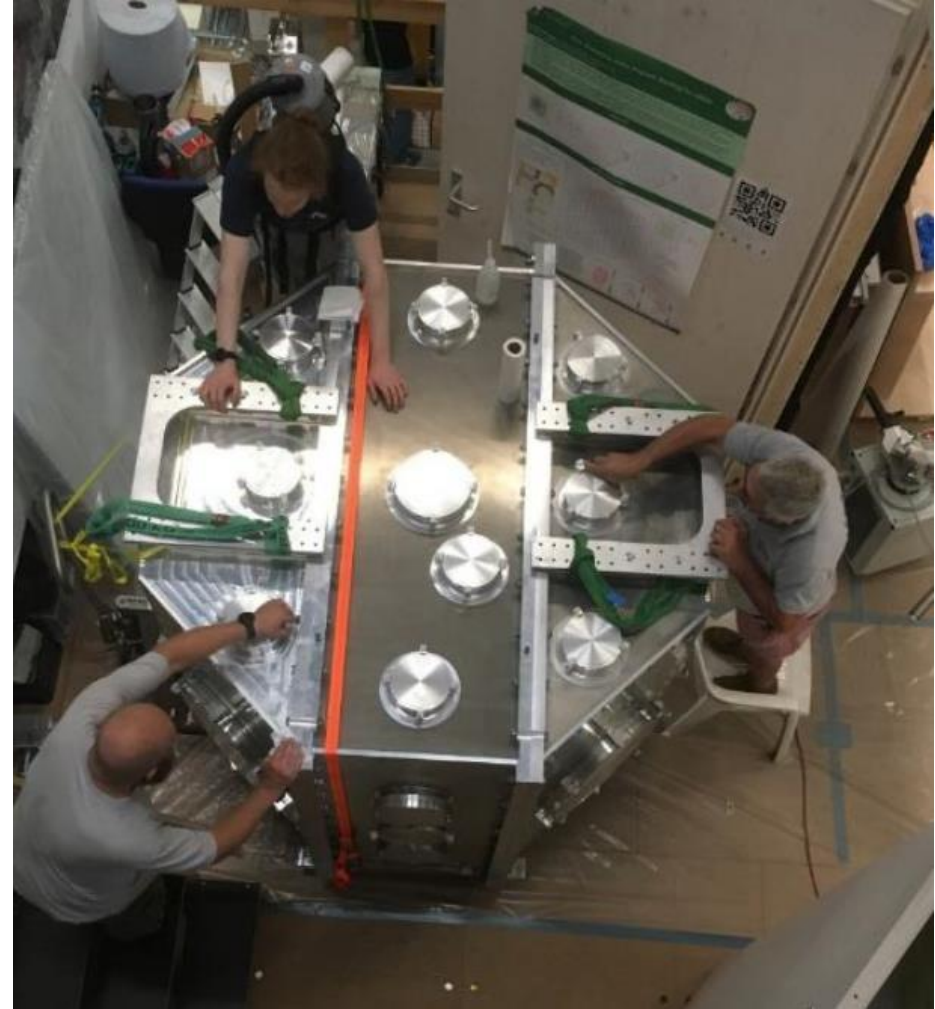

Delivery non-magnetic vacuum vessel

B-field mapping campaign 2022

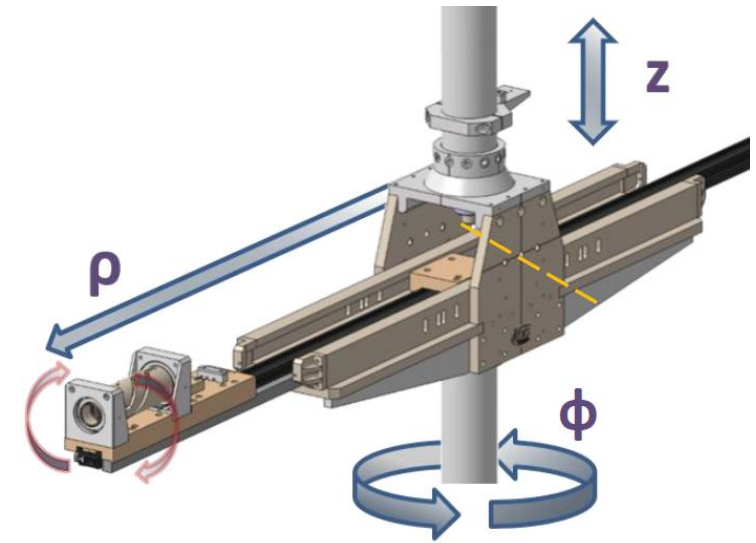
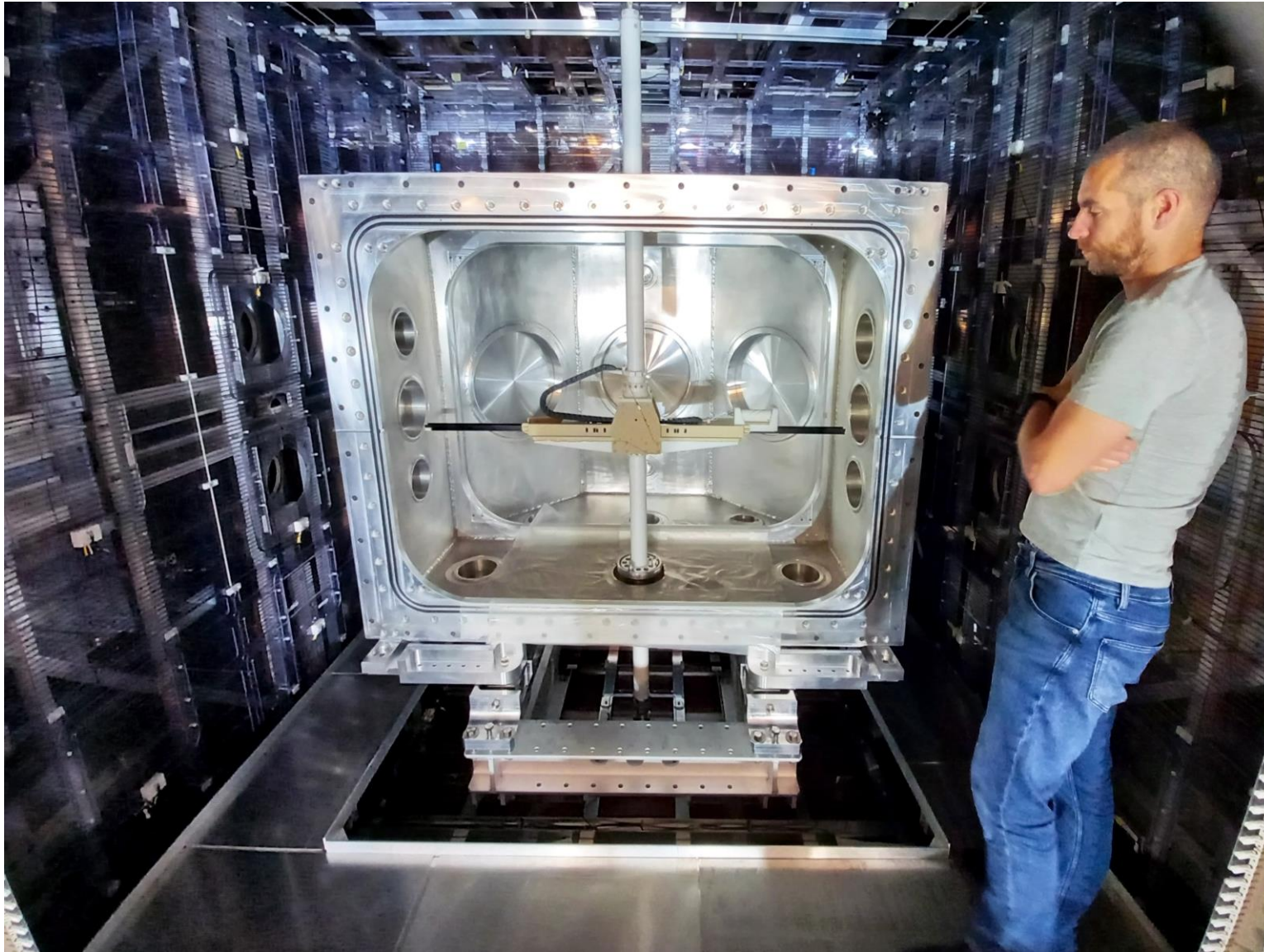

Installation of the mapper in the empty vacuum vessel

Uniformity of the vertical B-field

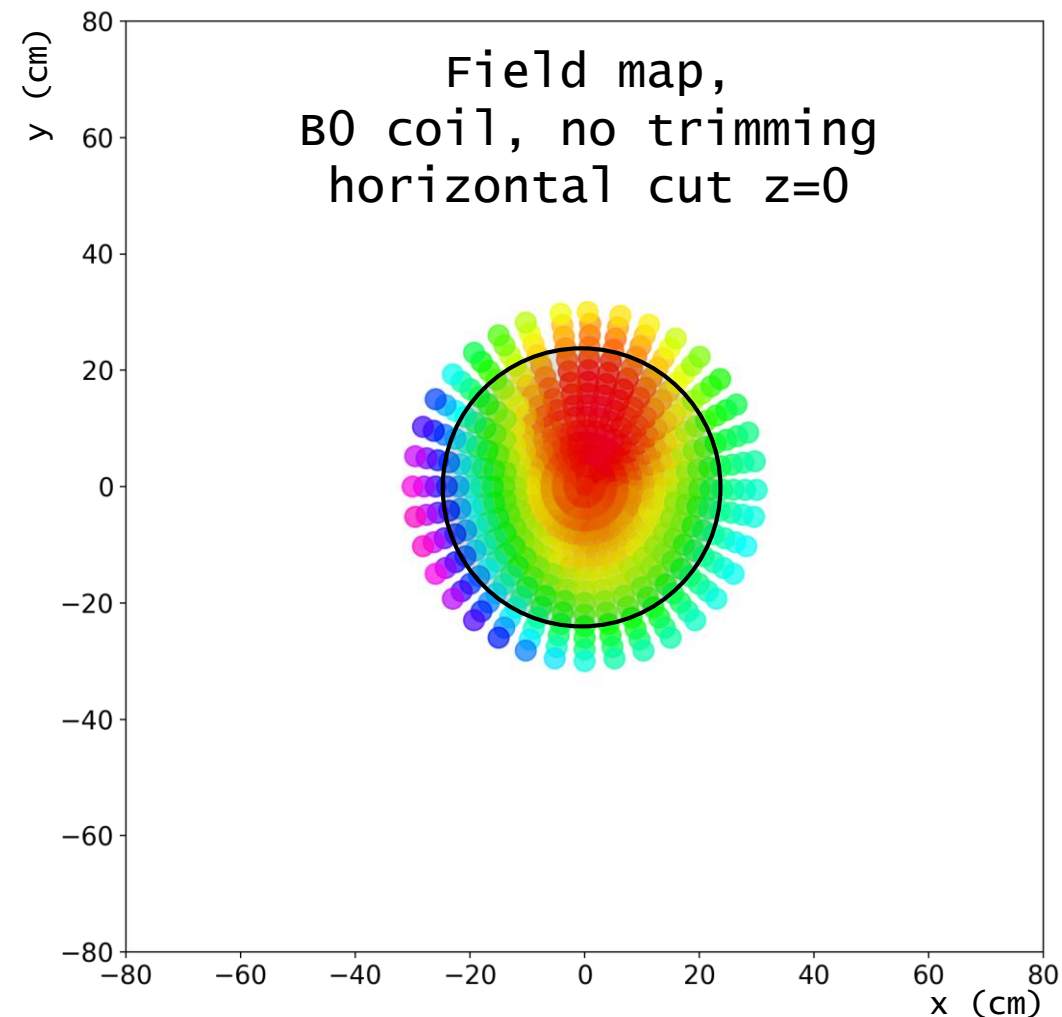

B_z (μT)

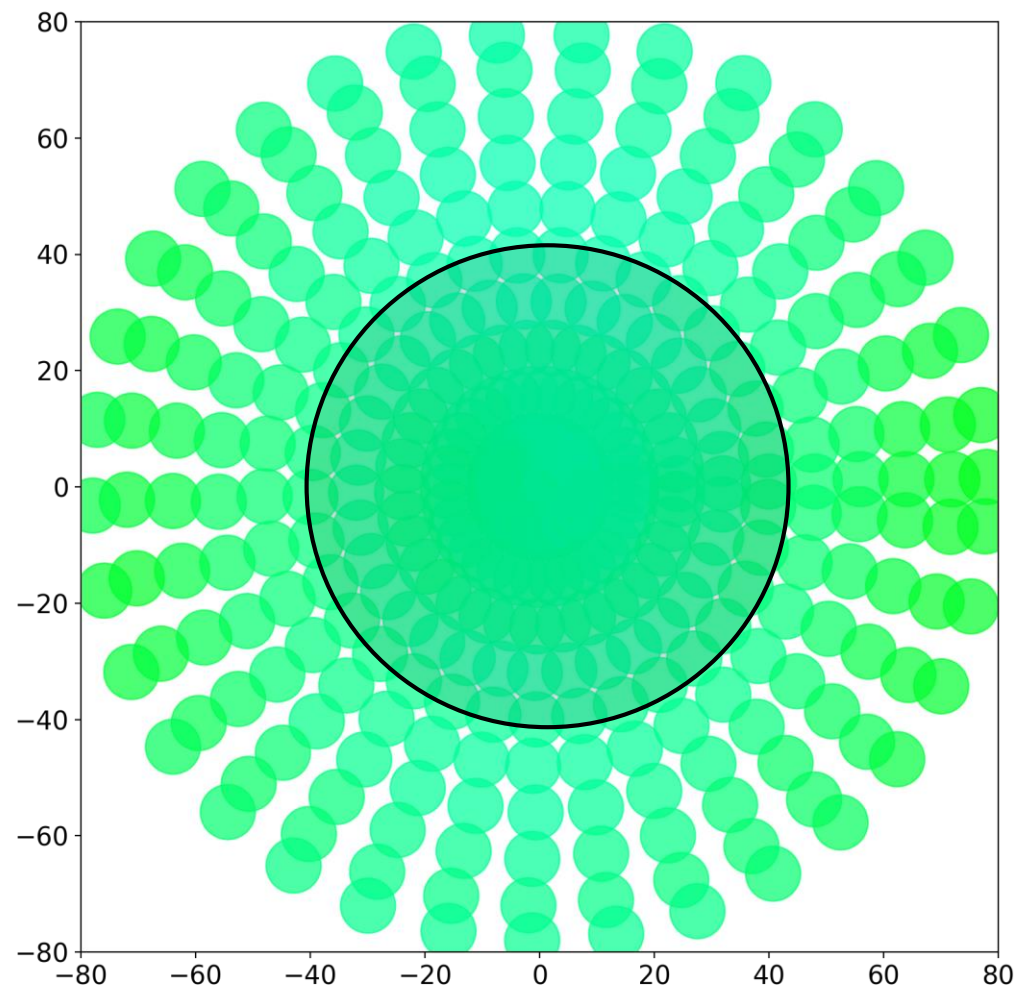
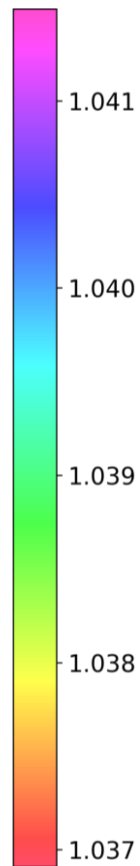

nEDM 2017 $\sigma(B_z) = 860$ pT

In the precession chamber \varnothing 47 cm

n2EDM 2022 $\sigma(B_z) = 60$ pT

In one chamber \varnothing 80 cm

Production precession chambers



Ground electrodes



High voltage electrode

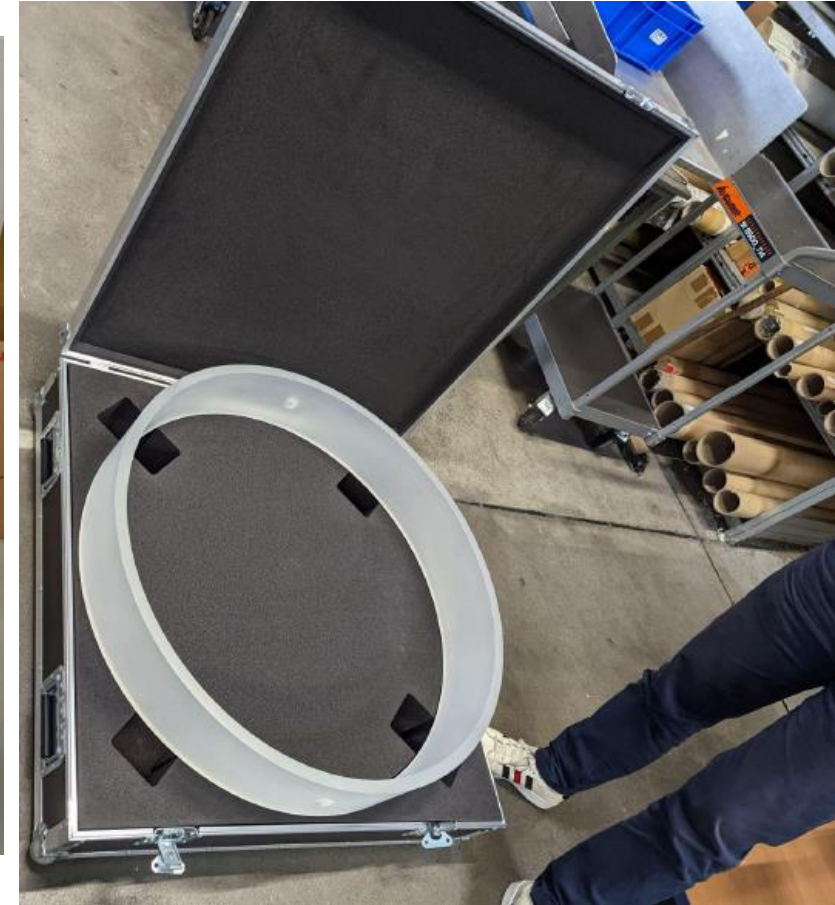

Insulator ring

UCN transport and detection



UCN switch nearly operational

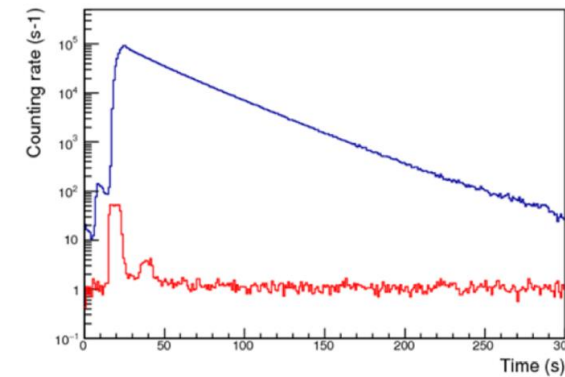
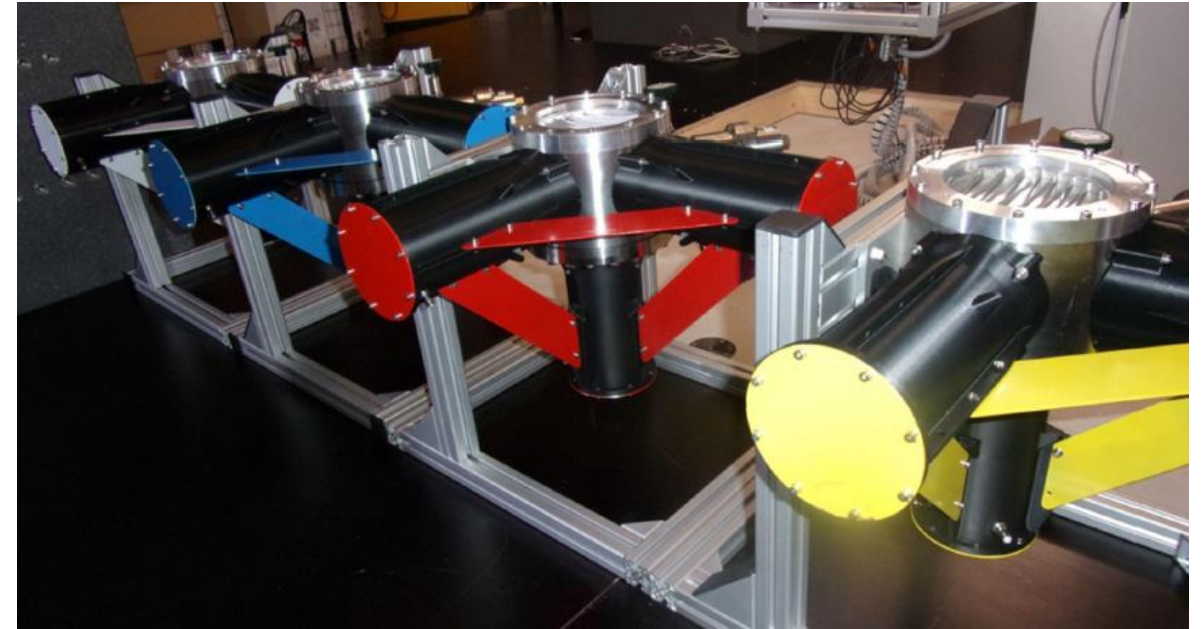

4 UCN
detectors
operational

Conclusions



n2EDM magnetically operational (MSR+B0)

- Big volume: 6 fold increased /nEDM
 - Order of magnitude improved shielding factor
 - Order of magnitude improved uniformity
- => Satisfies the requirements => Ready for physics!

Ultracold neutrons
transport, storage, detection:
most of it is ready for installation

Schedule:
n2EDM ready for physics end of 2023

