

Targets & Calibration

Lithium Measurement Plan

Katharina - 18.08.2023

Targets/Sources

7 slots on target ladder

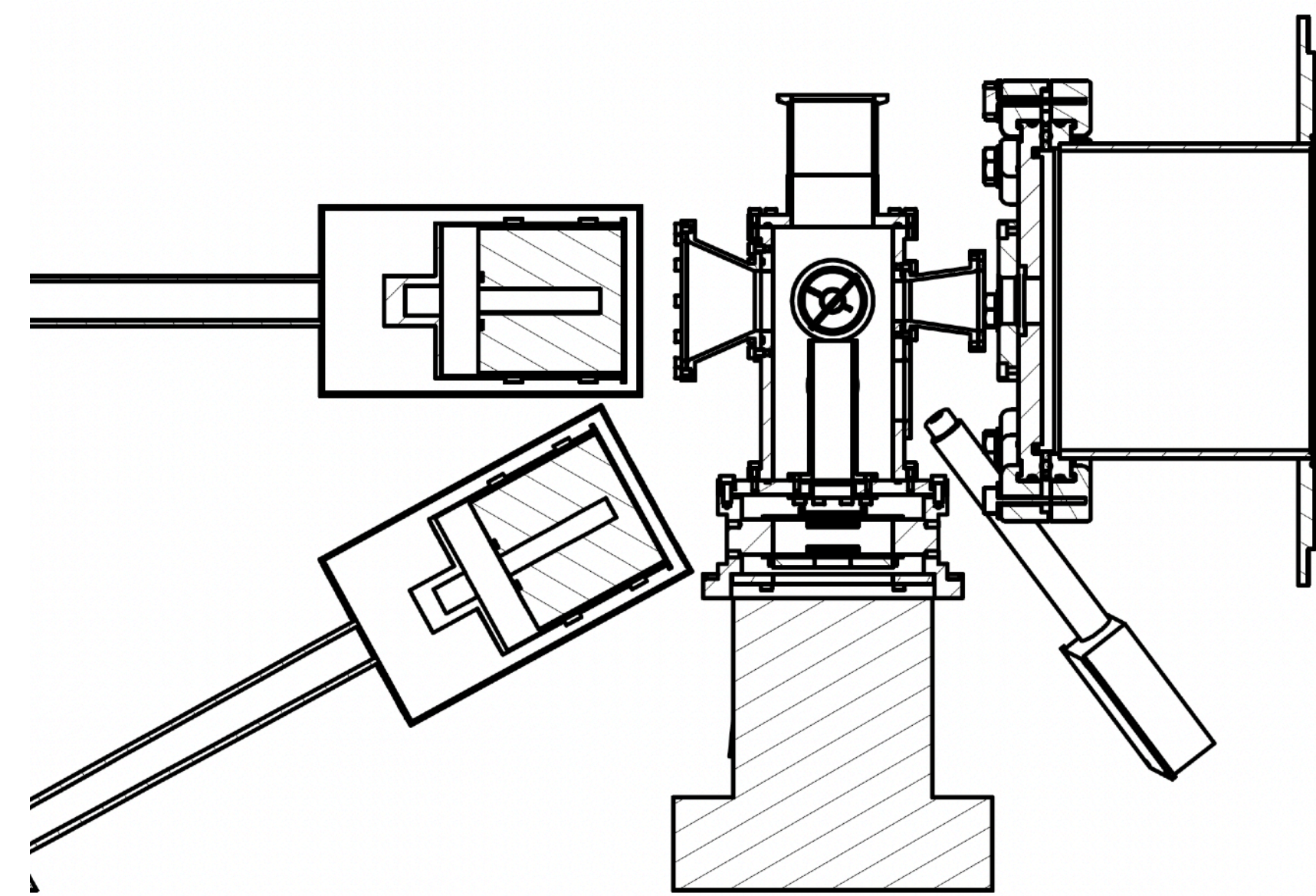

Lithium

Calibration

Carbon



Targets/Sources

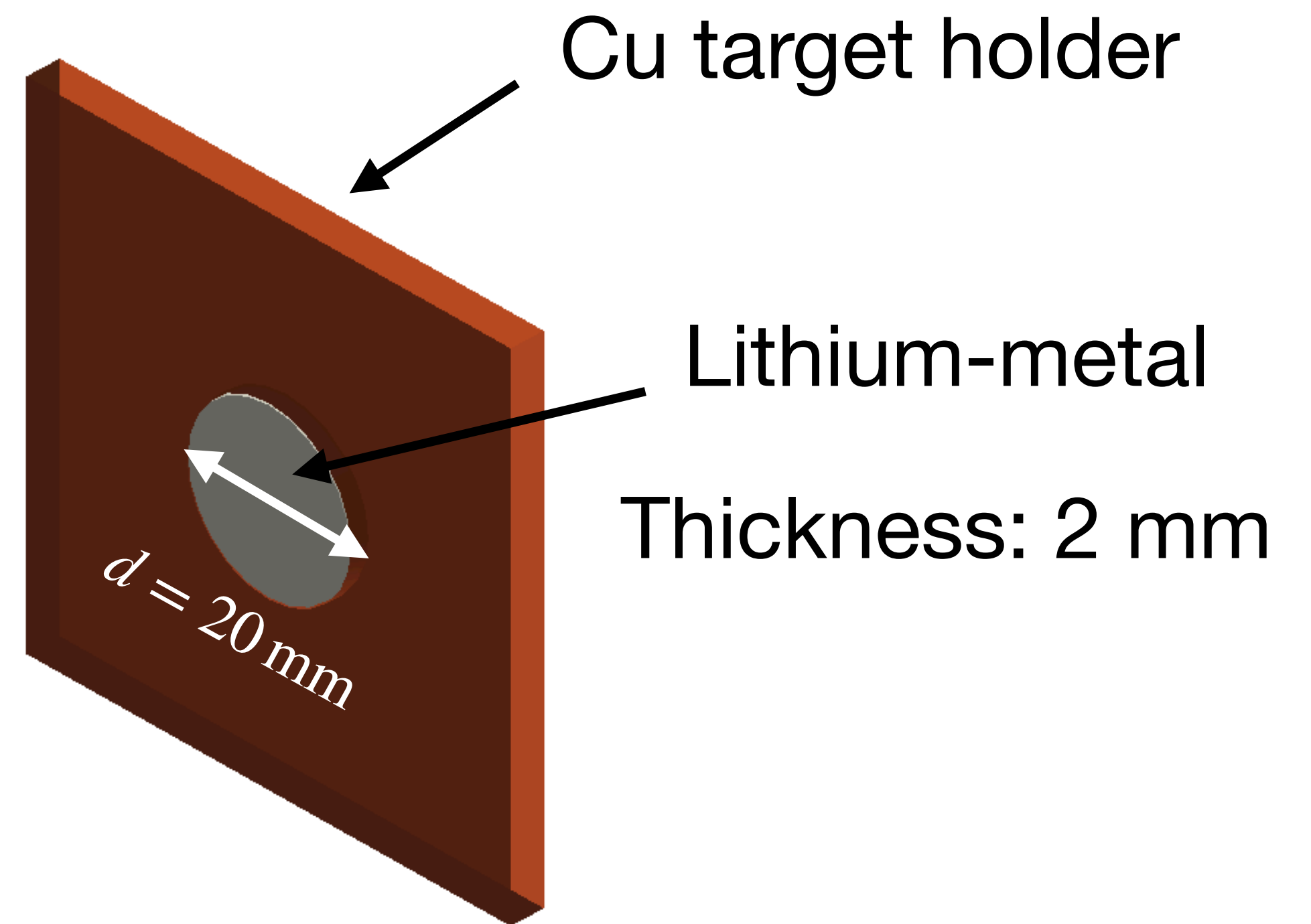
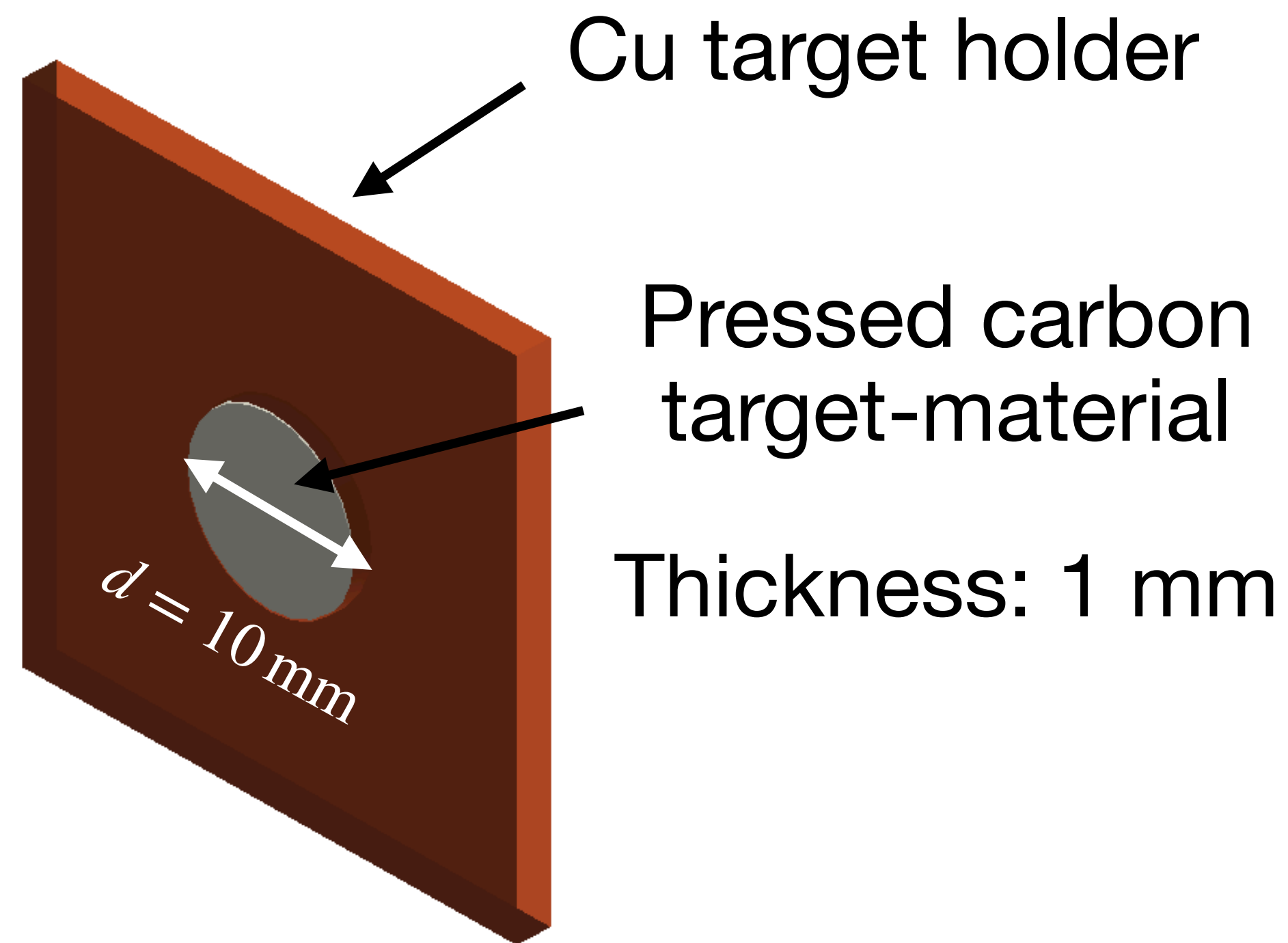

Stopping Efficiency

G4Beamline Simulation

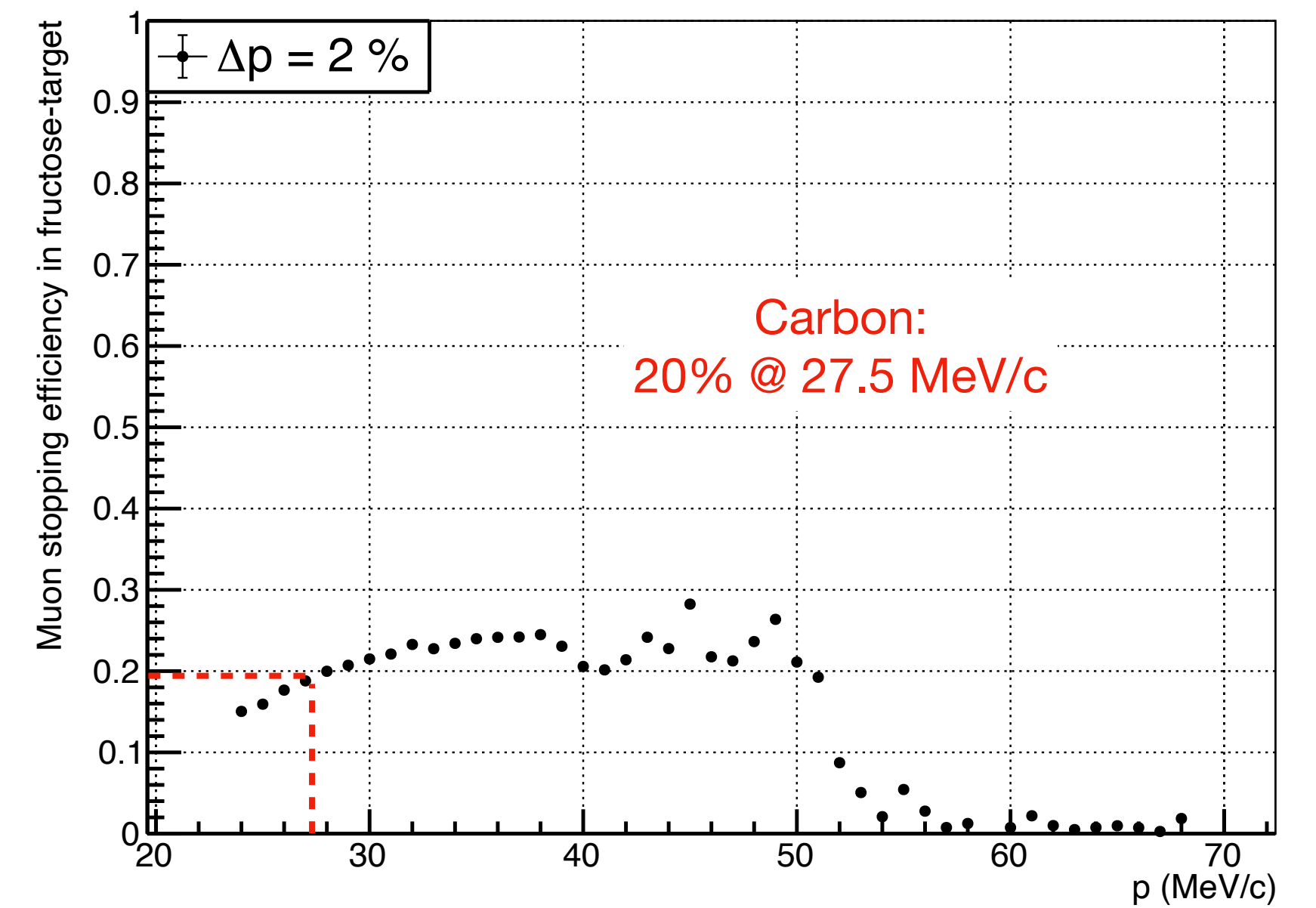
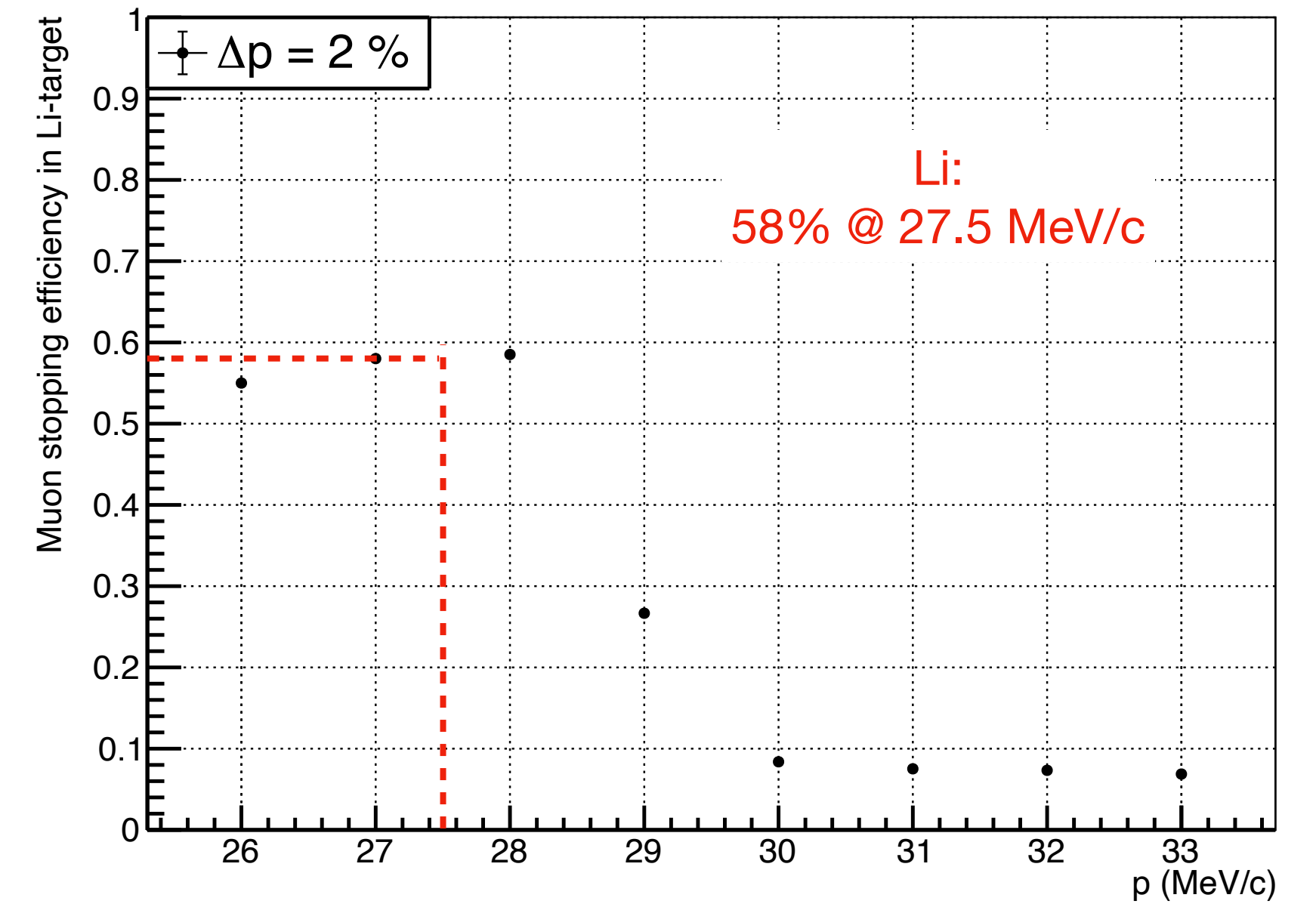
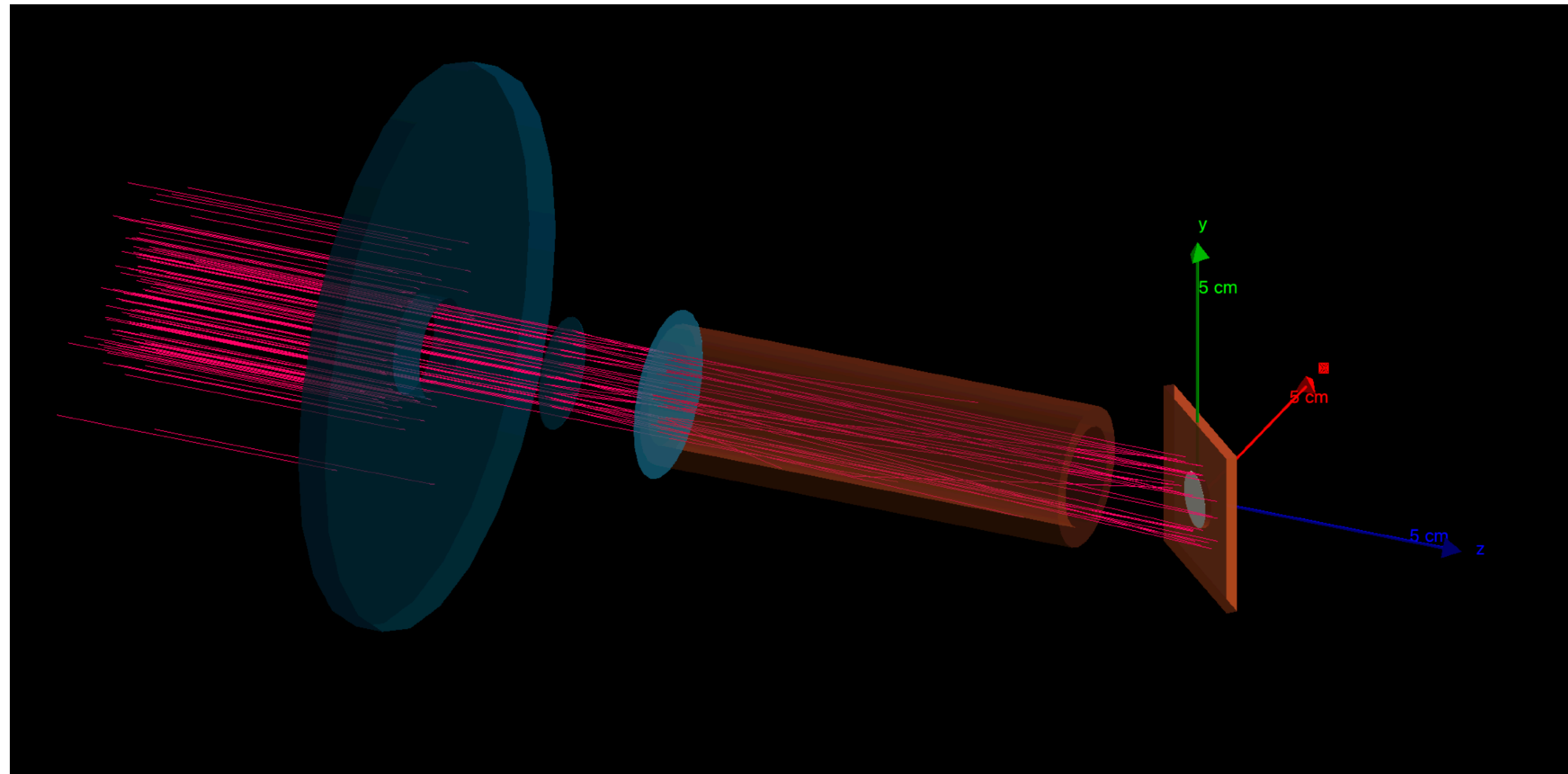

Li Measurement Time Schedule

Net beam time (excl. maintenance period):
~ 128 h - 136 h

Sequence	
Target	Time
Li/C	1 h
Sources calibration	0.5 h
XRF calibration	10 min
Li/C	1 h
Sources calibration	0.5 h
...	...

?

?

Target	Approx. Duration/h
⁶ Li	5.0
Nat. Li	5.0
¹² C	3.0
¹³ C	3.0
Nat. C	3.0
Sources calibration	9.5
XRF calibration	3.5
Beam tuning	?
Detector tuning	?
Total	32.0