

# Recent Magnetic Measurement Activities at Fermilab

09Oct2024

J. DiMarco, , D. Assell, M. Baldini, G. Chlachidze, D. Harding, V. Kashikhin, M. Kifarkis, O. Kiemschies, V. Nikolic, J. Nogiec, T. Strauss, M. Tartaglia, D. Walbridge

***Abstract***— Magnetic measurements are performed at Fermilab for both projects internal to the lab and as well as work for other laboratories. This talk briefly overviews the current projects and types of measurements we're currently involved in, focusing on the more interesting or challenging.

**Recent projects:**

- **US-LHC Hi-Lumi Accelerator Upgrade Project (AUP)**
- **Magnets built for Oak Ridge National Lab (ORNL) Proton Power Upgrade (PPU)**
- **Fermilab's Proton Improvement Plan (PIP-II)**

**Measurements include**

- **Large magnet lengths and apertures**
- **Curved magnet trajectories**
- **Measurements during AC magnet excitation.**

## US-LHC Hi-Lumi Accelerator Upgrade Project (AUP)

The HL-LHC AUP Project is tasked with the delivery of 10 MQXFA Cryomodules (CM) in the next few years.

These are large-aperture (150 mm) low- $\beta$  focusing Nb<sub>3</sub>Sn quadrupoles operating at 1.9K, and bring Nb<sub>3</sub>Sn technology into use for accelerator applications.

Fermilab is in charge of the final assembly of 10 CM (2 x 4.2 m magnets in each) and final magnetic measurements at 1.9K operating temperature.

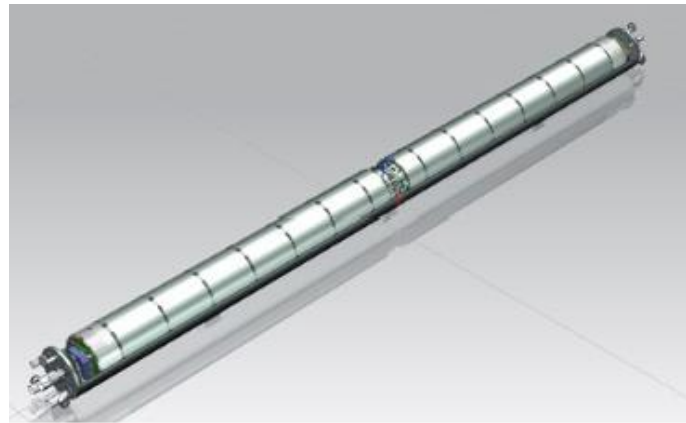

# Magnetic measurements at horizontal test bench

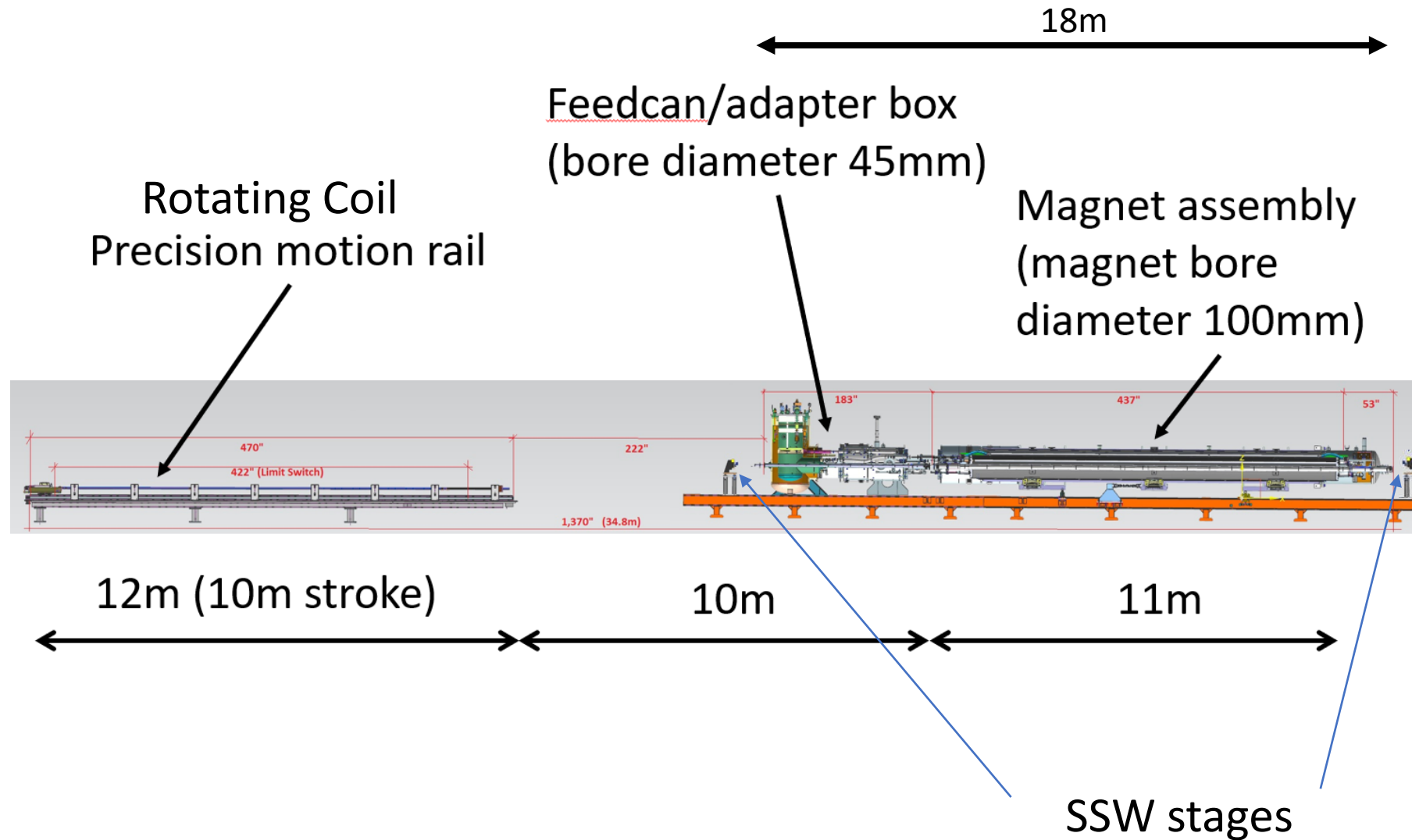

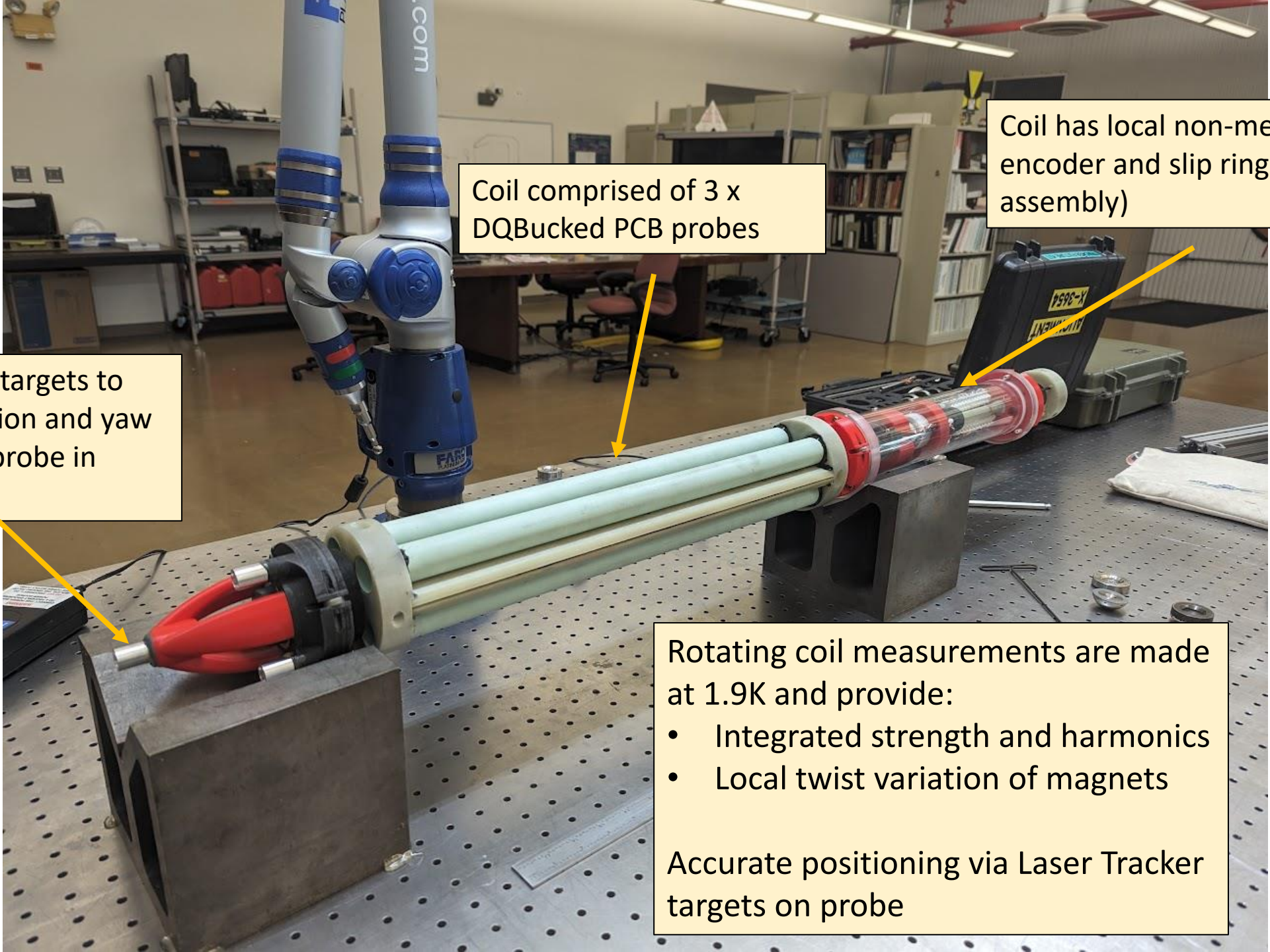

Laser tracker targets to provide position and yaw and pitch of probe in magnet

Coil comprised of 3 x DQBucked PCB probes

Coil has local non-metallic encoder and slip rings (FERRET assembly)

Rotating coil measurements are made at 1.9K and provide:

- Integrated strength and harmonics
- Local twist variation of magnets

Accurate positioning via Laser Tracker targets on probe

Rotating coil 'FERRET' probe

Probe has 436mm-long winding and two 'back-to-back' 109mm-long windings.

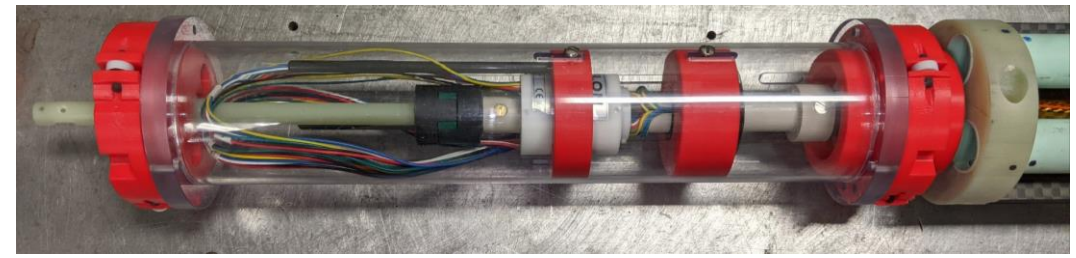
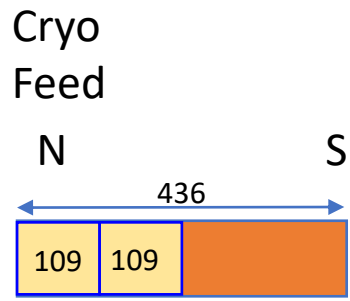

Local encoder and slipping

Supports for push tube

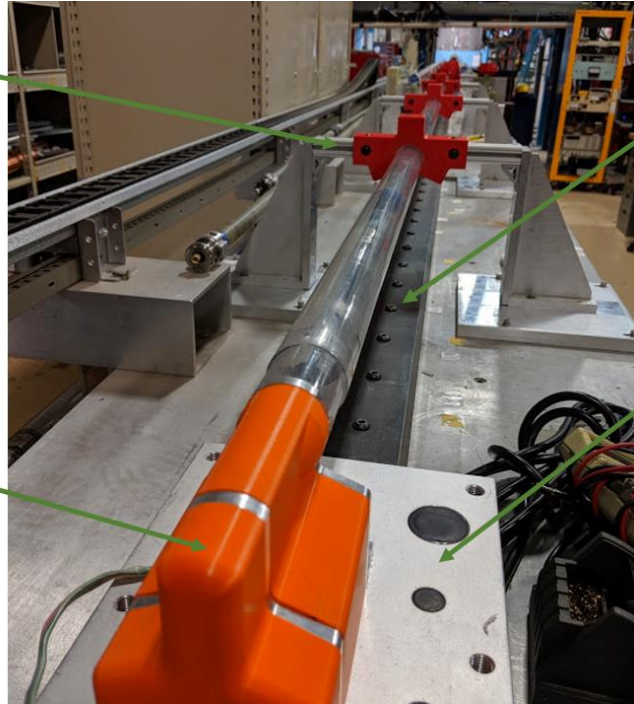

Rail

Rail drive carriage

Coil drive shaft rotation motor



PCB probes stiffened with carbon fiber or G10

Laser tracker targets visible from non-drive end



**22m-long**, 6mm diameter carbon fiber rotating drive shaft and polycarbonate push-tube



Axial positioning using the 22m-long polycarbonate 'push-tube' having a 6.35 mm carbon fiber rotating shaft

Note that the push tube is supported and motor assembly constructed so that there are no need for moving 'gates' during translation.





### LQXFA01, 16233A, 1.9K, 436mm probe

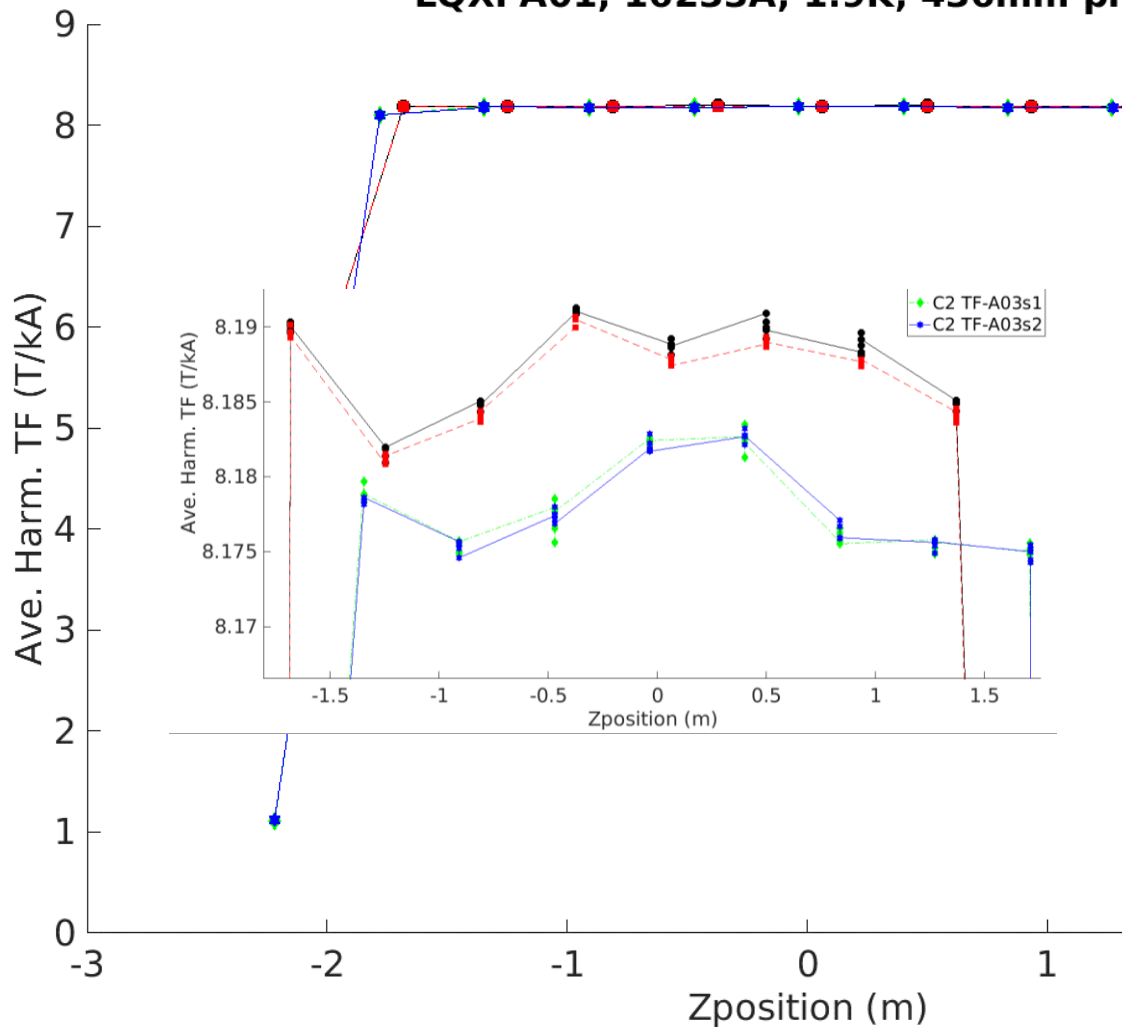

Strength and harmonics (compared to measurements at BNL) for the 1<sup>st</sup> CM

### LQXFA01 Integrated harmonics Nominal Current, 16233 A

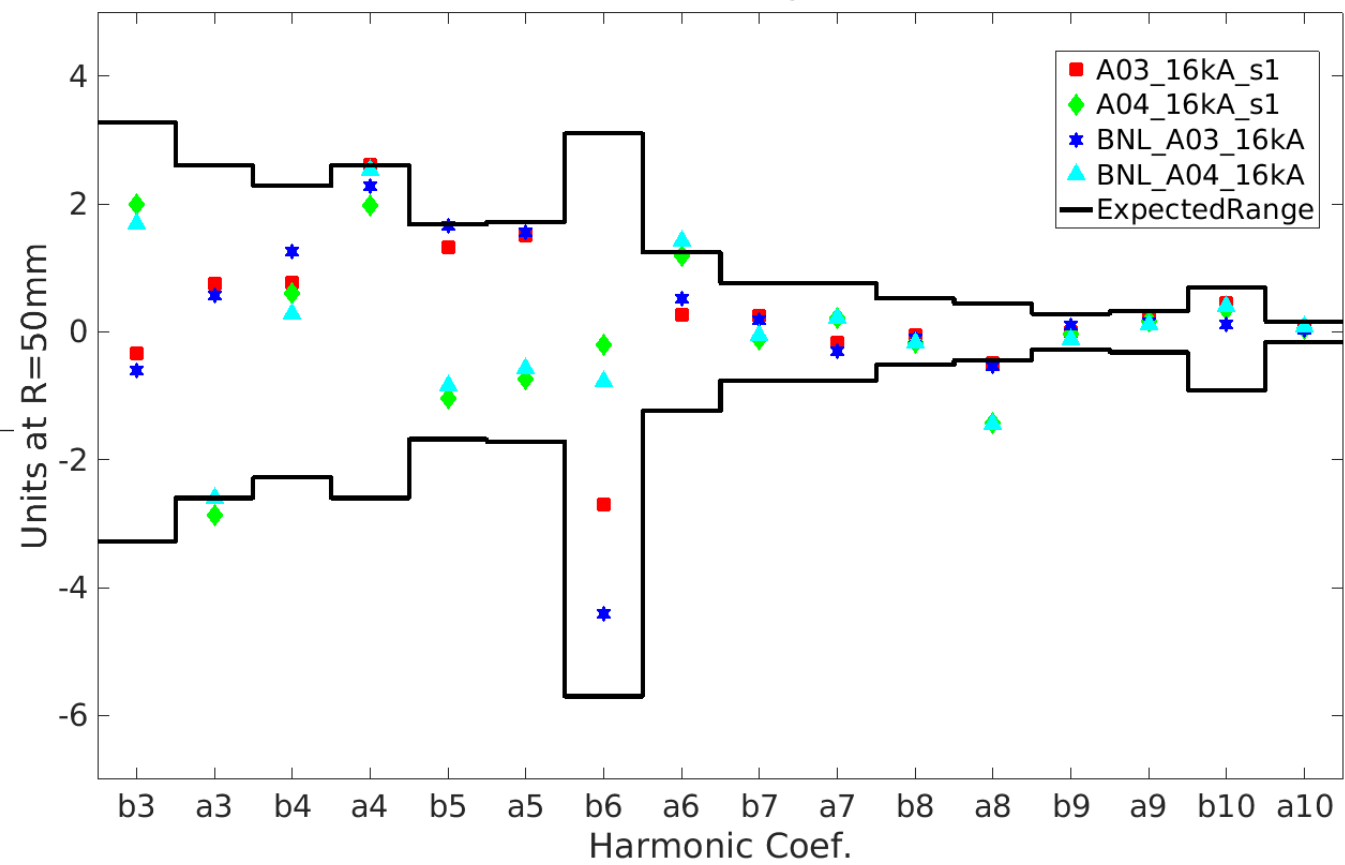

# Dual-probe technique of measuring local magnet twist

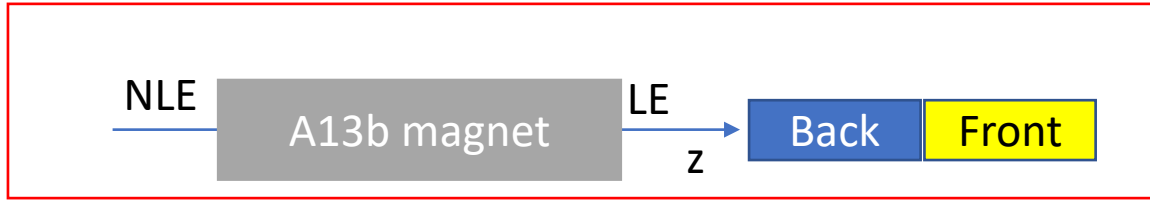

← Scan is made starting at NLE so that “back” probe trails “front” probe

Two probes of same length –  
Z-scan is performed such that every step overlaps the previous front probe position with the current back probe position

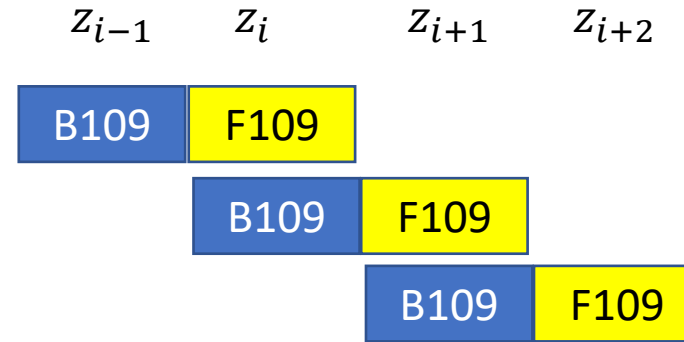

The cumulative sum of the difference between probes yields the magnet variation (the **calibrated probe offset is subtracted** when determining the differences)

$$\theta_r(i) = \sum_{n=1}^i (\theta_{Fn} - \theta_{Bn}) - \theta_{FB\_offset}$$

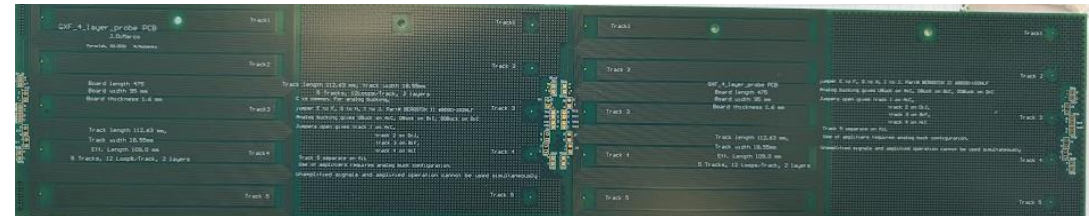

# FieldAngleMeas LQXFA01\_A03A04 Cold TC2, 6kA 31Jul2023

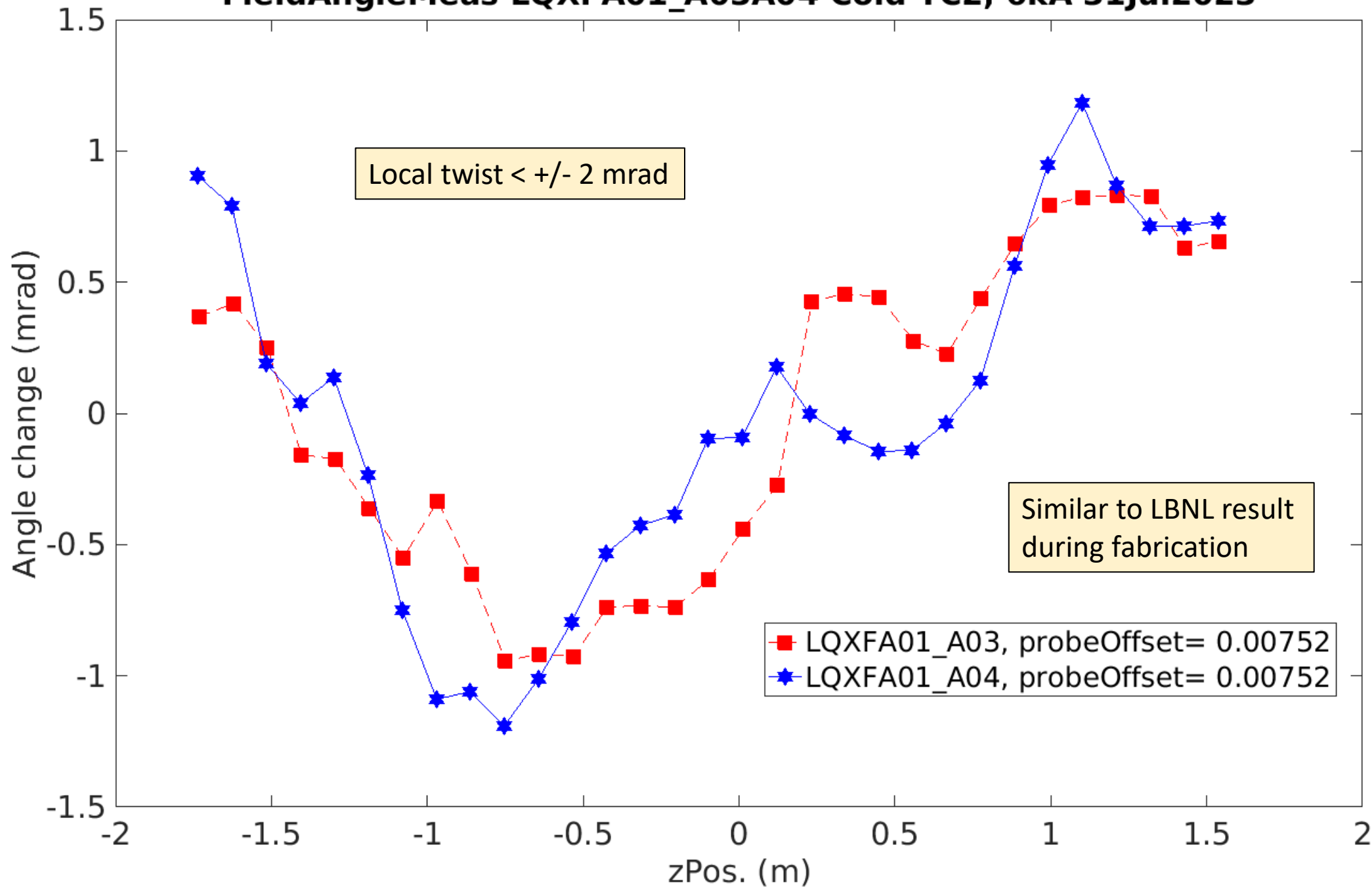



MQXFA04

MQXFA03

SSW system in use during fabrication

MQXFA03/MQXFA04 Alignment  
After move to average axis  
23Aug2023 - cold TC2, 2K

**Horizontal Offsets  
plan view**

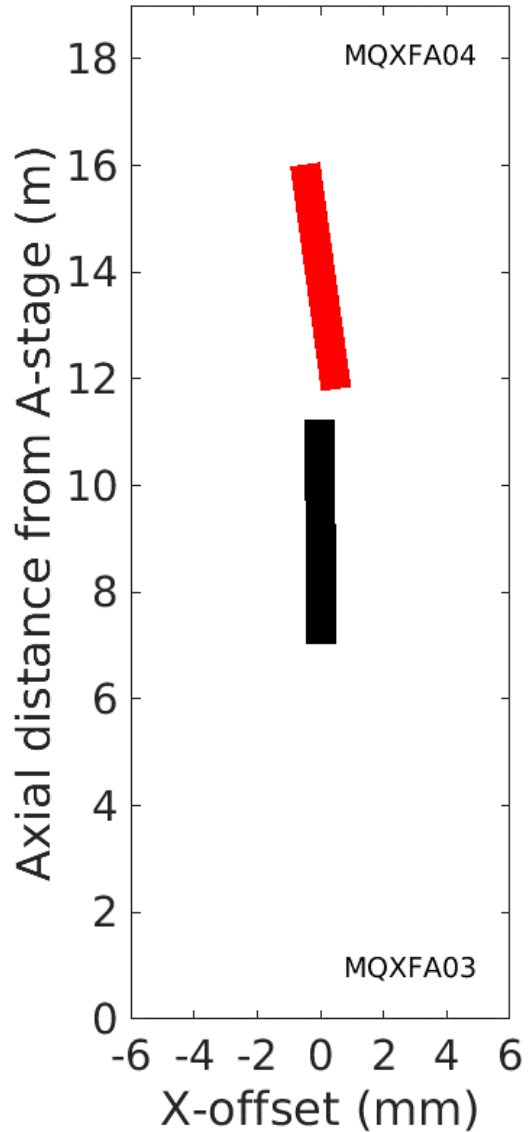

MQXFA03 Lead End: X= 0.042, Y= 0.394 mm  
MQXFA03 Interface End: X= -0.030, Y= -0.402 mm  
MQXFA04 Interface End: X= 0.498, Y= -0.676 mm  
MQXFA04 Lead End: X= -0.482, Y= 0.681 mm

MQXFA03 roll angle = 4.59 mrad  
MQXFA04 roll angle = 2.26 mrad  
Delta angle = 2.32 mrad  
Ave angle = 3.42 mrad

**Vertical Offsets  
profile view**

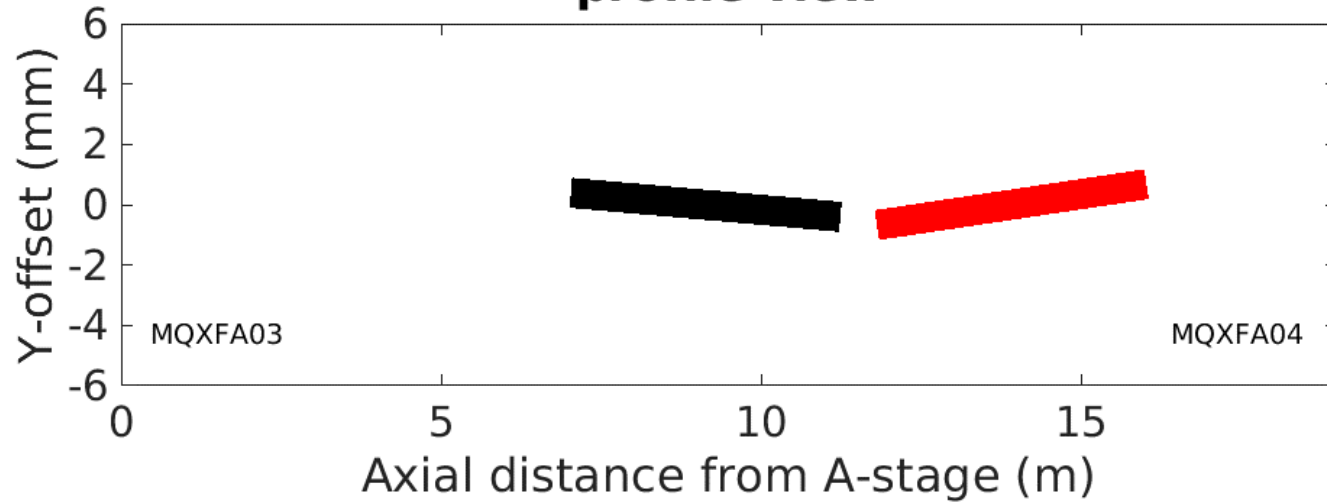

# SSW strength vs $1/\text{freq}^2$

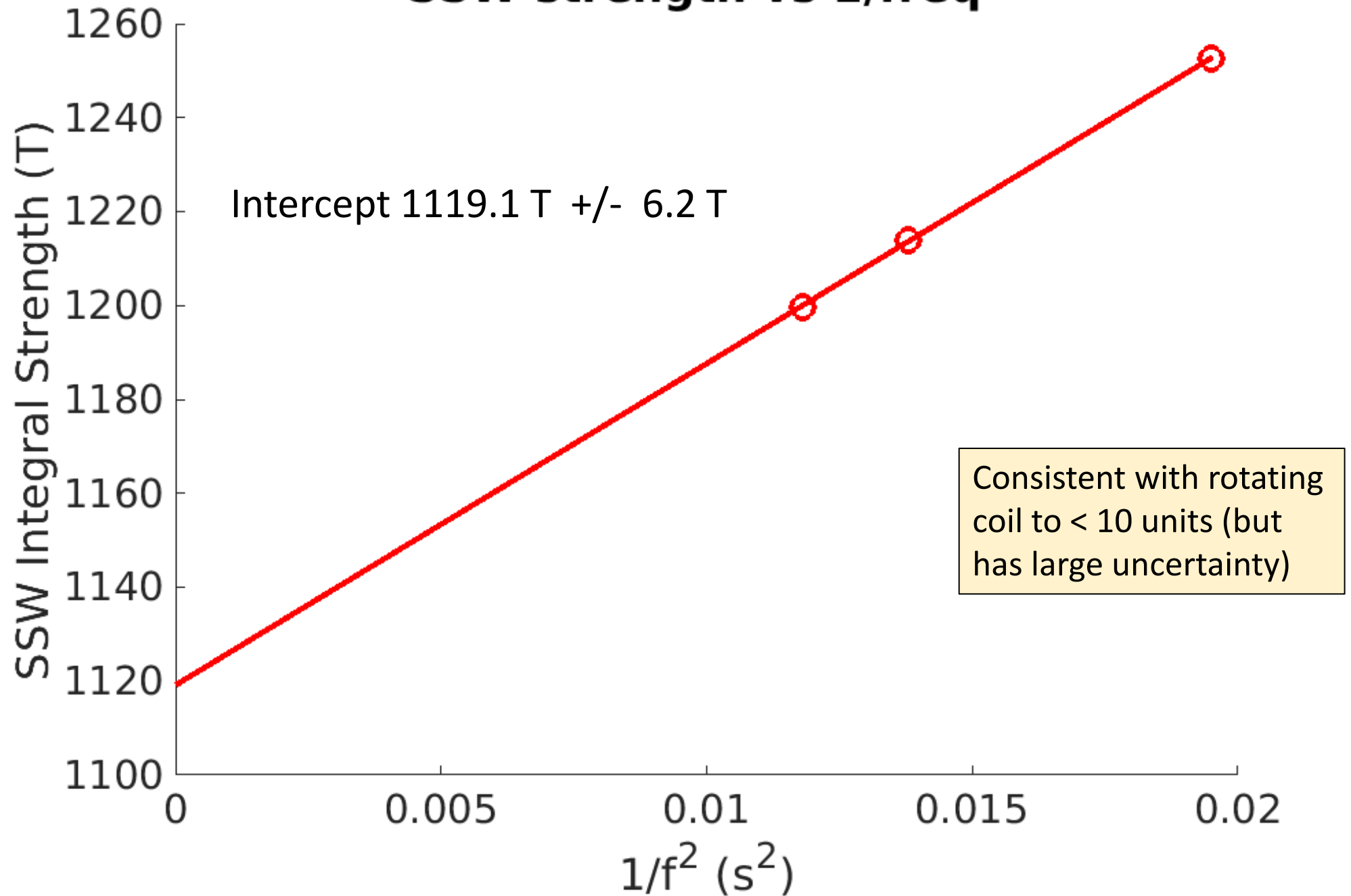

# Extensible Magnetic Measurements Software Framework fully implemented for all measurements (SSW, RC, Hall probes, etc.)

- Common UI
- Interface with power supply, LT, motion systems, data acq., etc.
- Scripting of measurement sequences

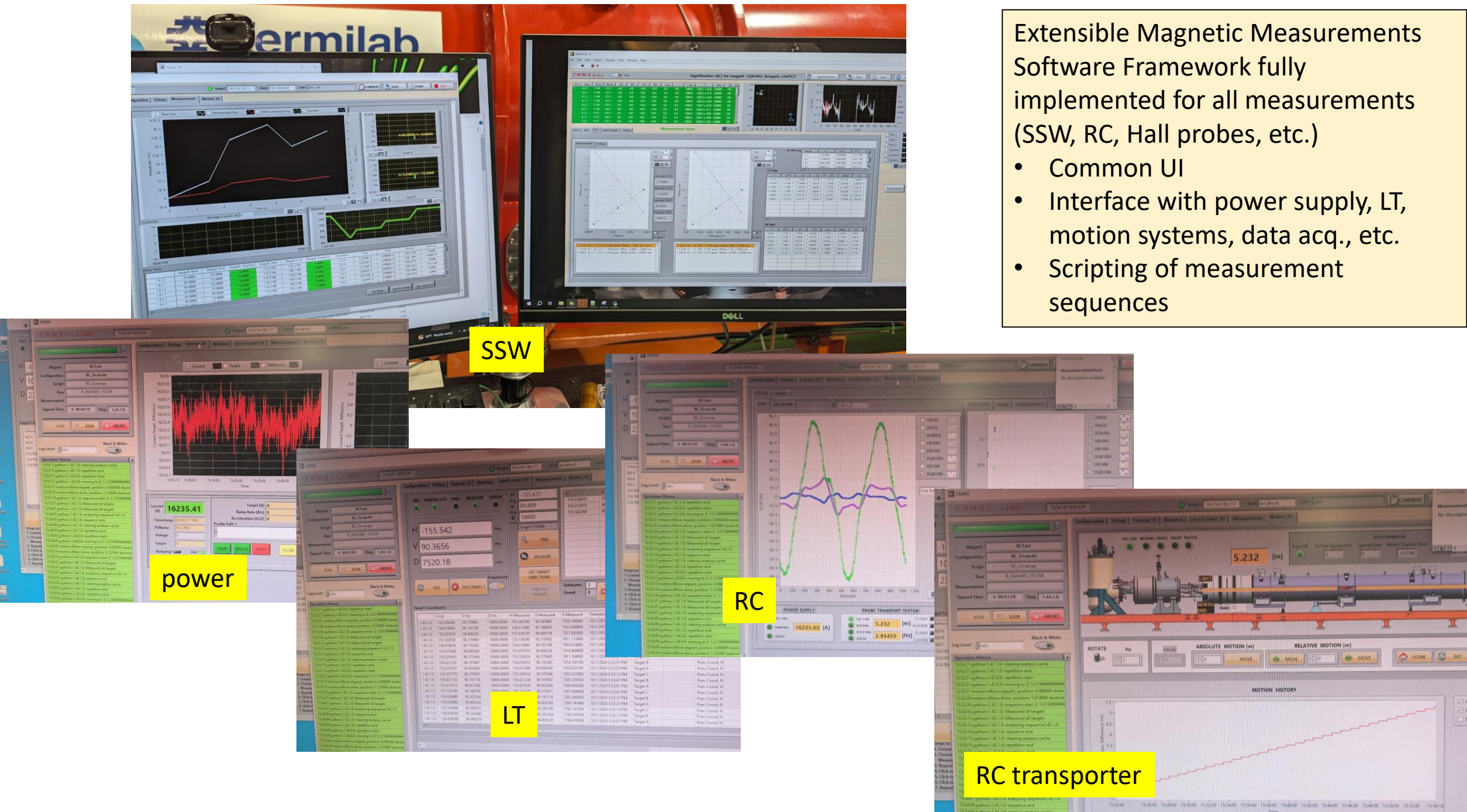

SSW

power

RC

LT

RC transporter



Magnets for Oak Ridge National Laboratory Proton Power Upgrade (PPU)

Two Proton Power Upgrade (PPU) Chicane Dipole magnets, OCA001 (“D2”) and OCB001 (“D3”), and a spare were designed, built and tested by Fermilab for the Oak Ridge National Laboratory. A combined function ‘dump septum’ magnet was similarly also part of the effort.

Detailed studies were made of the field strength and field:

- Hall probe field maps show very good agreement with model predictions throughout the large magnetic volume, with some small deviations that may be related to actual, versus assumed, magnet steel properties, or possibly due to the steel support structure. These are also used for proper placement of the D2 stripping foil.
- The integrated field strength and field quality were measured with a SSW for and meet requirements at both the 1.3 and 1.0 GeV settings.
- The septum magnet had additional measurements with a curved single-wire bundle flatcoil

Good field region  
~200 mm  
(reference radius  
100 mm)

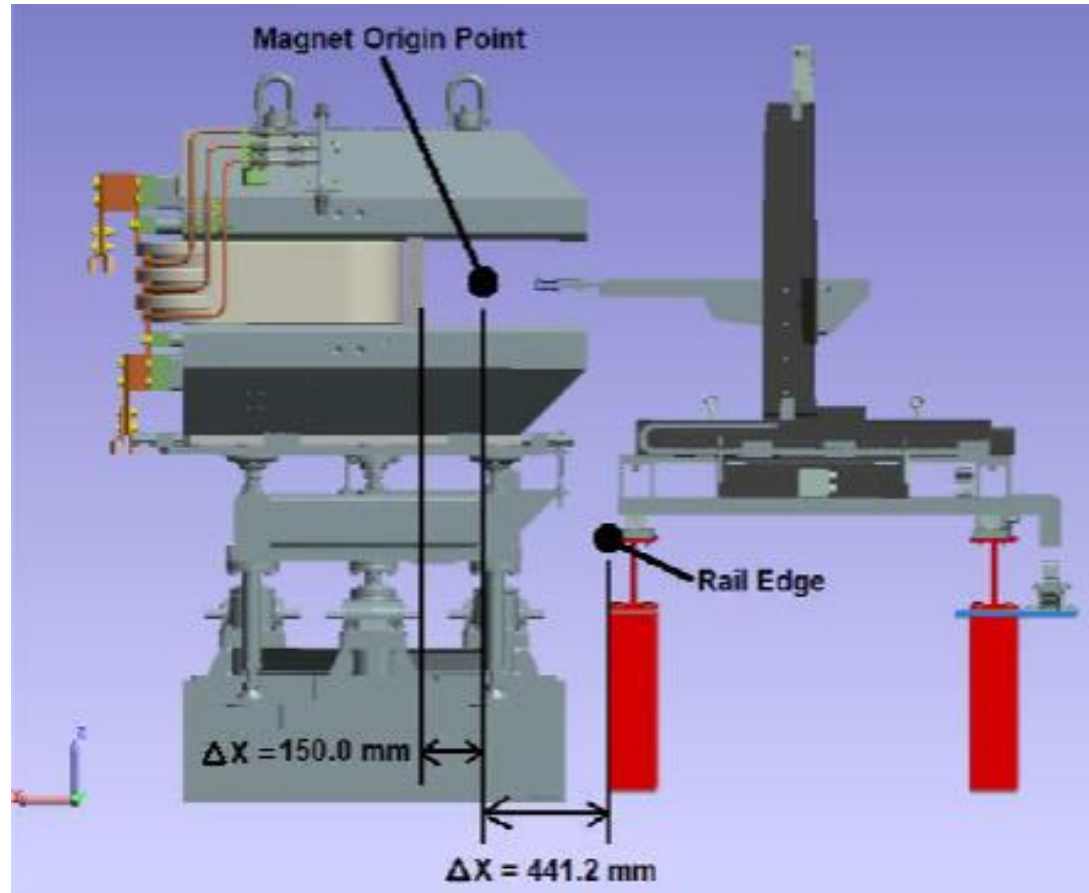

Very large magnets – had to be mounted on the floor next to our test stand (!)



### Mechanical improvements to our test stand

- New precision rails purchased and adjusted to be true at 0.05 mm level
- Two new motion stages for probes, one with two-axis and one with three-axis capabilities (Aerotech, 10 micron precision full range, load capacity of 50kg. The horizontal and vertical stages have 600 mm range, axial 1000 mm range.)
- Renishaw absolute position encoder along the entire length

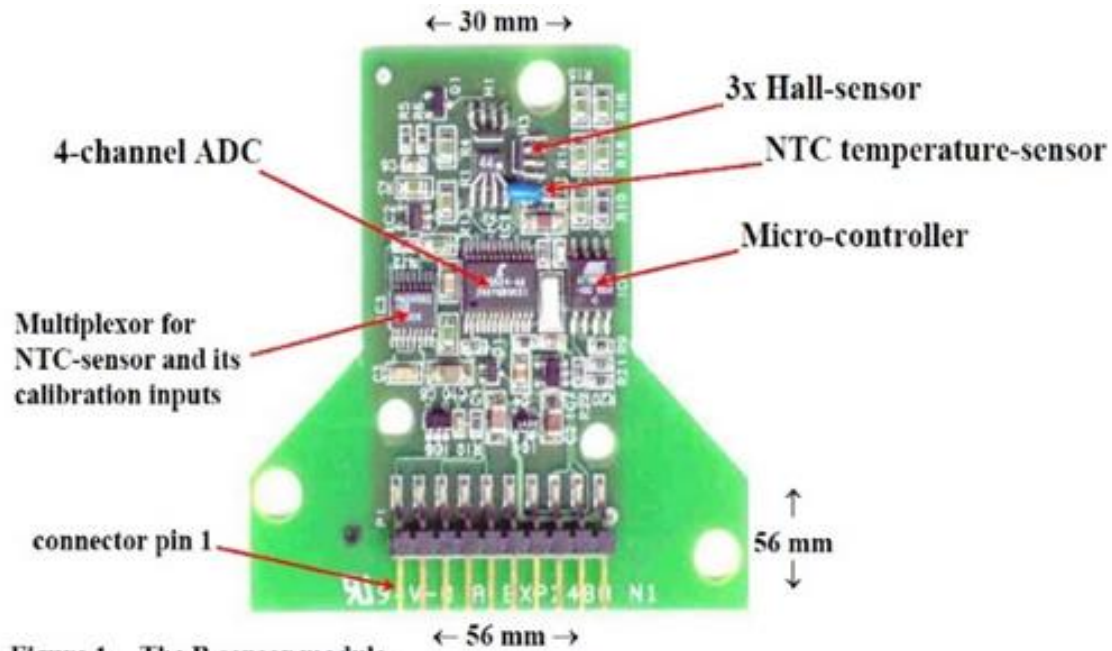

Figure 1. The B-sensor module.



A set of CERN/NIKHEF Hall probes and electronic readout system was used for the bulk of “point scan” magnetic field measurements. These have three Hall elements mounted on the face of a small glass cube (~5mm on a side) to provide a 3-D field measurement within a small volume;

The PC Board is housed in a G-10 support which has 3 metal spheres (glued into wells with epoxy) for mounting to a support structure.

Field measurements are digitized by an on-board 24-bit ADC, and the probes are calibrated by CERN to a precision  $1e-4$  of one part in 10,000 with spherical harmonic coefficients that correct for small non-orthogonality of the Hall elements (ref. F. Bergsma, previous IMMWs).



Array of 8 Hall probes for mapping the aperture



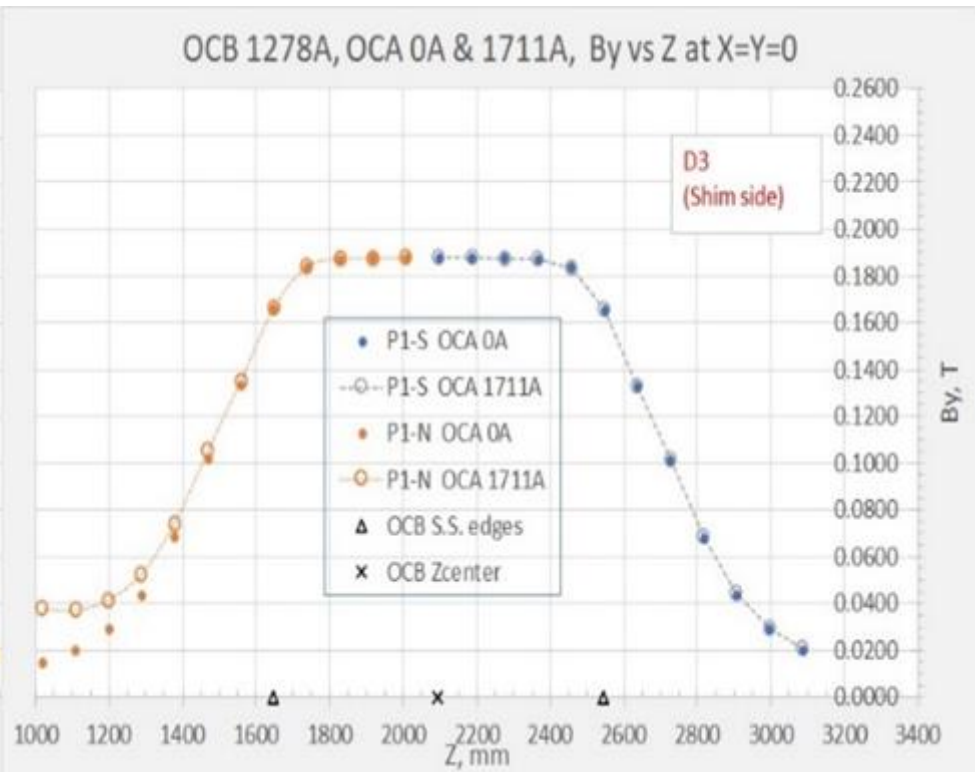
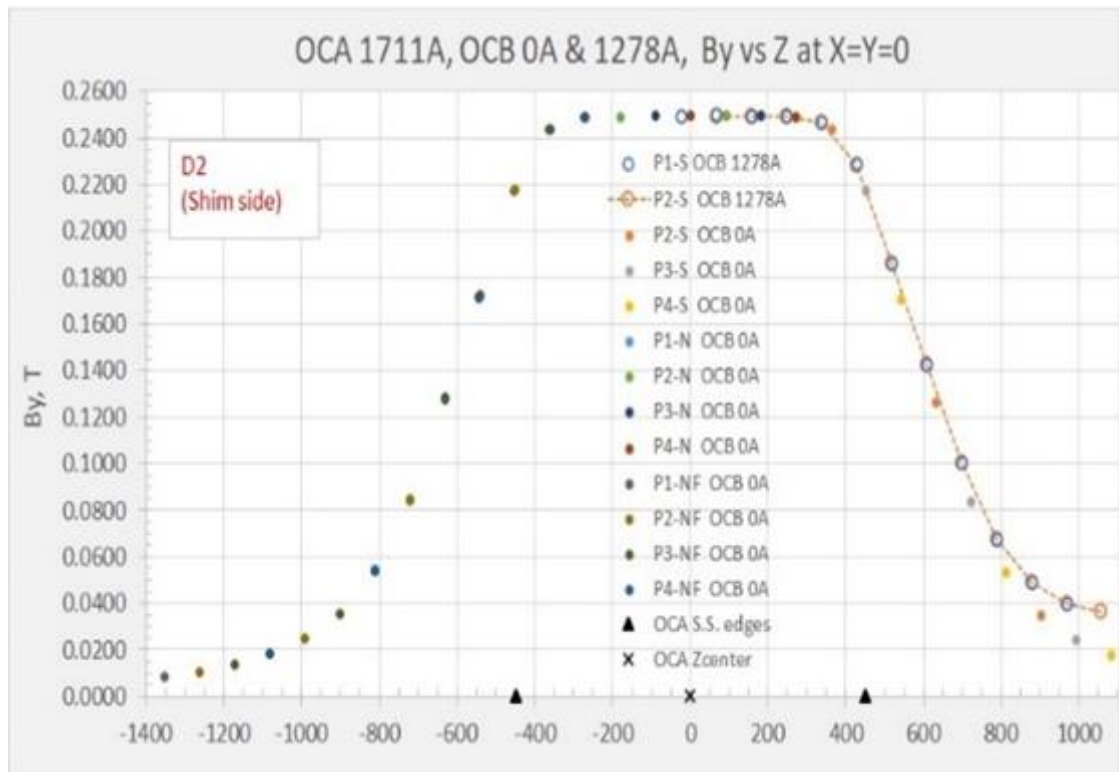

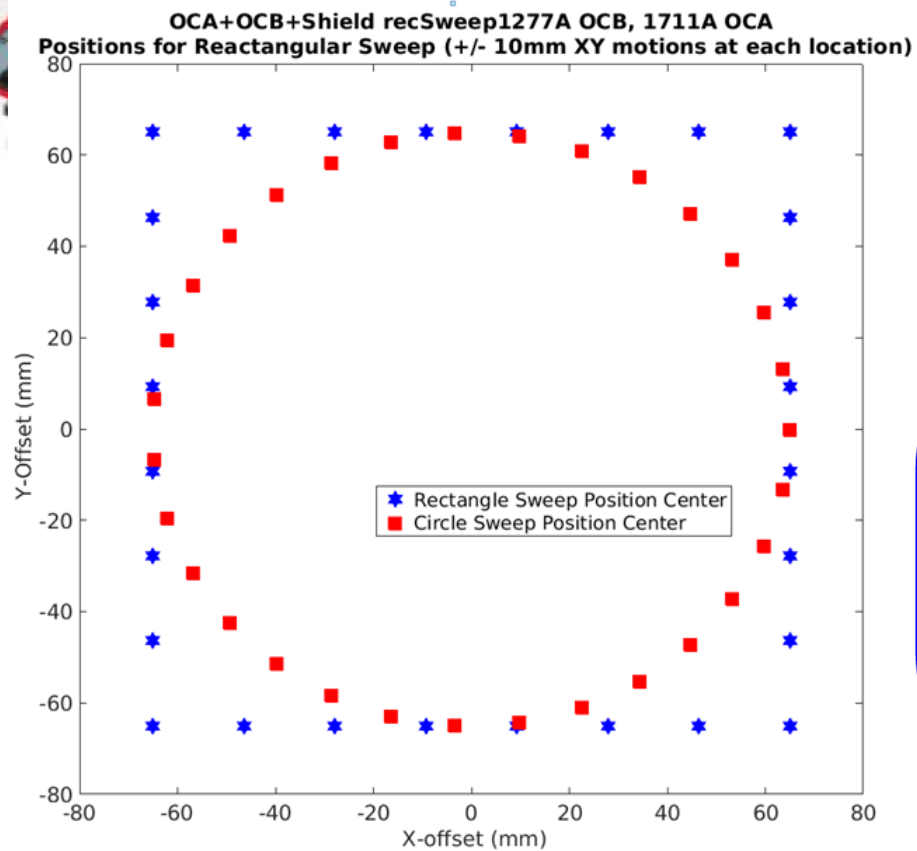
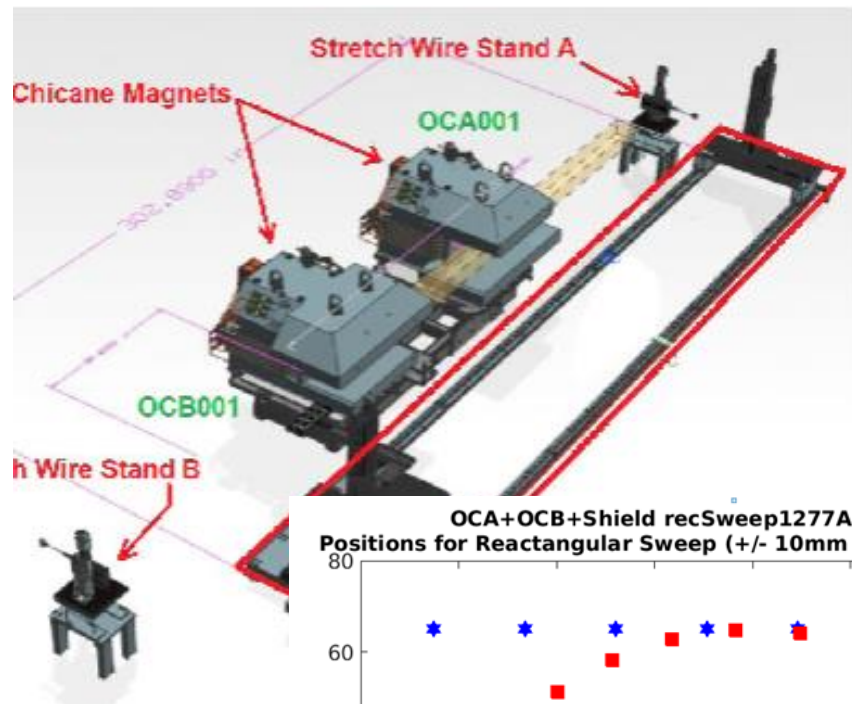

SSW stages only have ~150 mm range, but 'good field' region has reference radius of 100 mm.

To make better measurements of the harmonics reported at that radius, used a square wire pattern rather than circular (radius in the corner is about 100 mm)

Use matrix solution finding sensitivity at each position without approximations

$$\begin{pmatrix}
 (K_1(\theta_1)e^{i*1*\theta_1}) & (K_2(\theta_1)e^{i*2*\theta_1}) & (K_3(\theta_1)e^{i*3*\theta_1}) & \dots & (K_{15}(\theta_1)e^{i*15*\theta_1}) \\
 (K_1(\theta_2)e^{i*1*\theta_2}) & (K_2(\theta_2)e^{i*2*\theta_2}) & (K_3(\theta_2)e^{i*3*\theta_2}) & \dots & (K_{15}(\theta_2)e^{i*15*\theta_2}) \\
 (K_1(\theta_3)e^{i*1*\theta_3}) & (K_2(\theta_3)e^{i*2*\theta_3}) & (K_3(\theta_3)e^{i*3*\theta_3}) & \dots & (K_{15}(\theta_3)e^{i*15*\theta_3}) \\
 \vdots & \vdots & \vdots & \ddots & \vdots \\
 (K_1(\theta_{128})e^{i*1*\theta_{128}}) & (K_2(\theta_{128})e^{i*2*\theta_{128}}) & (K_3(\theta_{128})e^{i*3*\theta_{128}}) & \dots & (K_{15}(\theta_{128})e^{i*15*\theta_{128}})
 \end{pmatrix}
 \begin{pmatrix}
 C_1 \\
 C_2 \\
 C_3 \\
 \vdots \\
 C_{15}
 \end{pmatrix}
 =
 \begin{pmatrix}
 \varphi_1 \\
 \varphi_2 \\
 \varphi_3 \\
 \vdots \\
 \varphi_{128}
 \end{pmatrix}$$



# SSW Measurements around perimeter (reported at reference radius R=100 mm)

PPUSSW\_R\_20230329\_081204\_DC\_StrengthAngle

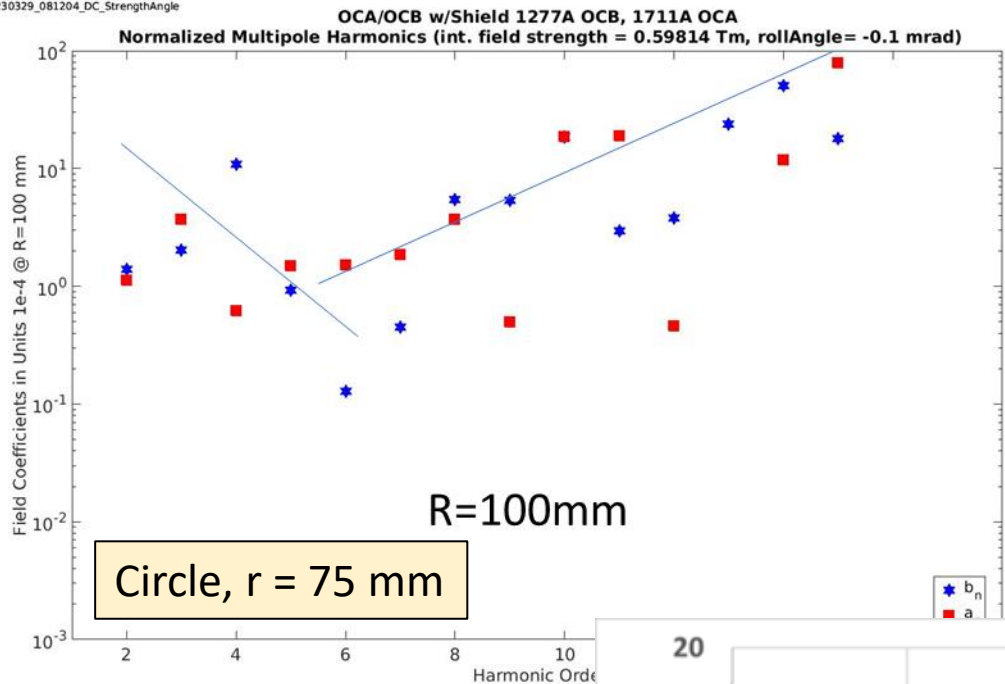

PPUSSW\_R\_20230406\_114405\_DC\_StrengthAngle

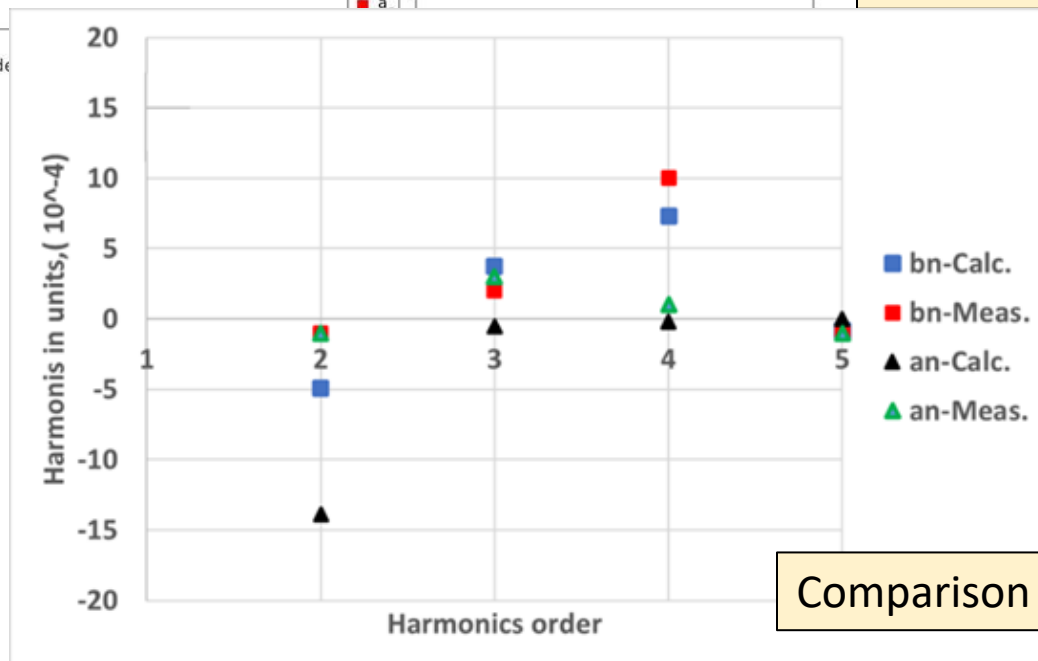
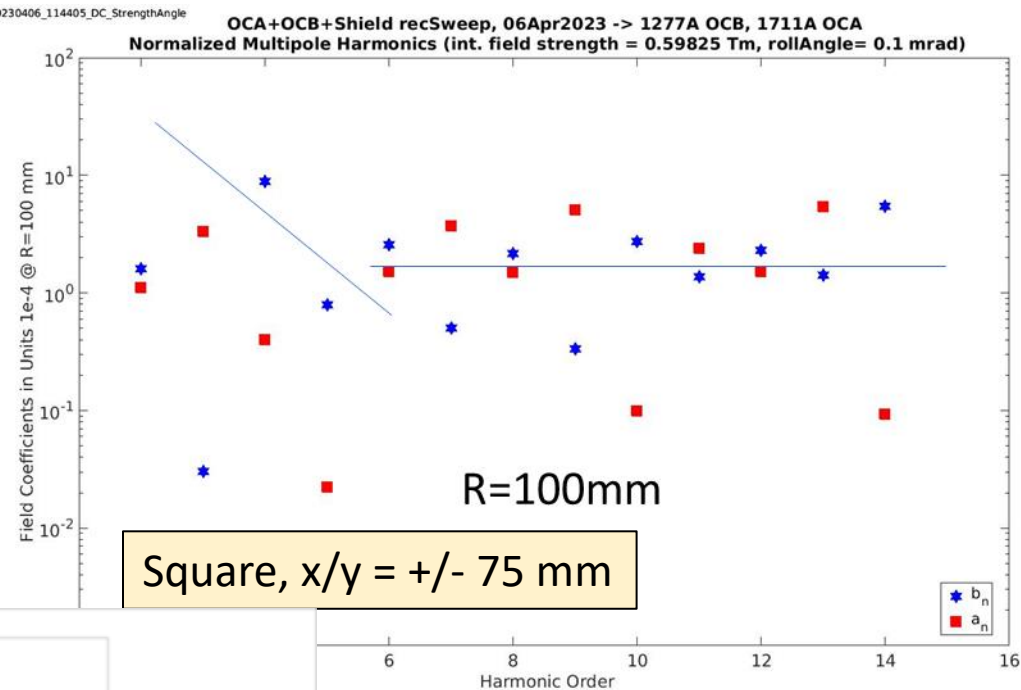

Comparison to calculation

## PPU Dump Septum

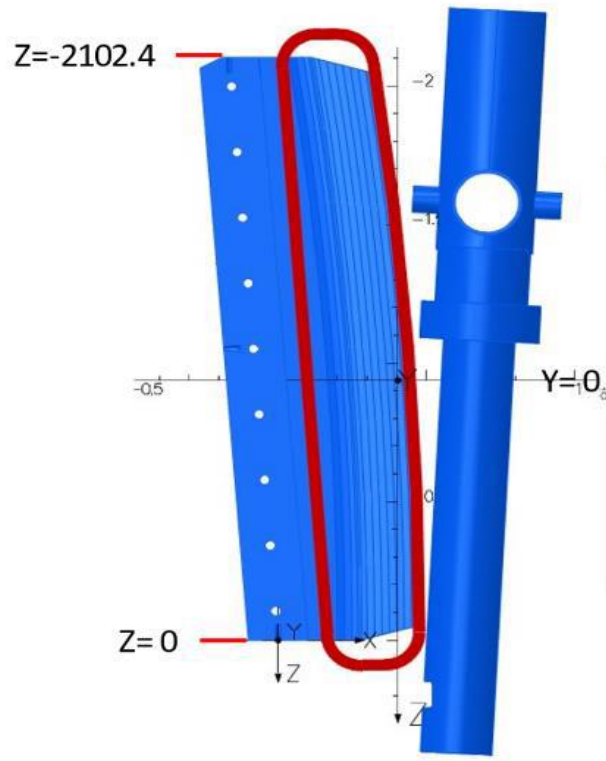

Two beams enter the magnet (or go into the 'zero field' septum) on different trajectories, but are bent so they are 'dumped' to the same the same downstream target.

Need to accurately measure the integrated field along the two different curved paths.

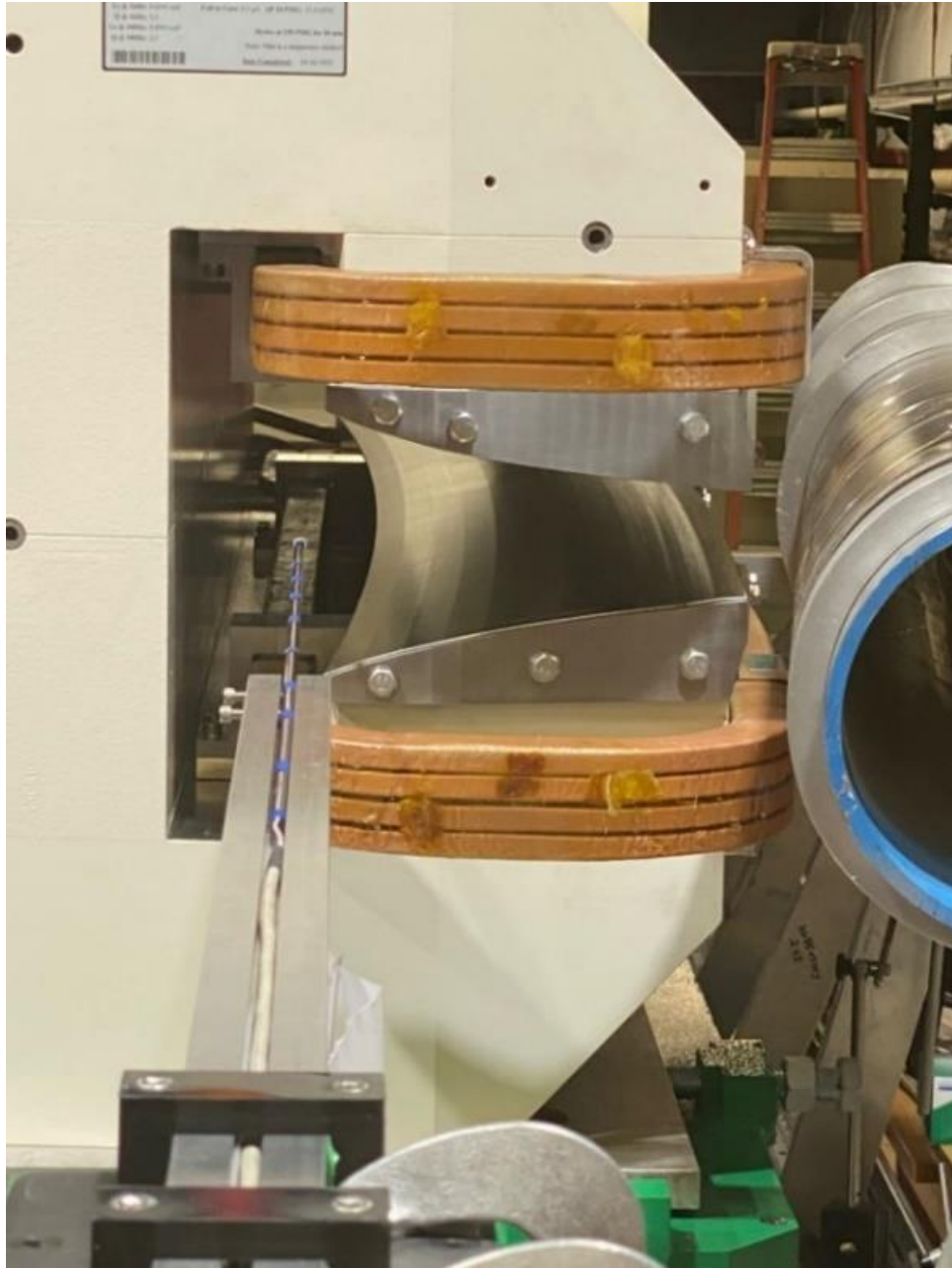

View of curved poles and shielded septum (during Hall probe end field measurements)



SSW measurements were made and compared to calculation of straight line integrals

SSW Measurements vs Simulation			Simulated	Measured	
Trajectory chord	Enter [x,z] (m)	Exit [x,z] (m)	Integral By, (T-m)	Integral By, (T-m)	% diff
H <sup>0</sup>	[0.475, 0.655]	[0.179, -2.724]	1.0992	1.0980	-0.11
H <sup>-</sup>	[0.355, 0.655]	[0.079, -2.724]	0.8030	0.8021	-0.11



Measurements in 'field free' septum region

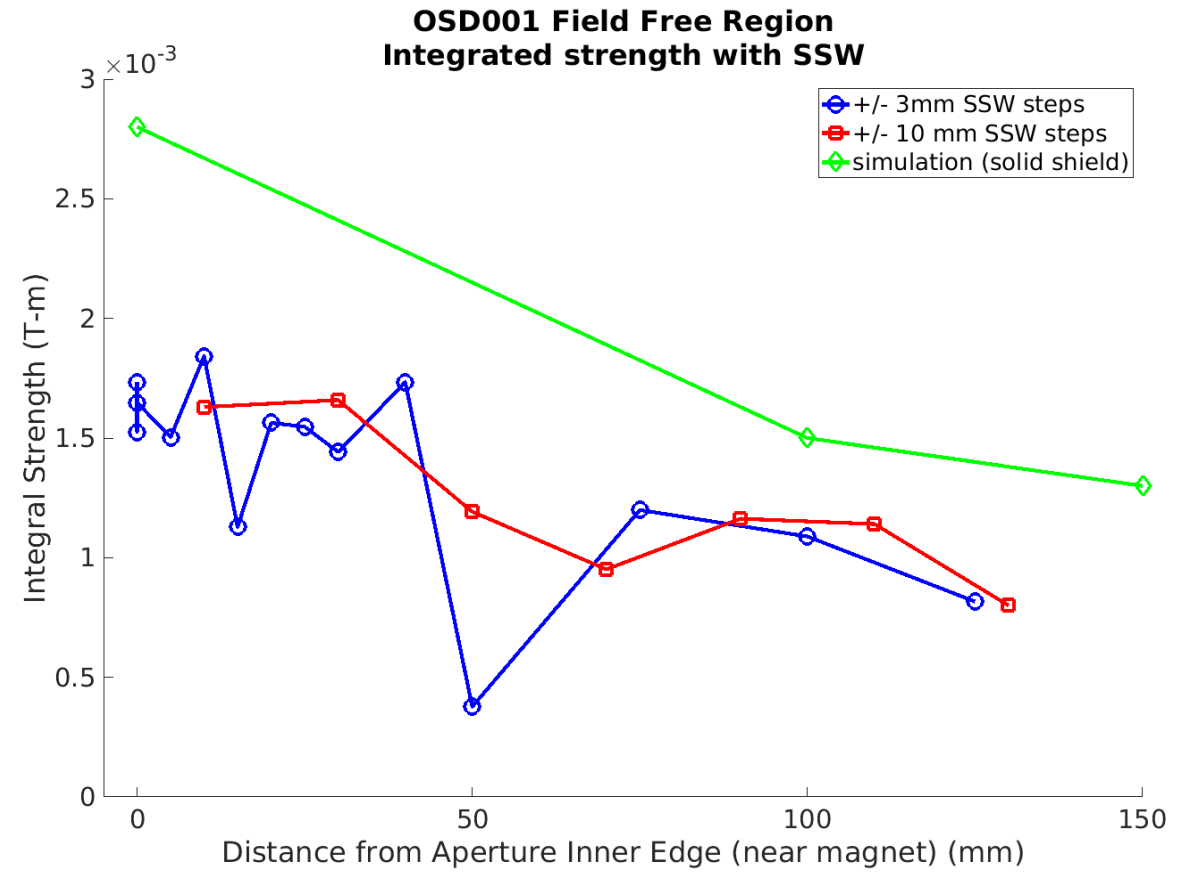

# Measurements on the beam trajectories

A single wire bundle flatcoil was fabricated to measure along the two nominal trajectories.

The wire bundle consists of 12 insulated wires twisted together, but connected in series (so as to multiply the signal), within a jacket of 2.4mm outer diameter (the return loop of each wire bundle lying stationary along the back-leg of the magnet).

The grooves are machined into a 3.35 m-long (132"-long) carbon fiber plate, which is supported by the stages at its ends, and by roller assemblies within the magnet.

The change in flux induced in each wire bundle loop stems from the precise translation of the flatcoil in the magnetic field. Since this motion is controlled using the SSW stages, which have 1 micron motion accuracy, a measurement of the integrated voltage during movement yields a high-accuracy measurement of the dipole and gradient field integrals.



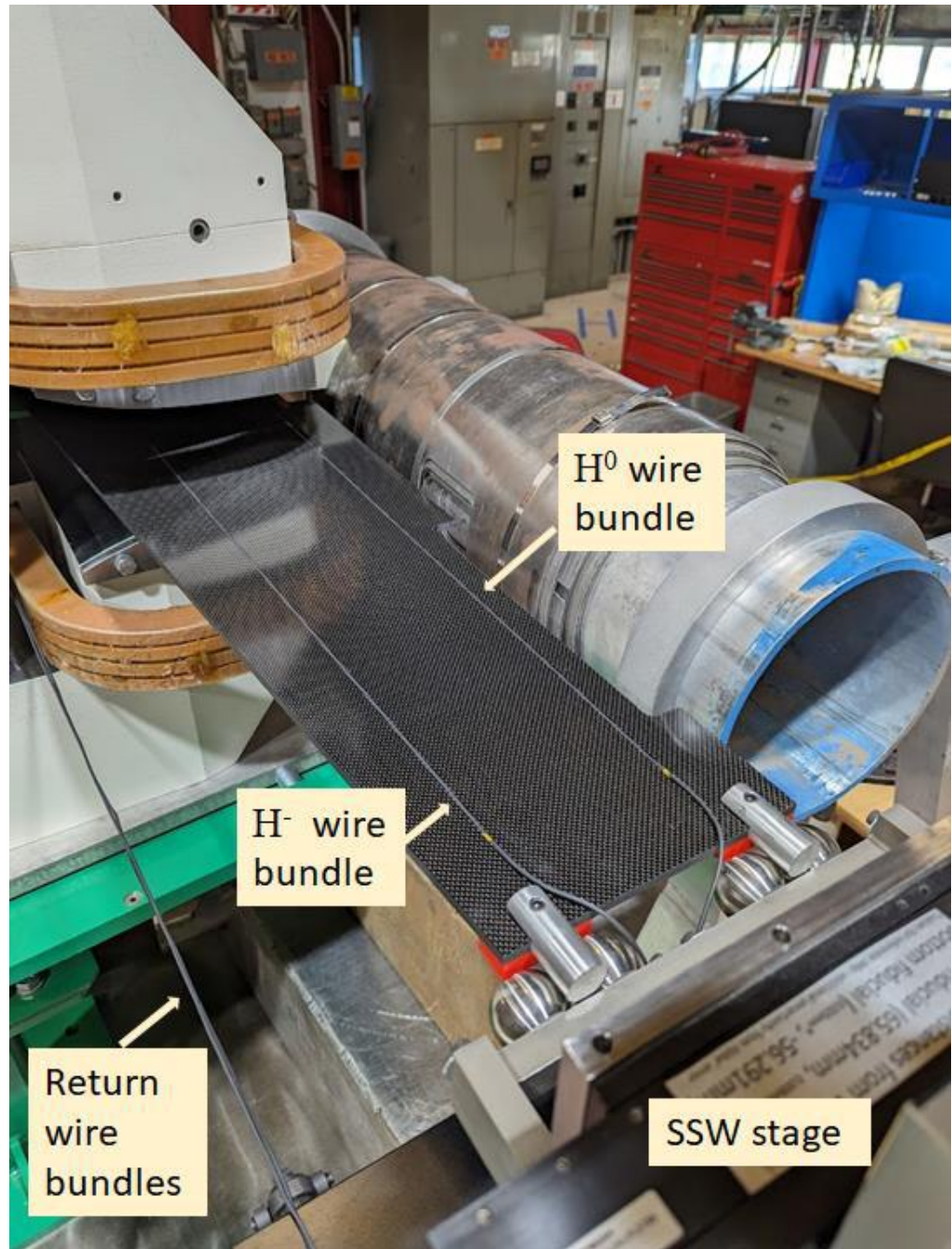



Flatcoil Trajectories	Simulated Integral By, (T-m)	Measured Integral By, (T-m)	s.d. (T-m)	Meas-Siml % diff
H <sup>0</sup>	1.2390	1.2371	0.0003	-0.15
H <sup>-</sup>	0.8528	0.8527	0.0003	-0.01

Combined Function Magnets for Fermilab's Proton Improvement Plan (PIP-II)

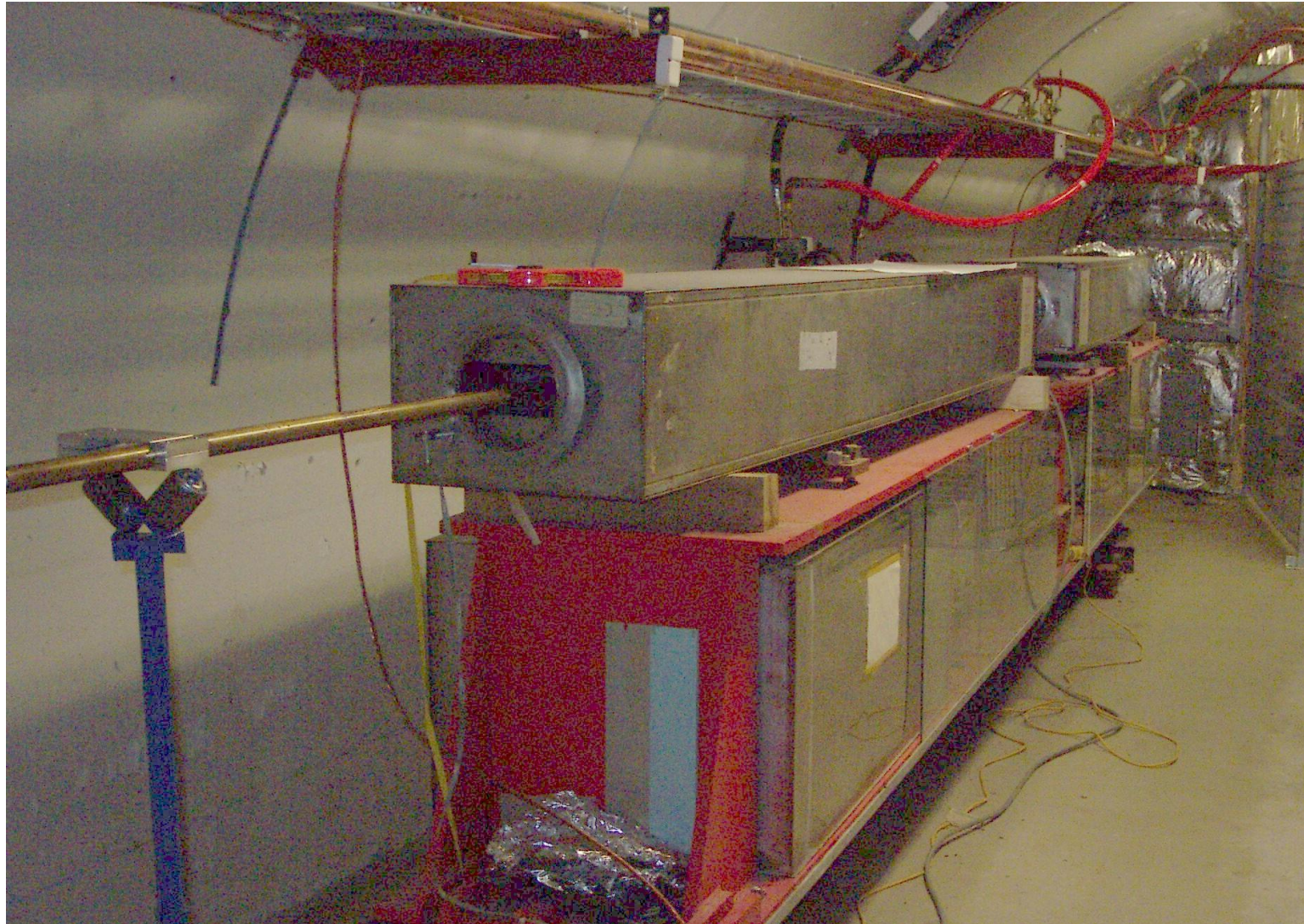

15 Hz Booster magnet (combine function dipole/quad) will be upgraded to 20Hz and additional magnets fabricated

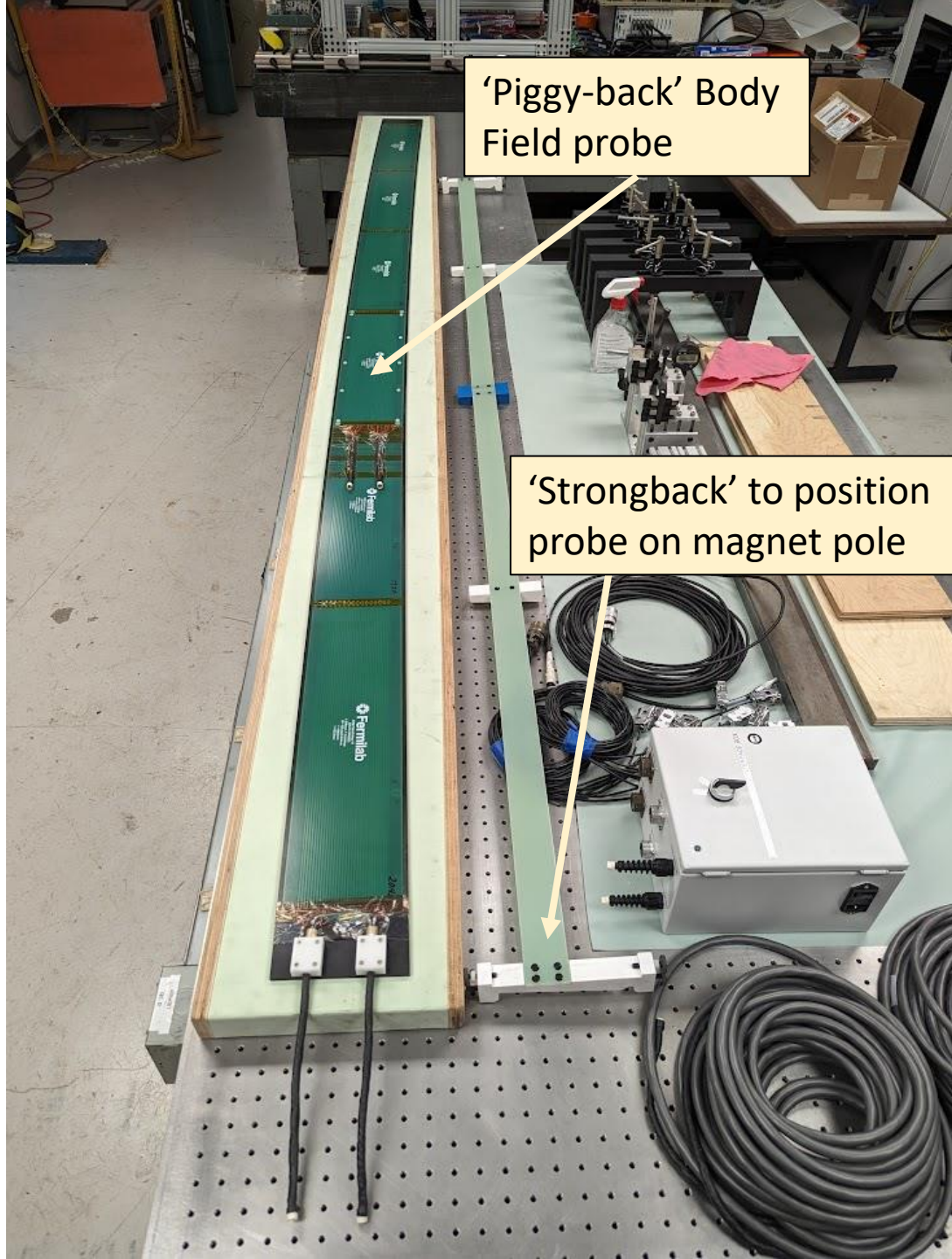

'Piggy-back' Body  
Field probe

'Strongback' to position  
probe on magnet pole

Probe to measure integral AC fields

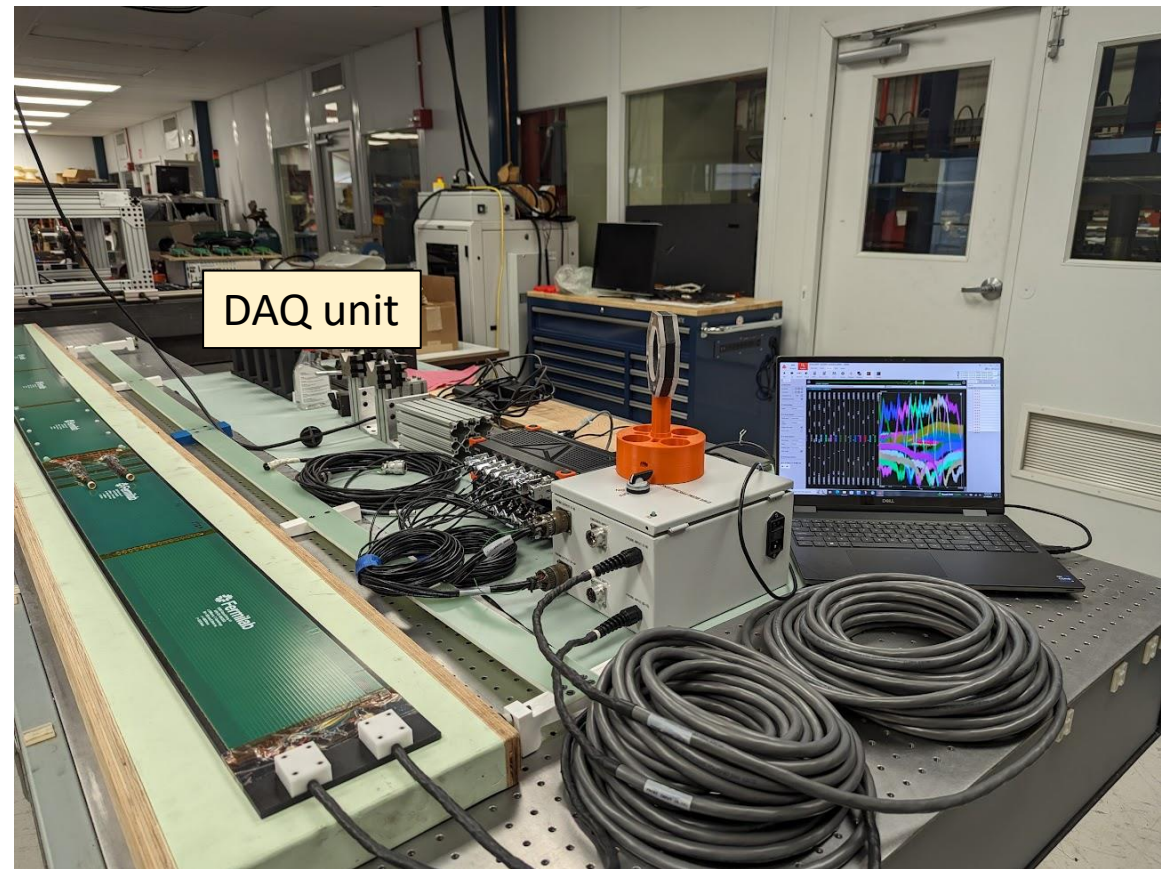

DAQ unit

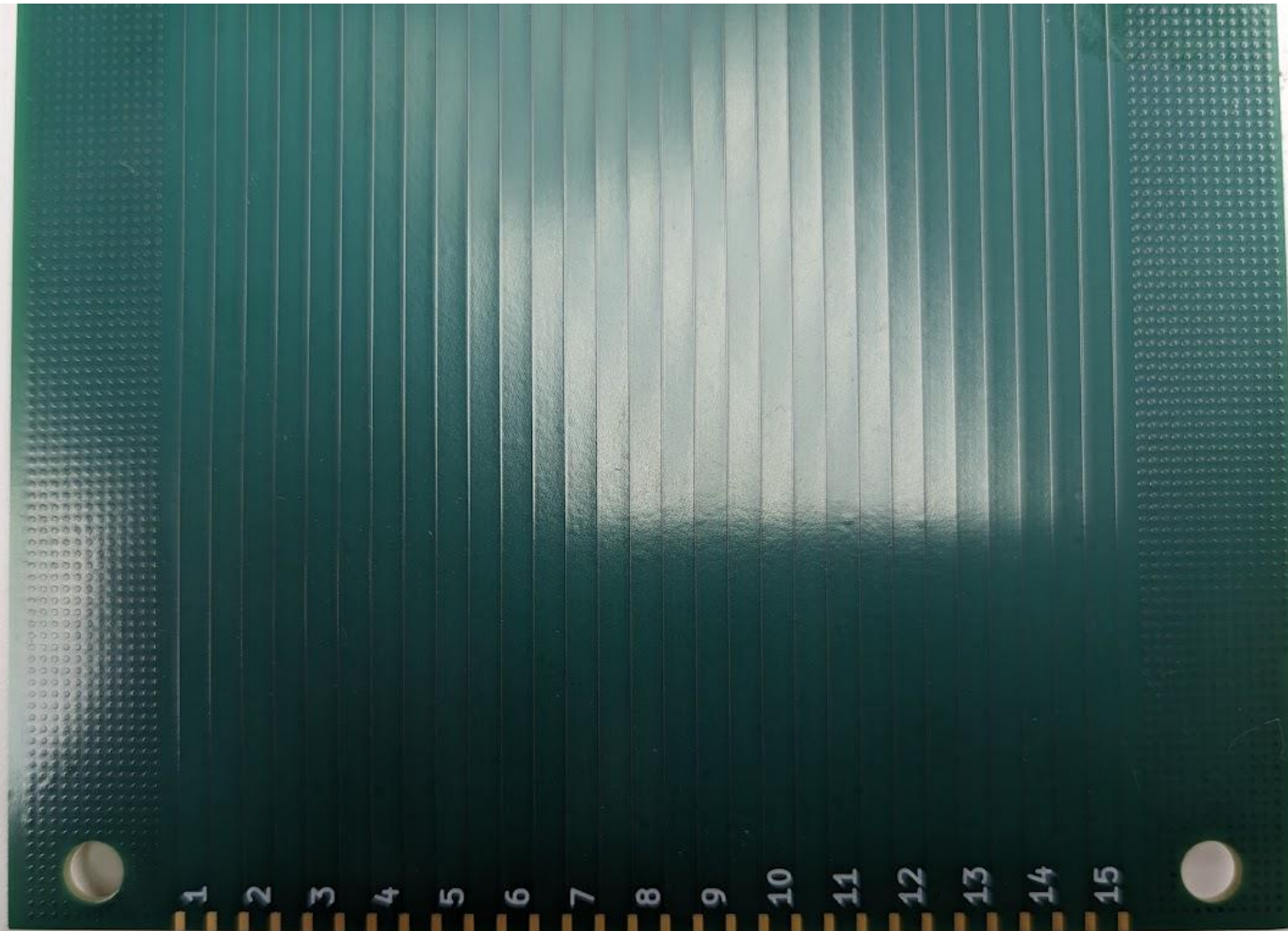

Probe is curved to match the D magnet radius.

15 loops, 3.5mm wide each, separated by 7mm, total width = 101.5 mm



Probe situated within magnet. Note that probe can slide +/- 3.5mm to stops on strongback so that loops can be cross-calibrated at same horizontal position in magnet.

# BGM AC magMeas probe loop width variation

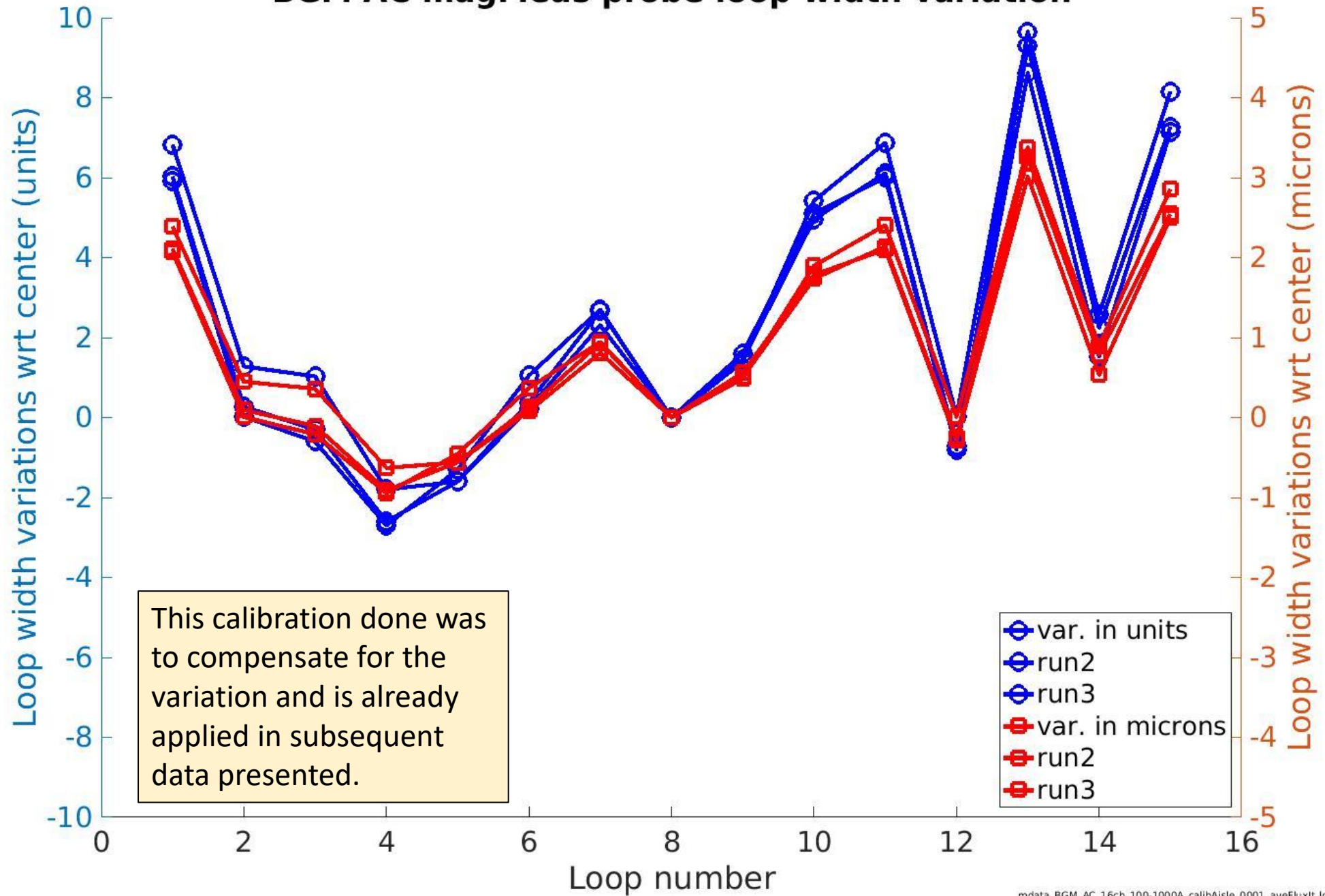

### Integral field residual 1055 A

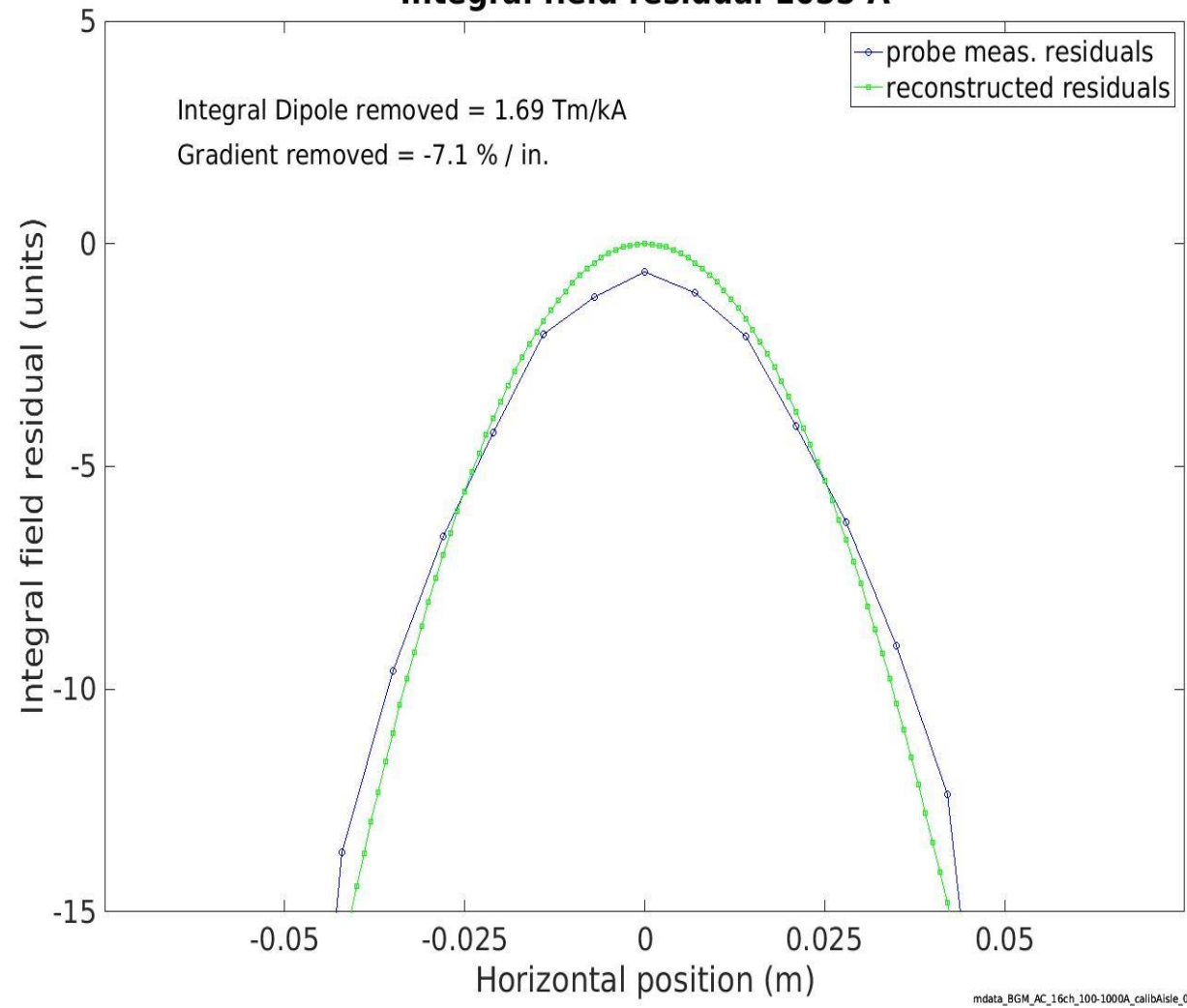

Note that current cycles from ~110 A to ~1055 A



# Normalized Field residual vs Current

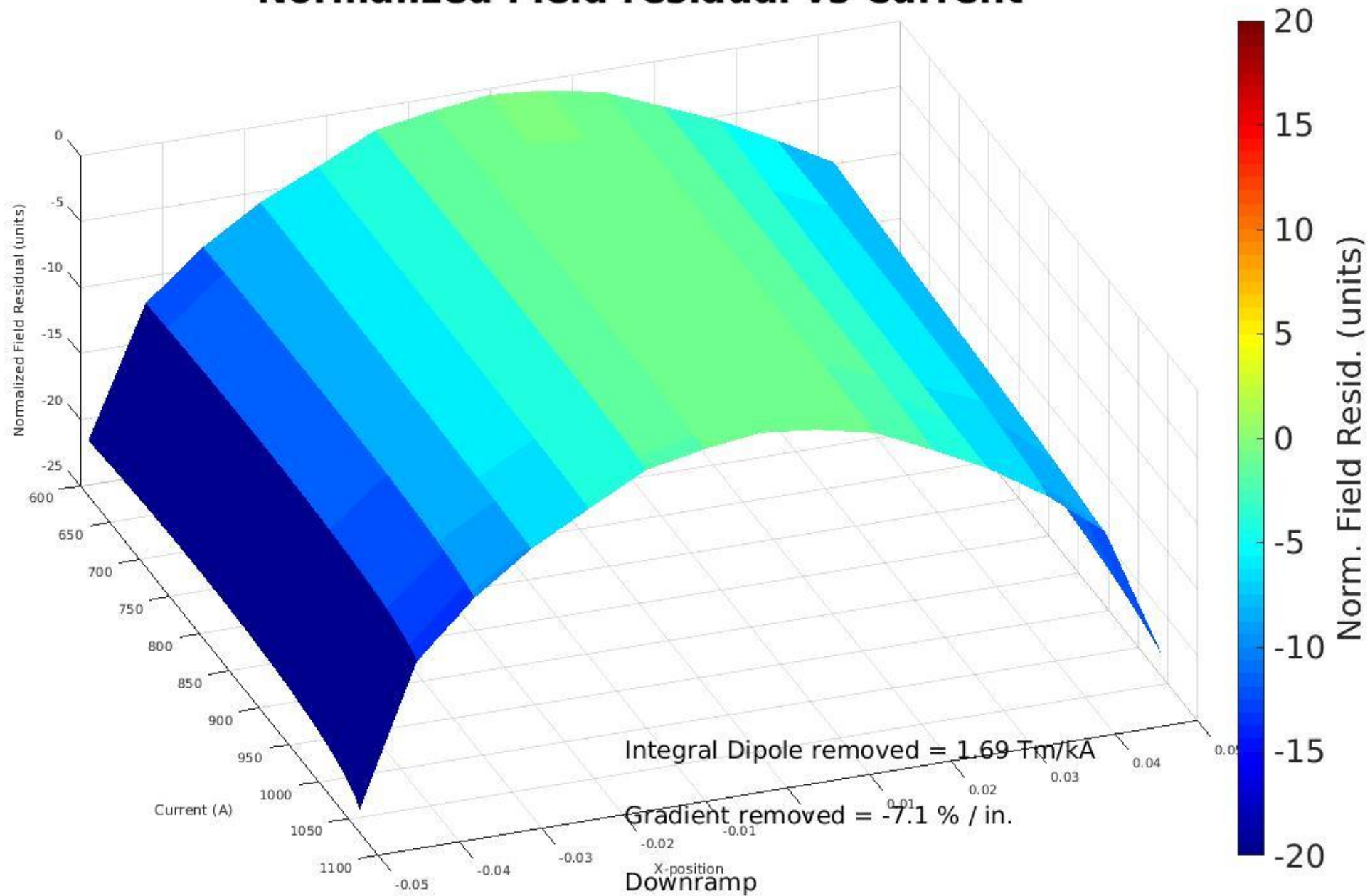

# Normalized Differential Gradient vs Current

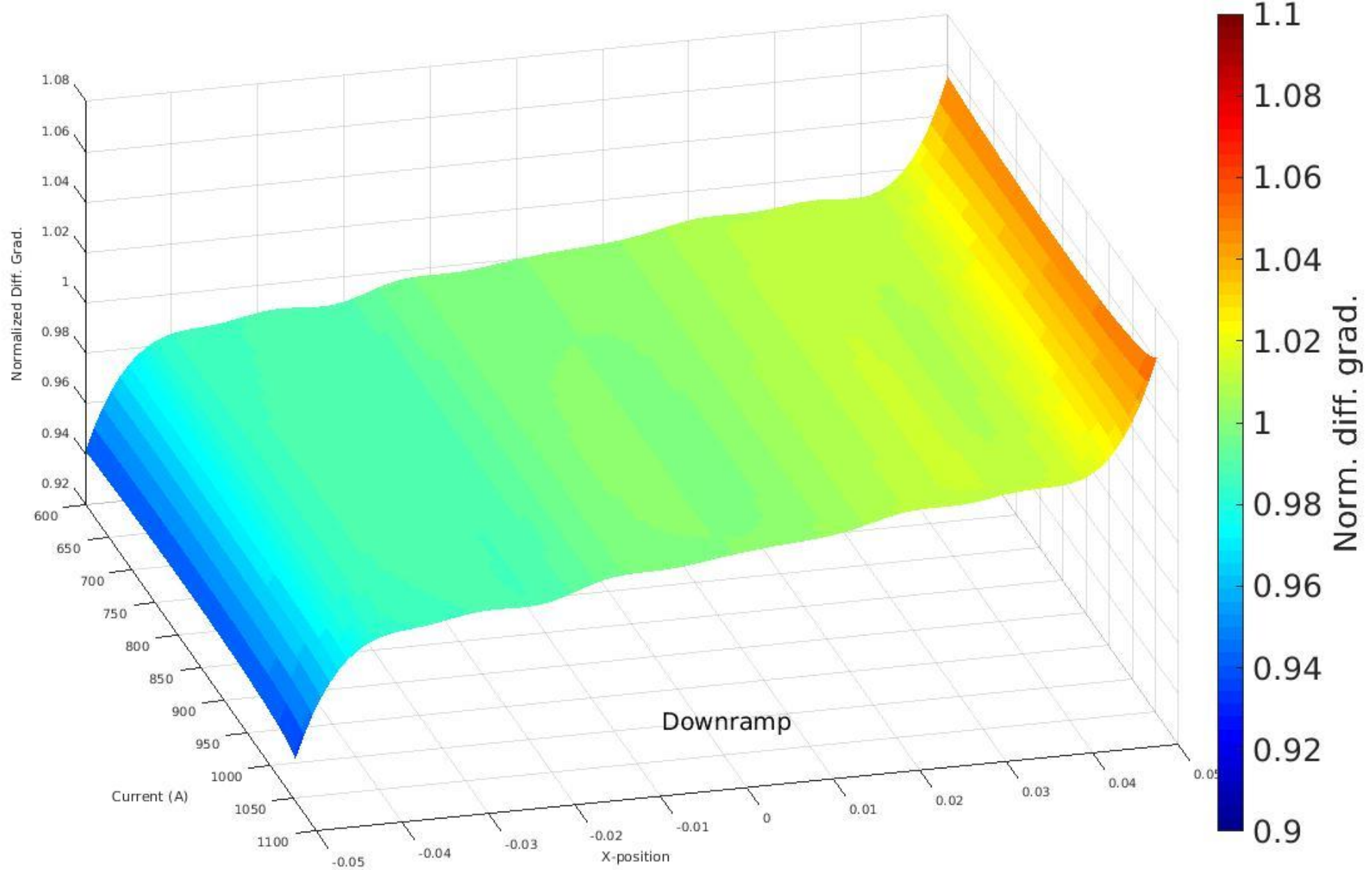

Thanks for your attention