

# Magnets for SOLEIL II

C. Kitegi, F. Marteau, J. Chavanne, M-E Couprie, S. M. Khan, V. Pinty, M. Valleau  
on behalf of SOLEIL II Project Team

1. 80 pm.rad / 2.75 GeV / 354 m.
2. 20 straight sections ( 2 of ~8 m, 4 of 4.2m, 4 of 3.7m, 2 of 3.5m and 8 of ~3.1m).
3. Large photon spectrum (far IR to hard X-rays).
4. Non-standard MBA lattice: 12 x 7BA + 8 x 4BA with symmetry 1.
5. NEG coated very small vacuum chamber diameter = 10 mm.
6. Extensive use of permanent magnets.
7. Miniaturization.
8. Off-axis injection.
9. High performance Multipole Injection Kicker (MIK).
10. Wide prototyping program (inc. 6 magnets)
11. Energy Savings.

## Key features

### 7BA cell

- Dipole in red
- Reverse Bend in magenta
- Quadrupole in blue,
- Sextupole in yellow
- Octupole in cyan

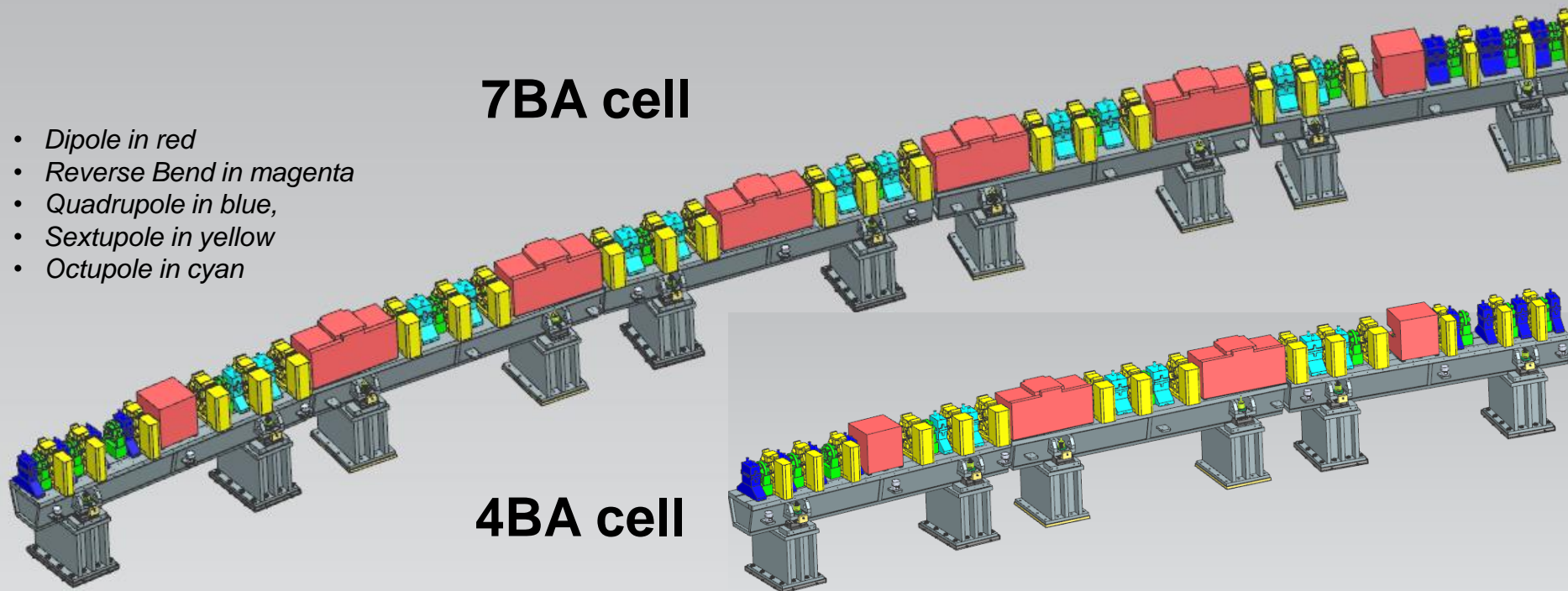

### 4BA cell

- **Number of magnets**

- Total number: **1277**

- Number of types: **41** types + 8 x Superbend with 3T, 1.7T, 1.2T peak field

## 1. PM design

- Dipole with transverse gradient
- Quadrupole
- Reverse Bend

SmCo magnets and low carbon steel (except the 3T pole made of Fe-Co alloy)

## 2. EM design

- Normal Quadrupolar Corrector
- Sextupole
- Octupole

- Magnet doublets (sextupole/normal quadrupole corrector, sextupole/octupole)

- Harmonics : under discussion and iterations

- Magnetic measurements: usual methods such as Stretched wire and Hall probe

		Gap [mm]	Dev[mrad]	Lmag[mm]	B[T]	B'[T/m]	Nbr	Tot		
Permanent magnet technology	Short dipoles							40		
	DNC1	23	42.2206	430	0.893	17.7	22			
	DNC2	23	40.0925	430	0.851	17.7	16			
	DNC3	23	41.433	430	0.893	17.7	1			
	DNC4	23	48.4646	430	0.895	17.7	1			
	Long dipoles							76		
	DNL1	22	68.8573	947	0.551/1.2	21.58	58			
	DNL2	22	65.3867	947	0.551/1.2	21.58	16			
	DNL3	22	69.0675	947	0.551/1.2	21.58	1			
	DNL4	22	68.5013	947	0.551/1.2	21.58	1			
	Long ReverseBends							152		
	DIL1	21	-3.4407	136.23	-0.197	83	120			
	DIL2	21	-3.2673	136.23	-0.188	83	32			
	Short ReverseBends							40		
	DIC1	18	-0.8107	118.89	-0.092	104	24			
	DIC2	18	-0.7699	118.89	-0.088	104	16			
	Chicanes							3		
	CHIC2		-12.55	200	-0.58	0	1			
	CHIC3		19.05	200	0.87	0	1			
CHIC4		-11.89	100	-1.09	0	1				
Quadrupoles QF and QD		16		67 to 100		120	128	162		
		21		137 to 192		80	12			
		23		87.5 to 130		75	22			
Electromagnet technology		Bore diam. [mm]	Gap [mm]	Yoke Length[mm]		Integrated strength		412		
	Sextupoles (plus Horiz and Vert. Correctors)		16	6.2	60		550 T/m		80	
			16	7	60		550 T/m		16	
			21	6.2	60		350 T/m		10	
			21	7	60		350 T/m		4	
			21	10	60		350 T/m		14	
			16	6.2	80		680 T/m		98	
			16	7	80		680 T/m		74	
			16	7.5	80		680 T/m		20	
	Octupoles (plus Norm. and Skew Quadrupole Correctors)		19		60		3300 T/m <sup>2</sup>		142	
			21		60		3300 T/m <sup>2</sup>		20	
	Normal quadrupole correctors		19	7	24		1 T		225	230
			22	10	29		1 T		5	
							total	1277		



Besides undulator, PM Dipole and quadrupole magnet already built a SOLEIL

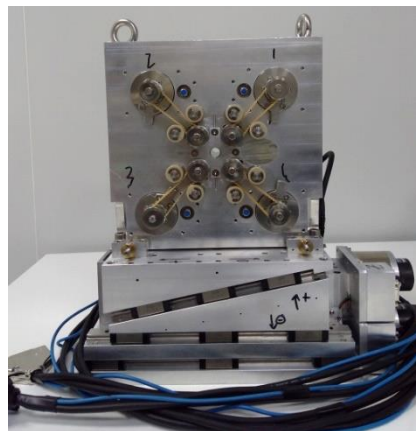
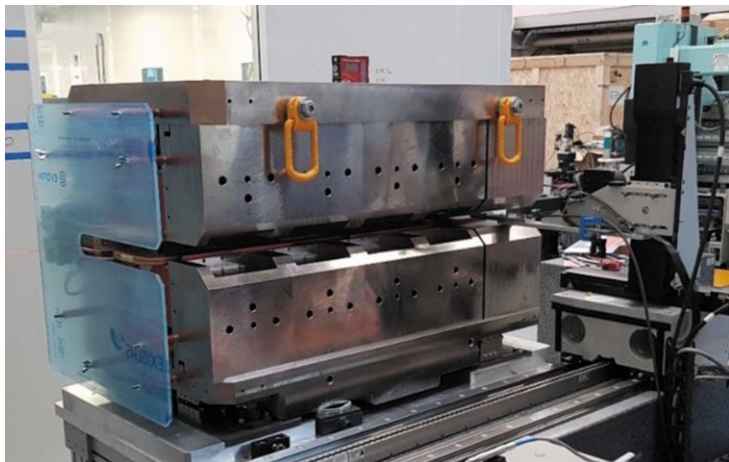

F. Marteau and *al.* Appl.Phys.Lett. 111 (2017) 25, 253503.

P. Brunelle and *al.* , « Development of a custom-made 2.8T permanent-magnet dipole photon source for the ROCK beamline at SOLEIL. » J. Synchrotron Rad. 30, p.695-707.

P. N'gotta, G. Le Bec, J. Chavanne  
*Phys.Rev.ST Accel.Beams* 19 (2016) 122401

- For SOLEIL II quadrupole, geometry proposed by ESRF is preferred

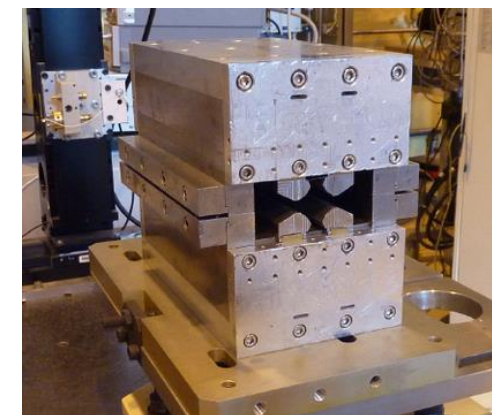

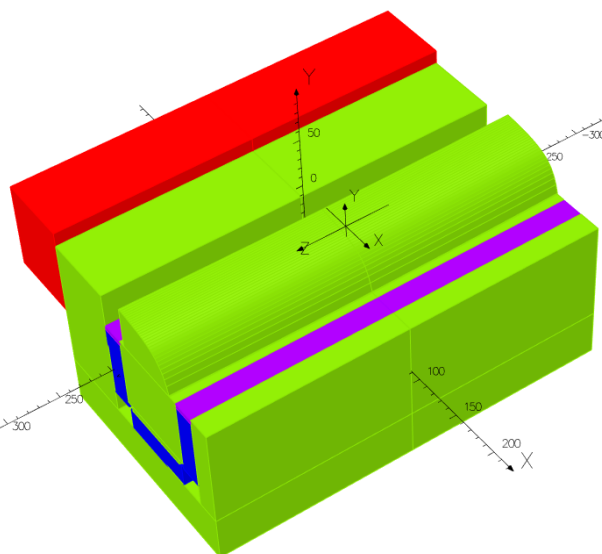

Short dipole

Low Carbone Steel in green  
 Moving Yoke in red (MY)  
 ThermoShim in purple  
 PM in blue

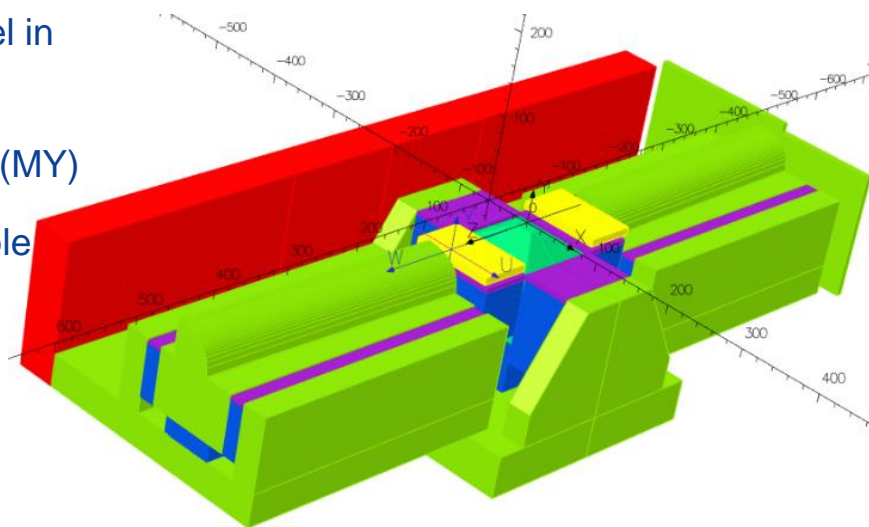

Long dipole

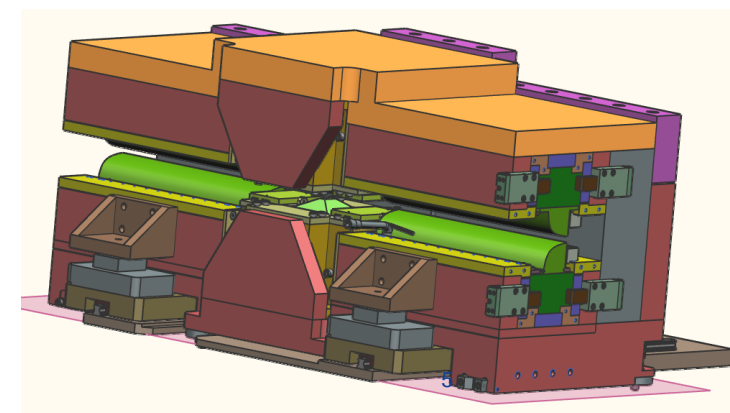
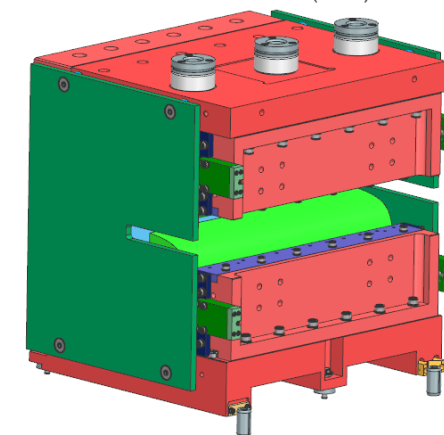
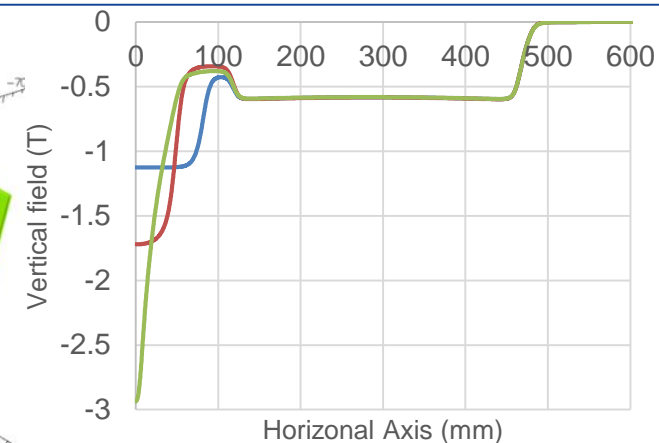

Details presented at Permalics [https://indico.cells.es/event/1229/contributions/2077/attachments/1458/2787/perm\\_soleil.pdf](https://indico.cells.es/event/1229/contributions/2077/attachments/1458/2787/perm_soleil.pdf)

	1.2 T	Bn (Unit) @ 5mm	1.7 T	Bn (Unit) @ 5mm	3 T	Bn (Unit) @ 5mm
B_Integral	-0.6253 (T.m)	10000.0	-0.627 (T.m)	10000.0	-0.627(T.m)	10000.0
G_Integral	15.301 (T)	-1223.5	15.380 (T)	-1225.9	15.320 (T)	-1222.1
S_Integral	-39.125 (T/m)	15.6	-20.3 (T/m)	8.1	-129.56 (T/m)	51.7
O_integral	-6054 (T/m <sup>2</sup> )	12.1	3962(T/m <sup>2</sup> )	-7.9	-5437 (T/m <sup>2</sup> )	10.8

A long dipole with a 3T central pole and a short dipole are prototyped

- Magnet blocks delivered In October 2024
- Mechanical parts of the yoke to be delivered in December 2024
- Assembly to be done at SOLEIL in January 2024



- Systematic octupolar component detrimental to the beam dynamics
- Unsuccessful attempt to correct the octupolar component by enlarging the width of the pole
- Design ala PETRA-IV proposed for the DQ part of the DNL

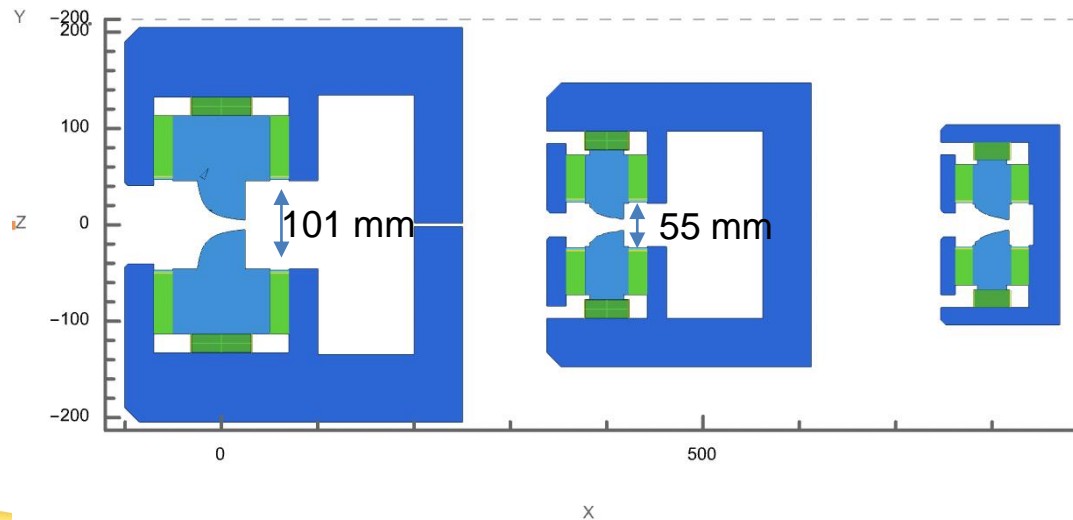

- 2D model
- narrower pole width
- Decoupled iron yoke (control residual sextupole term)
- Pole profile

- Straight assembly for initial multipole analysis
- 3D model with the original 1.2T central pole (slightly curved pole face)
- DQ with specific end poles

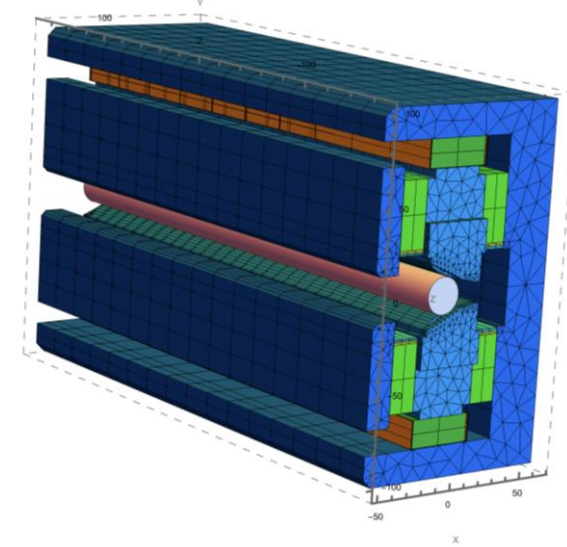
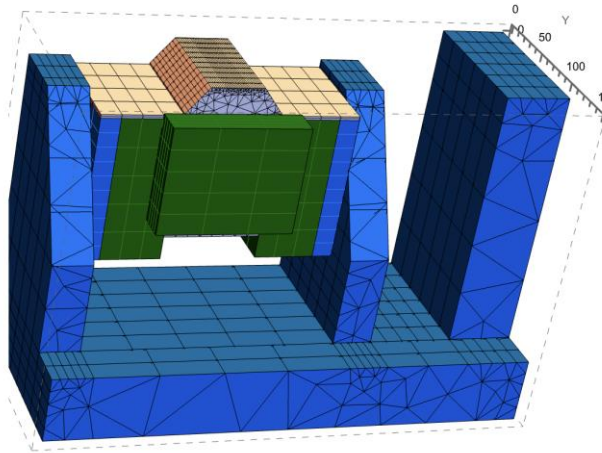
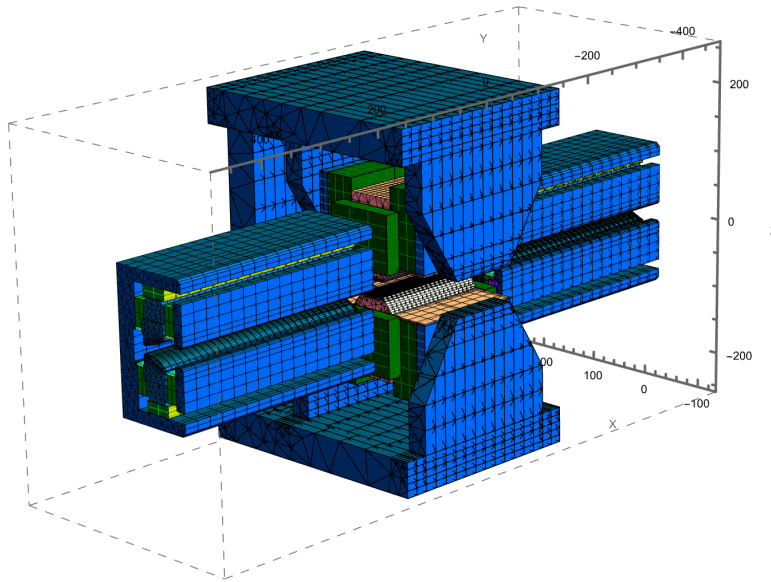

Norm. $b_n$ @ $r=5\text{mm}$	b1	b2	b3	b4	b5	b6	b7	b8	b9	b10
Ori. DNL	1	-0.1184	7.338E-03	1.066E-03	-2.674E-04	-3.491E-05	3.232E-08	1.150E-06	3.652E-07	-6.597E-08
Prop. DNL	1	-0.1219	-2.51E-05	-6.41E-06	-1.39E-04	-1.70E-05	-4.84E-06	5.42E-06	-2.07E-06	-6.69E-08

- A significant reduction of the sextupole and octupole contents in DNL seems feasible



- Lattice includes 25 different Quadrupoles (162) and ReverseBends (192)
- Fixed gradient Quadrupole and ReverseBend
- 4 different pole cross-sections
- Length adjusted to match lattice requirements
- ReverseBends are quadrupoles with an offset
  - $<0.8$  mm for short ReverseBend (DIC)
  - 0.18 mm to 2.45 mm for long ReverseBend (DIL)
- Attempt to reduce the number of families with shims at the quadrupole ends to adjust the integrated gradient

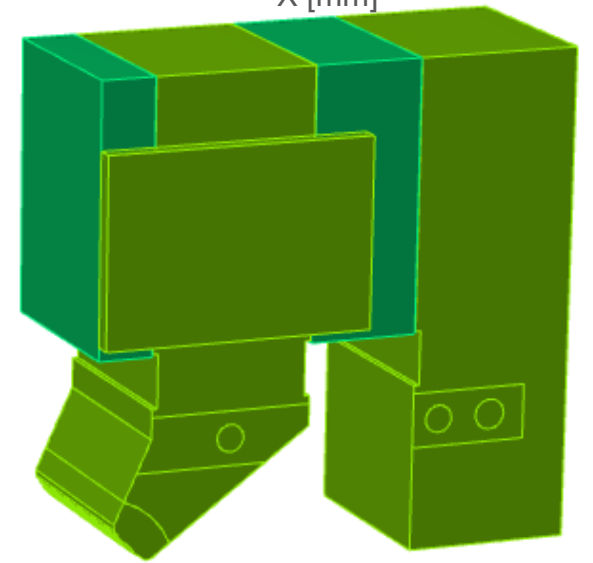
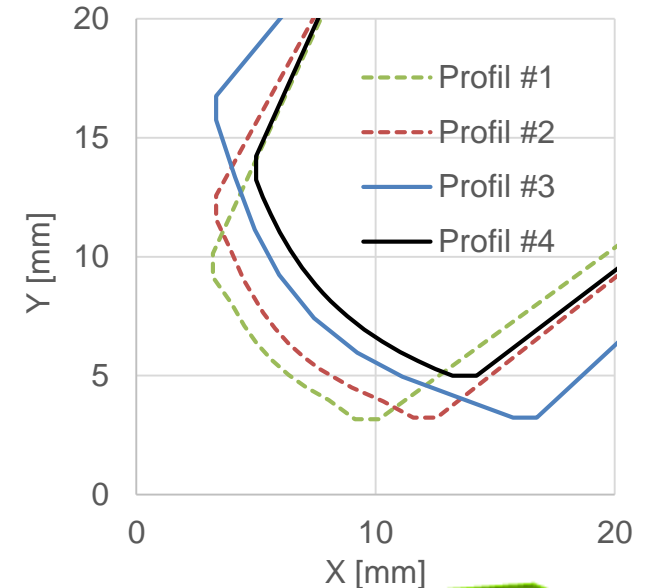

Details presented at Permalics [https://indico.cells.es/event/1229/contributions/2077/attachments/1458/2787/perm\\_soleil.pdf](https://indico.cells.es/event/1229/contributions/2077/attachments/1458/2787/perm_soleil.pdf)



Exemple of quadrupoles with 16 mm aperture: 12 Qp families → 3 families

Spec GL (T)	-7.85	-8.47	-9.26	9.49	-9.5	-9.61	-9.7	9.84	11.5	11.9	12.05	12.67
Quantity	8	8	16	8	16	8	8	8	16	16	8	8
Mech. Length when Gint {Quad} adj. to lattice [mm]	66.94	71.13	76.36	77.91	77.97	78.69	79.29	80.19	91.42	94.16	95.23	99.57
Mech. Length when Gint {Quad+Shim} adj. to lattice	Quad [mm]	66.5	66.5	76.5	76.5	76.5	76.5	76.5	97	97	97	97
	Shim [mm]	3.63	0.12	3.43	2.11	2.06	1.46	0.96	0.2	7.01	4.69	3.8

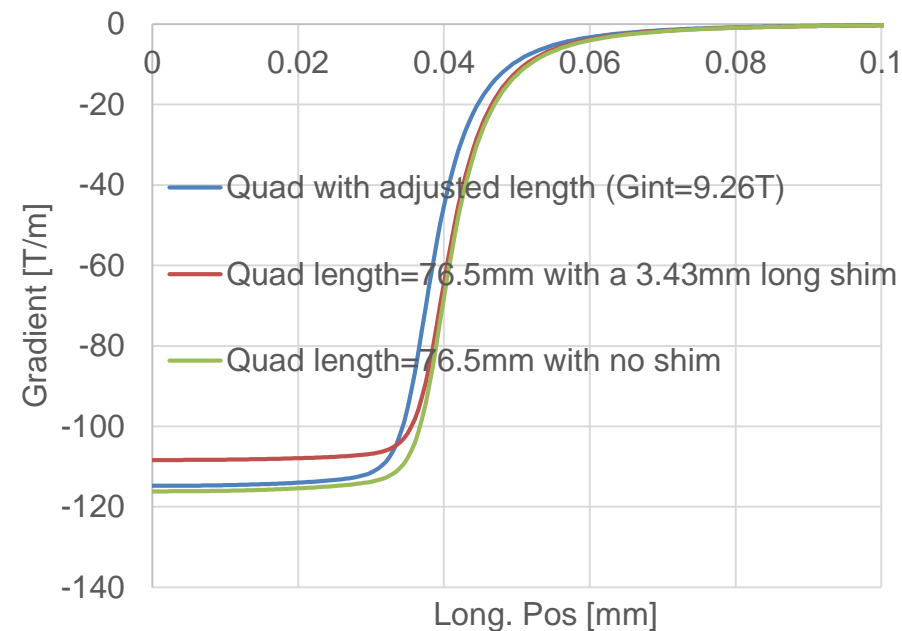
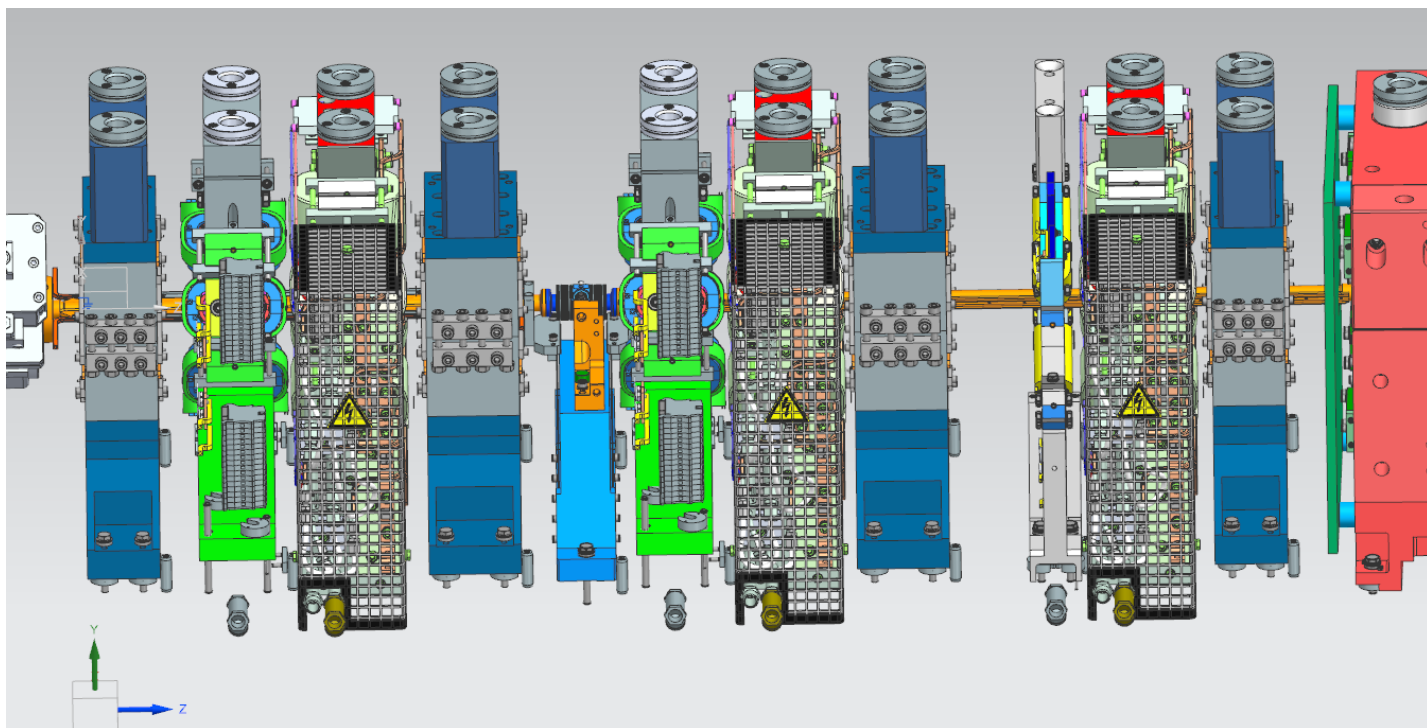

A first quadrupole prototype delivered at SOLEIL in early 2021

- 16mm aperture, 101.5mm long
- Include coils for heating
- Non optimized profile to exhibit specific harmonics (b4 and b6)
- A tight tolerance of 5 $\mu$ m specified on the pole tip
- Magnet block size 50 mm x 20(M) mm x 20.3 mm

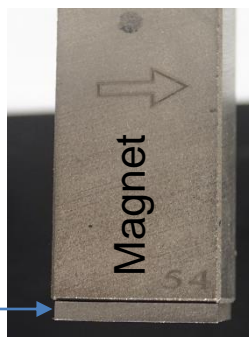
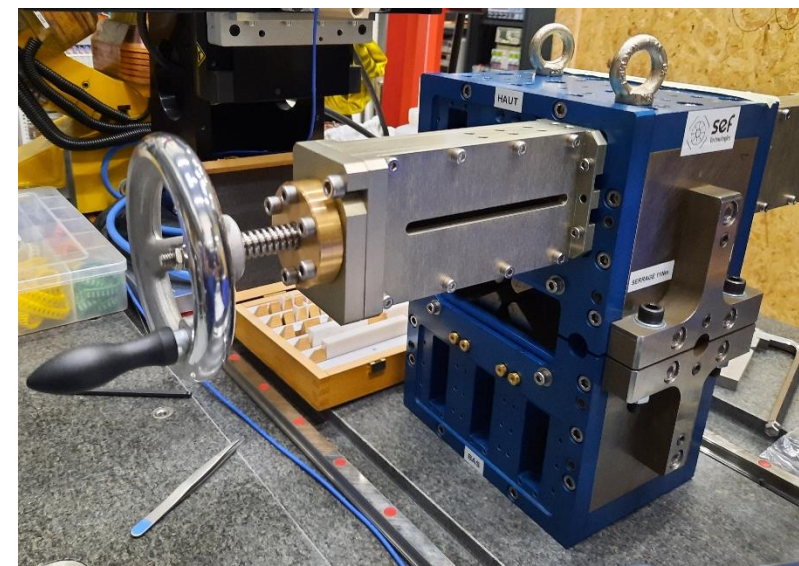
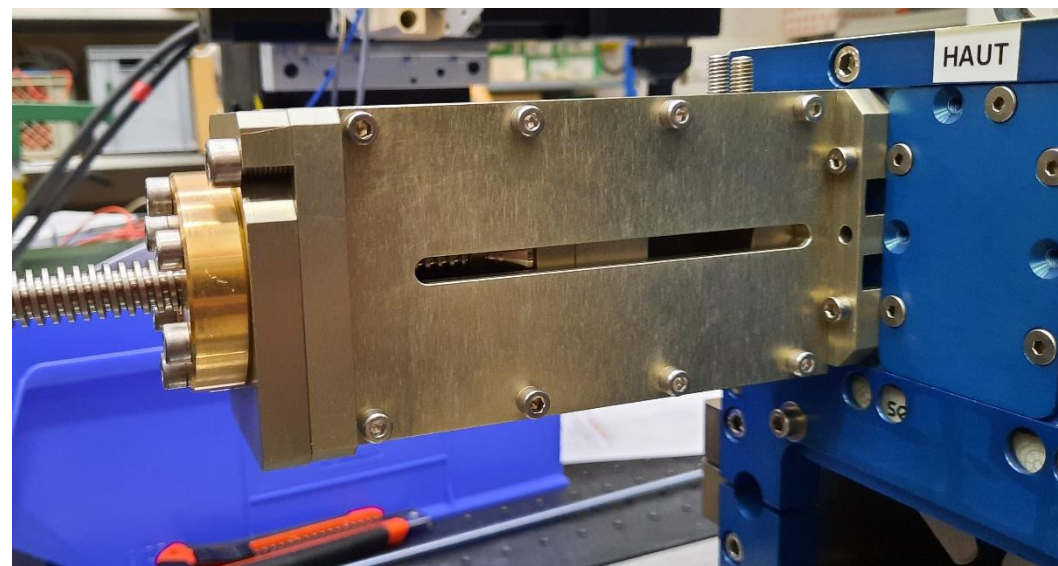

Thermoflux Shim



- 0.5% difference between b2 measured (56.82Tmm) and computed (57.08 Tmm)
- 2 units difference between b6 computed (-60) and measured (-58)

Multipole at r=5mm

Norm. Harm.	b1	b3	b4	b5	b6	b7	b8	b9	b10
Error-free model	0	0	-7.3	0	-60	0	-1	0	-5
Model with pole-tip error	0	-3	-14	-1	-62	0	-0.6	0	-5
Measured	0	3.4	-21	3	-58	1	1.9	-1	1.7

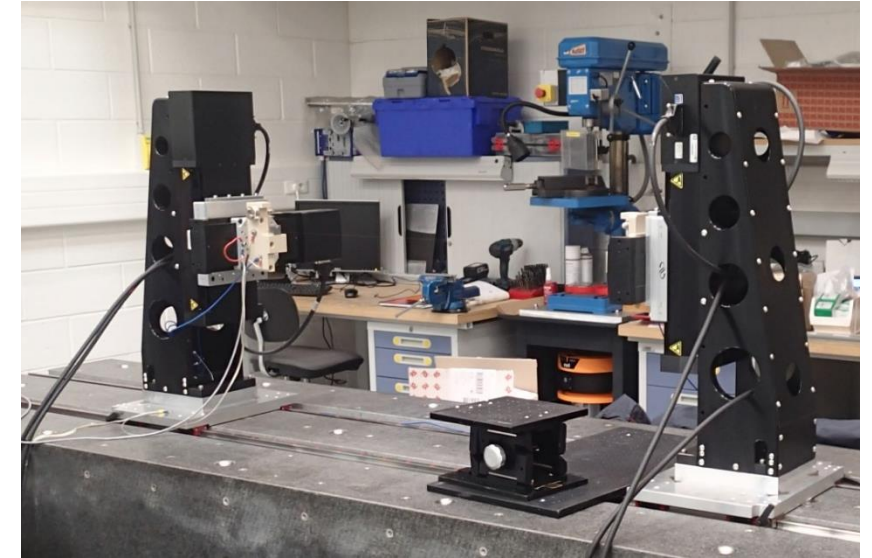
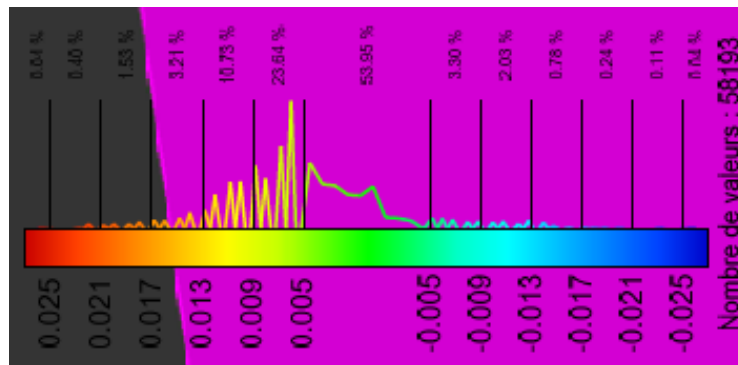
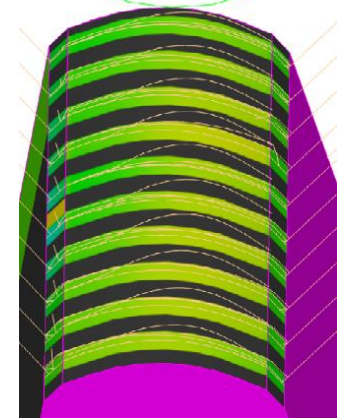

G. Le Bec, J. Chavanne and Ch. Penel, “Stretched wire measurement of multipole accelerator magnets”, *Phys. Rev. Accel. Beams*, vol. 15, Feb. 2012, Art. no. 022401

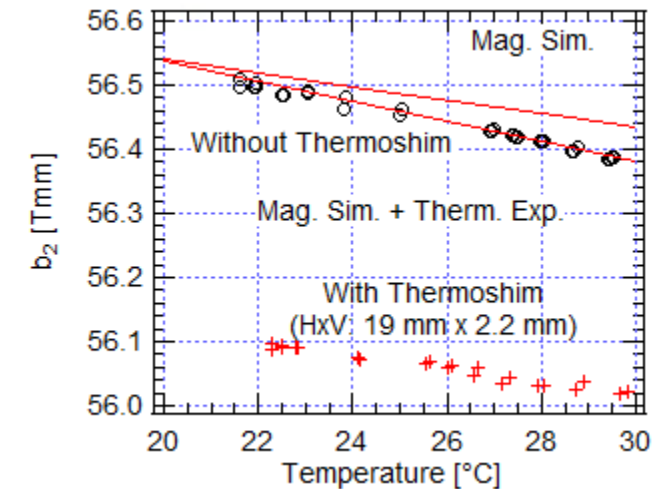
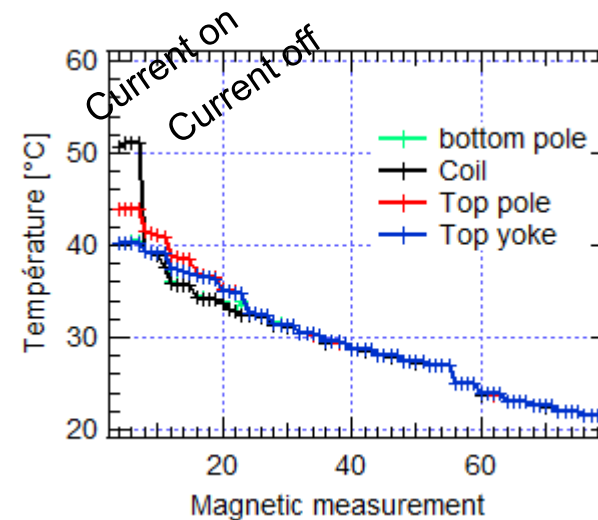



- Magnetic center computed from magnetic measurement
- Thermal expansion measured by dial gauges
- For a 4°C temperature increase of the quadrupole prototype #1, a 16µm mech. elongation (dial gauge) and a 20µm vertical axis shift are measured
- The vertical magnetic axis linearly varies w.r.t the temperature increase at a rate of 5µm/°C

Cu pipe diam.: Øint =14mm/ Øext =15mm

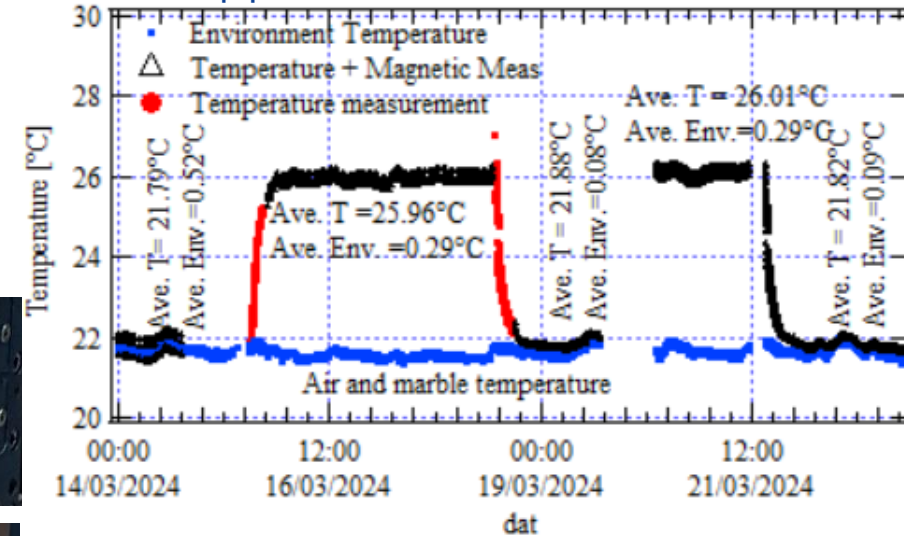

Cu pipe diam.: Øint =12mm/ Øext =14mm

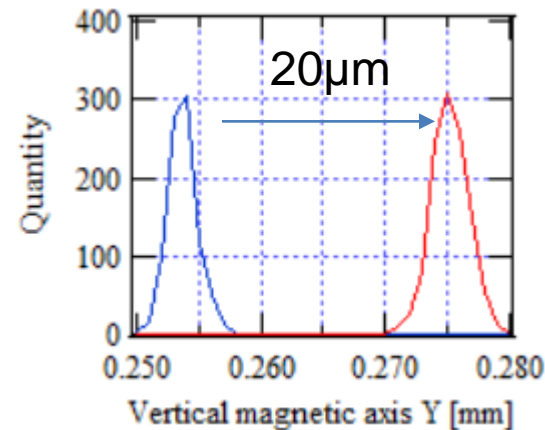
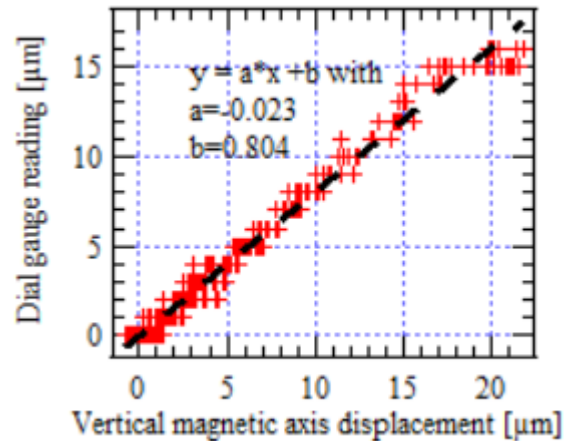
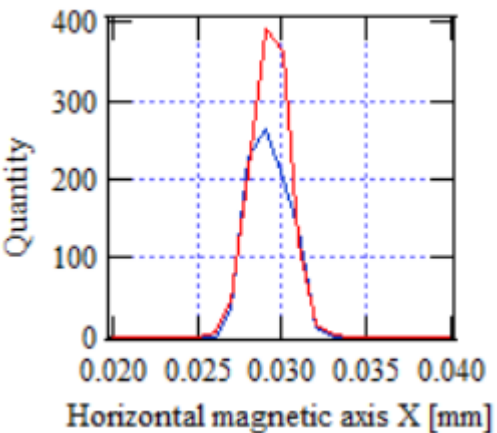
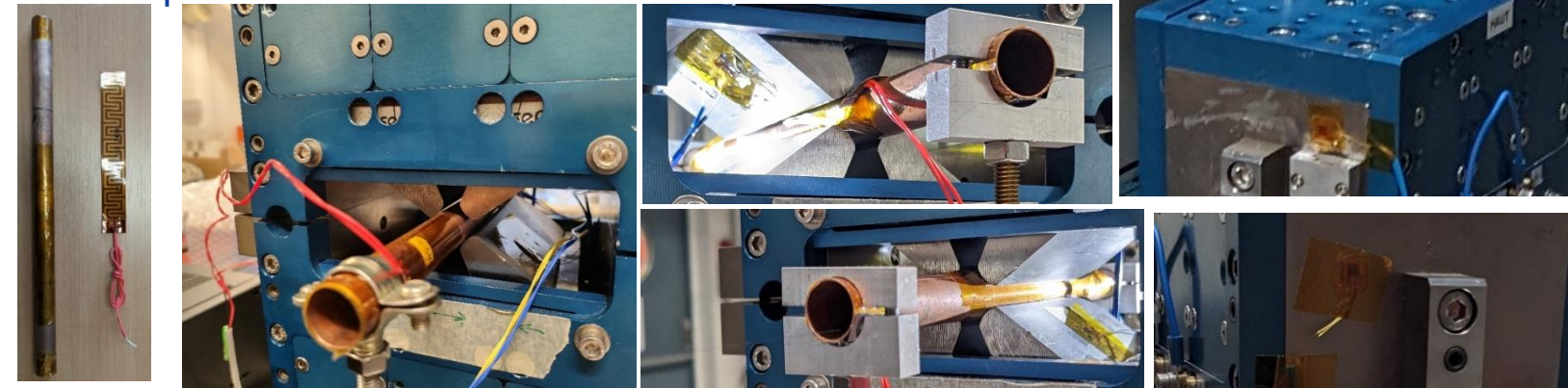
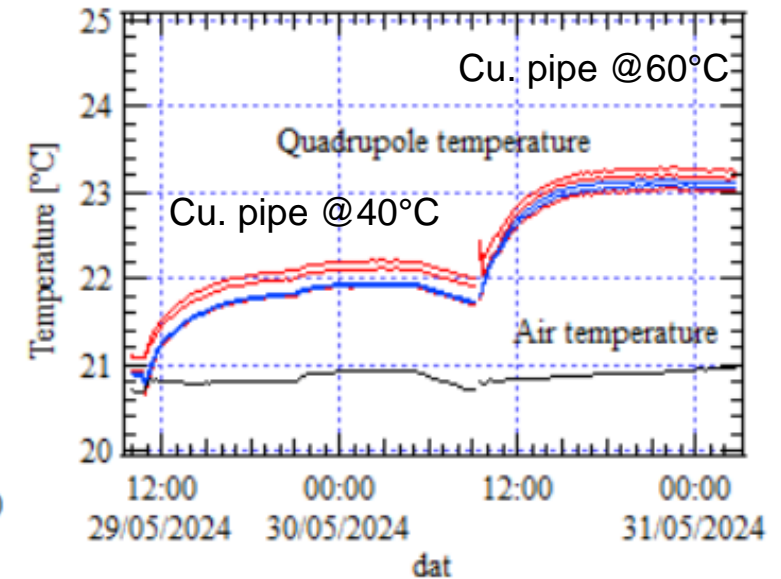

A second prototype delivered in March 2024

- To validate machining process on a 182.7mm long quadrupole
- Simplified design
- 21mm diameter aperture
- Manufacturer specialized in EDM selected, no prior experience in magnet
- Most of the parts were EDM machined

Multipole at  $r=8\text{mm}$

harm. N	1	2	3	4	5	6	7	8	9	10
TOSCA	0.00	10000	0.00	-0.12	0.00	-0.13	0.00	1.48	0.00	0.04
Mesure	1.16	10000	0.75	2.29	-0.66	-5.69	-0.56	3.42	-1.21	-3.61

- 0.147% difference between expected and measured  $b_2$
- Few units on  $b_4$  and  $b_6$  hamonics

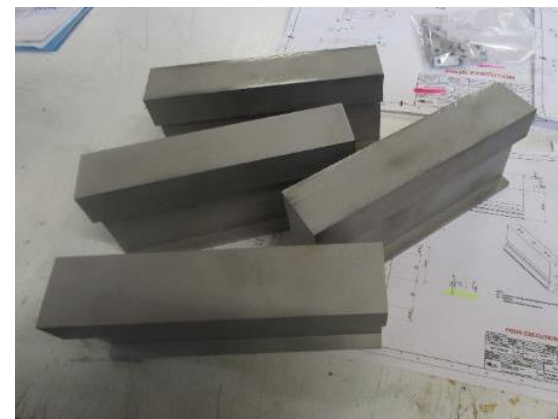
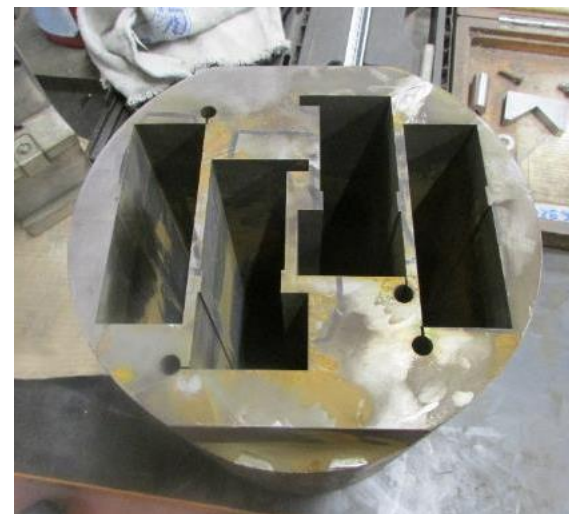
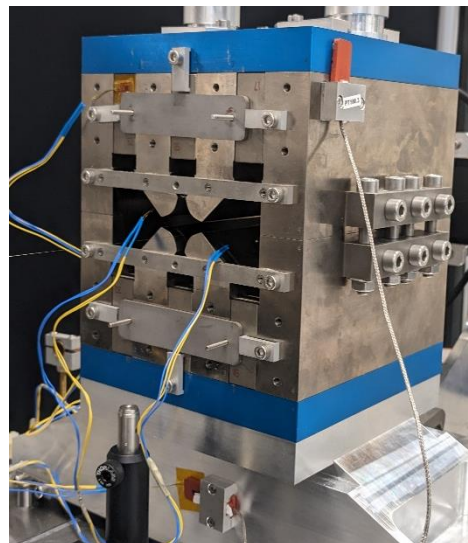
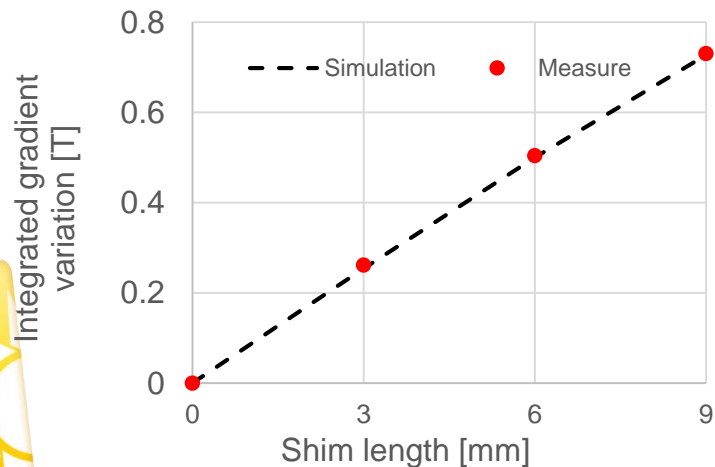



- 9 types of sextupoles ( total number 412)
- Bore diameter : 16 mm and 21 mm with a good field region : +/- 5 mm
- 3 Normal profiles with interpole distance 6.2 and 7 mm
  - 60 mm : sextupolar strength ( $\frac{1}{2} B''$ ) : 500 T.m<sup>-2</sup> to 8000 T.m<sup>-2</sup>
  - 80 mm : sextupolar strength ( $\frac{1}{2} B''$ ) : 5300 T.m<sup>-2</sup> to 7300 T.m<sup>-2</sup>
  - 110 mm : sextupolar strength ( $\frac{1}{2} B''$ ) : 6000 T.m<sup>-2</sup> to 8100 T.m<sup>-2</sup>
- 1 profile with beamline notch with interpole distance 7.5 mm
- 1 profile with for canted section with 21mm diameter aperture and interpole distance of 10 mm
- 1 mrad Hor. And Ver. Dip. Cor

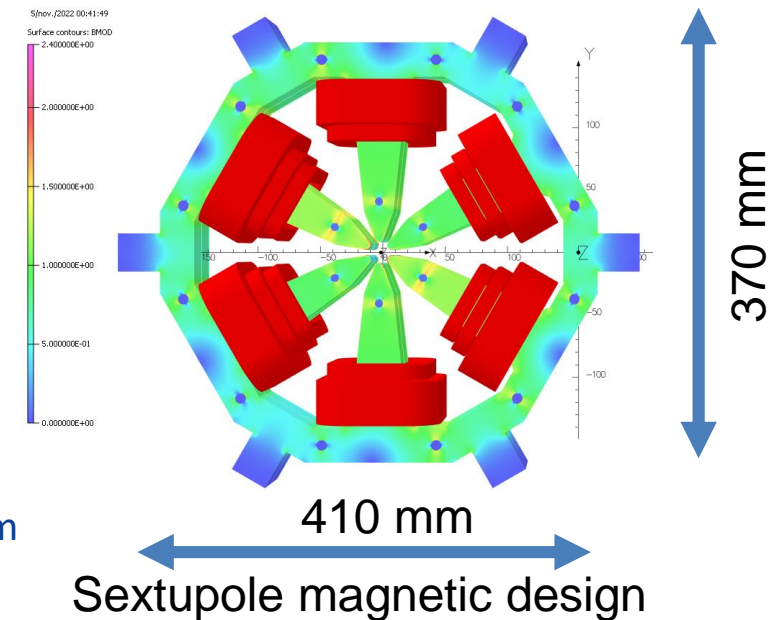

Dipole/Sextupolar Component

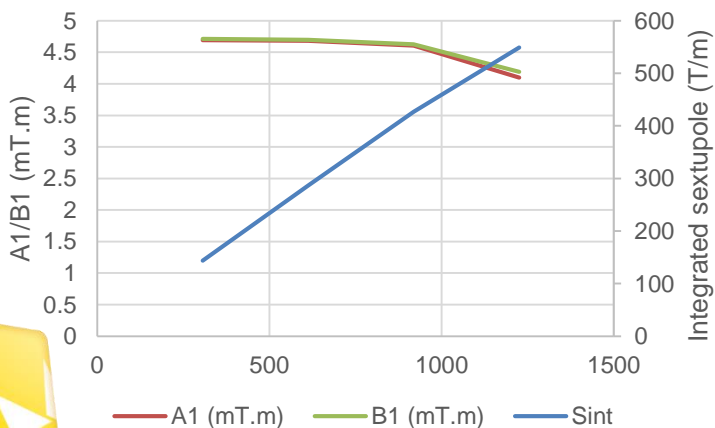

Interpole [mm]	Diam. [mm]	Length [mm]	Sint [T/m]	A.t	A	CH drop	CV Drop	$\Delta$ Sint / CH 100%	$\Delta$ Sint / CV 100%	B9	B15	B21	Max. Hor. Cor. [mrad]	Max. Ver. Cor. [mrad]
										unit				
6.2	16	60	550	1300	40.6	5.9%	4.8%	1.5%	1.1%	143.6	1.4	0.1	0.99	0.90
6.2	16	80	680	1230	38.4	2.2%	1.6%	0.6%	0.4%	144.7	1.3	0.1	1.22	1.12
6.2	16	110	1000	1284	40.1	2.1%	1.5%	0.6%	0.4%	145.4	1.3	0.1	1.57	1.44
6.2	21	60	350	1900	59.4	39.1%	35.7%	2.2%	1.8%	7.2	0.1	0.1	0.81	0.74
7.0	16	60	550	1440	45.0	9.5%	8.0%	2.1%	1.5%	207.8	7	0.3	0.97	0.88
7.0	16	80	680	1350	42.2	3.5%	2.7%	0.9%	0.6%	209.5	7	0.3	1.19	1.09
7.0	21	60	350	1900	59.4	34.6%	31.5%	2.4%	1.8%	14.1	0	0	0.81	0.73
7.5	16	80	680	1600	50.0	29.7%	39.2%	9.1%	2.1%	235.9	9.6	0.5	1.17	1.04
10.0	21	60	350	2600	81.3	54.2%	50.4%	1.1%	0.9%	44.7	0.5	0	0.74	0.67



A sextupole prototype with notch was delivered to SOLEIL in October 2023

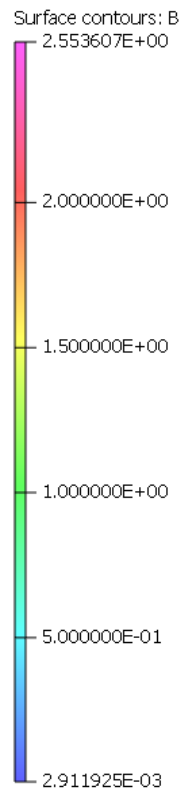
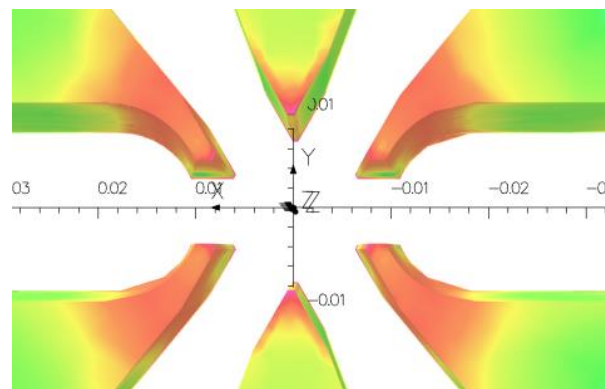
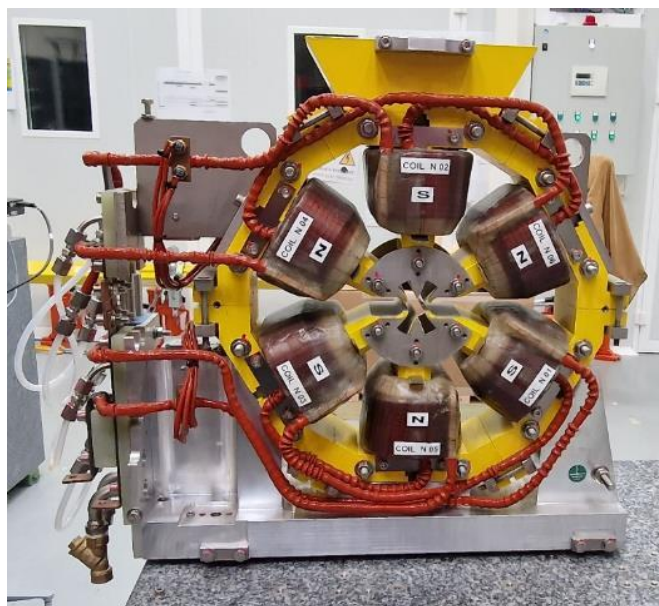

Magnetic parameters	
Max. Ampere.turns	9000 A.t
Max. Sextupolar strenght	8200 T.m <sup>-2</sup>
Mechanical parameters	
Magnet Width	410 mm
Magnet Height	365 mm
Yoke Length	80 mm
Steel weight	33 kg
Electrical and hydraulical parameters main Coil	
Max. current	47 A
Magnet voltage	3 V
Magnet electrical power	150 W
Water speed	1.72 m/s
Temperature increase	1.5 °C
Pressure drop	6 bar
Hollow conductor for the main coil	
Conductor size	5 x 5 mm <sup>2</sup>
Hole Diameter	3 mm
Number of turns	32
Average turn length	0.340m

Horizontal corrector	
Number of turns	20/40
Max. current	10 A
Corrector voltage	5 V
Corrector electrical power	100 W
Vertical corrector	
Number of turns	32 tours
Max. current	20 A
Corrector voltage	4.2 V
Corrector electrical power	85 W
Conductor size	5x0,8 mm <sup>2</sup>

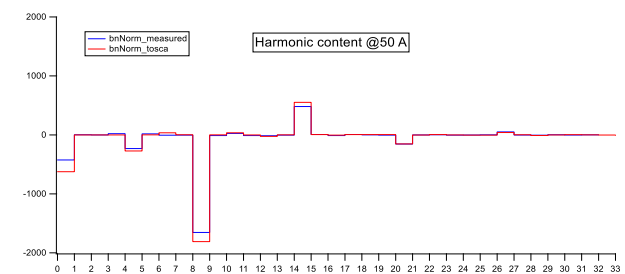
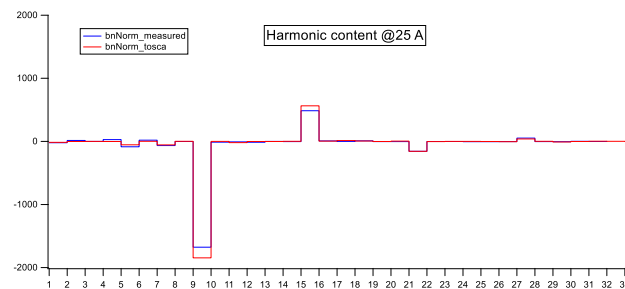
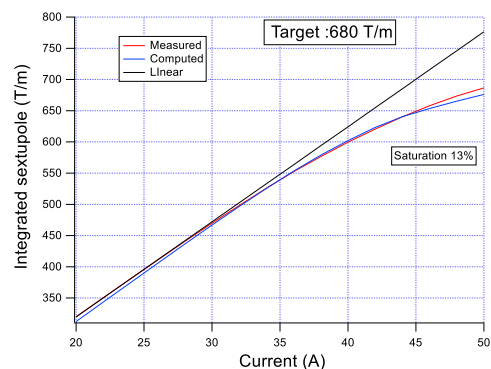

		1	2	3	4	5	6	7	8	9	10	11	12	13	14	15	16	17	18	19	20	21
50 A	Measured	-425	2	10000	20	-232	17	-5	-3	-1655	-11	25	-12	-15	-3	482	6	-11	7	0	-4	-155
	Computed	-624	-1	10000	-1	-273	1	35	2	-1809	0	36	-1	-25	1	552	5	-4	5	5	5	-153
25 A	Measured	-21	15	10000	28	-86	19	-66	-2	-1677	-13	-8	-13	0	-3	487	8	0	9	-3	-2	-156
	Computed	-14	-1	10000	-1	-53	1	-55	2	-1846	0	-20	-1	-1	2	564	5	13	6	-1	5	-157

Harmonic content @ Rref = 7mm

( $b_n$  expressed in units of  $10^{-4}$ )

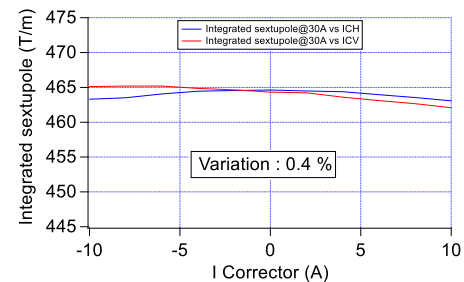
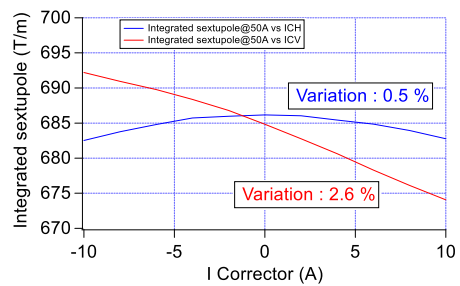
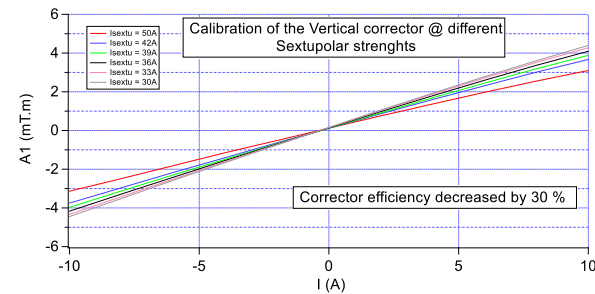
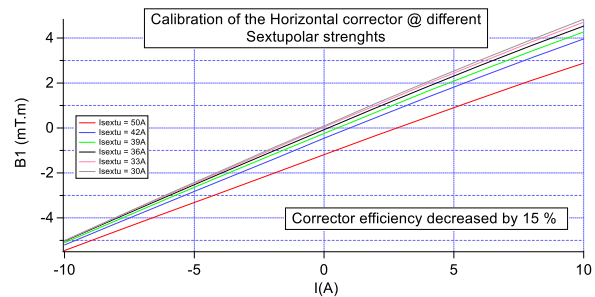



- 1 octupole and 1 quadrupole corrector to be prototyped
- Orders to be placed before 2025

3 coils per pole:

- Octupolar coils 120 At: 16 spires  $5 \times 0.8 \text{ mm}^2 \rightarrow 10 \text{ A}$
- Normal Quad coils 320 At (0.6T): 12 spires  $5 \times 5 \phi 3 \text{ mm}^2 \rightarrow 30 \text{ A}$
- Skew Quad coils 320 At: 16 spires  $5 \times 0.8 \text{ mm}^2 \rightarrow 20 \text{ A}$

	Design 1	Design 2
Int. Grad. [T]	1	
Aperture diam. [mm]	19	21
Yoke Length [mm]	24	29
Gap [mm]	7	10
Ampere-Turn @1T	1050	1100

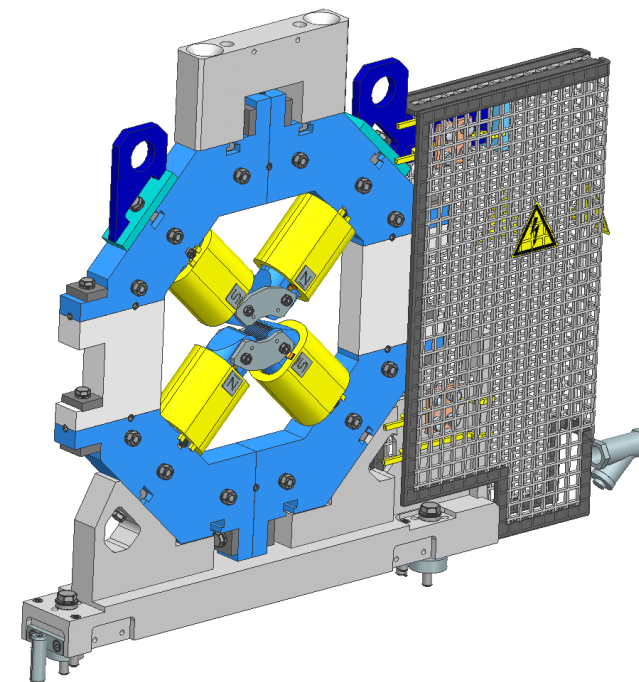
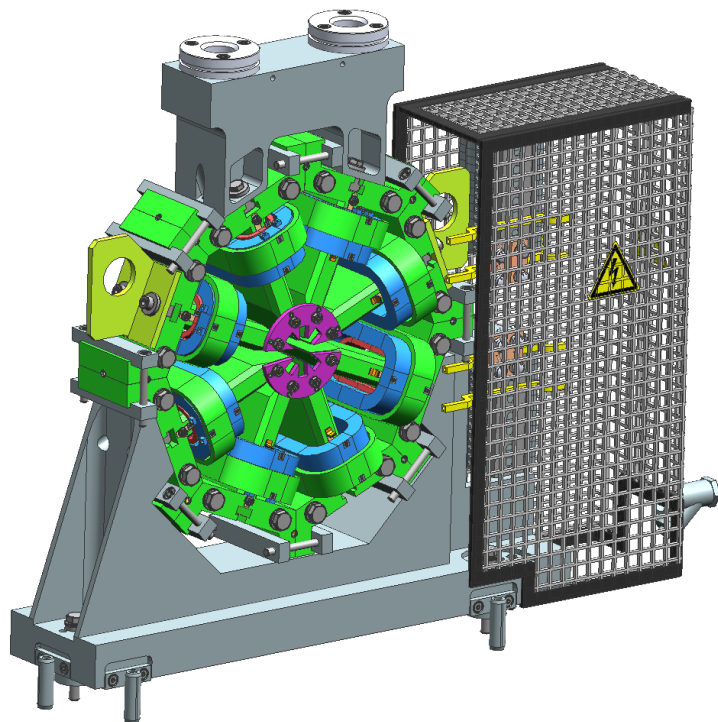

- Tolerance on magnet-to-magnet center alignment tighten from  $\pm 25\mu\text{m}$  to  $\pm 10\mu\text{m}$  in matching straight sections.
- Such alignment tolerances already achieved with vibrating wire
- Dedicated poster by Saif Mohd KHAN on Wednesday

**23rd International Magnet Measurement Workshop: IMMW #23**  
6-11 Oct 2024  
Parkhotel Bad Zurzach, Switzerland

**Initial Measurement Plan for SOLEIL-II by Vibrating Wire and Pulsed Wire Measurement Techniques**

S. M. Khan #, M. E. Couprie, C. Kitegi, F. Marteau, T. Mutin, K. Tavakoli, S. Ducourtieux and M. Valléau

Magnetism and Insertions Group (GMI), Accelerator and Engineering Division  
Synchrotron SOLEIL, Saint Aubin-91190, France  
#saif-mohd.khan@synchrotron-soleil.fr

## ABSTRACT

The construction of next-generation light sources faces a critical challenge of high-precision alignment of the ring magnets. With the aim to acquire optimal and stabilized synchrotron radiation for upgrade of SOLEIL, the magnetic elements of the synchrotron must be aligned with very high accuracy. The magnetic measurement techniques such as vibrating wire and pulsed wire can be implemented to determine and align the magnetic center of various magnets on a girder simultaneously. SOLEIL is equipped with a pulsed and vibrating wire measurement bench. The vibrating wire magnetic measurement method involves the excitation of harmonics of vibration due to Lorentz forces in the current carrying wire under the influence of magnetic field. By analyzing these oscillation harmonics, the magnetic field can be reconstructed with accuracy. The pulsed wire magnetic measurement is a vital tool for accurately mapping the magnetic fields, offering precision and sensitivity for the measurements. The pulsed wire method operates by sending an electric pulse through a taut wire placed within the magnetic field to be measured. As the pulse travels along the wire, it interacts with the magnetic field, generating a Lorentz force. This force causes a small deflection in the wire, which can be measured using optical detectors. The deflection of the wire is directly proportional to the magnetic field strength at each point along the length of the wire. By recording the wire's motion as a function of the time, the spatial distribution of the magnetic field can be accurately reconstructed.

## MOTIVATION

**The requirement of magnet-to-magnet center alignment in the straight matching sections within tolerance of  $\pm 10\mu\text{m}$  for SOLEIL - II**



Prototype of the magnetic elements of the new storage ring lattice

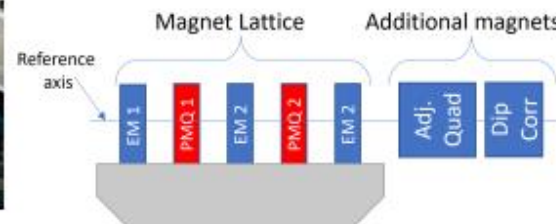

>> Correlated Alignment on a Girder <<

Vibrating Wire (VWM) method<sup>1</sup> should allow us to achieve required performance.

Successfully implemented on different projects<sup>2-4</sup> but implemented so far to align EM magnets, what about PM quadrupole (PMQ)?

Pulsed Wire (PWM)<sup>5,6</sup> could be a candidate as well → All the magnets can be installed on the girder and aligned one by one

- SOLEIL II lattice is complex, includes a lot of different magnet types
- Push further the magnetic design of DNLs as DQ magnets
- A new lattice that includes these dipoles will be released in early 2024
- Lattice not yet finalized
- Delivery of the dipole prototypes in December
- Order the prototype of the octupole and the quadrupolar corrector
- Measurement of the Crosstalk using sextupole and quadrupole prototypes