



Overview of the ITER magnetics Diagnostic

G. Golluccio

On behalf of the ITER Diagnostics Program
and with the support of the electromagnetic measurement group

The views and opinions expressed herein do not necessarily reflect those of the ITER Organization.

© 2024, ITER Organization



CONTENT

1. Introduction to the ITER project
2. Diagnostics: the “eyes” and “ears” of ITER
3. Magnetics diagnostic for plasma measurements
4. The Magnetics diagnostic zoo
5. Electronics and software
6. Conclusions



ITER's missions

To demonstrate the scientific and technological feasibility of fusion power at industrial scale

HOW DOES IT WORK?

Inject DT gas.

Inject electric current to convert the gas to plasma.

Inject electromagnetic waves.

A strong magnetic cage contains the plasma.

The magnetic structure is generated through a set of coils

THE CHALLENGE: TO CONTAIN AND SHAPE THE PLASMA.

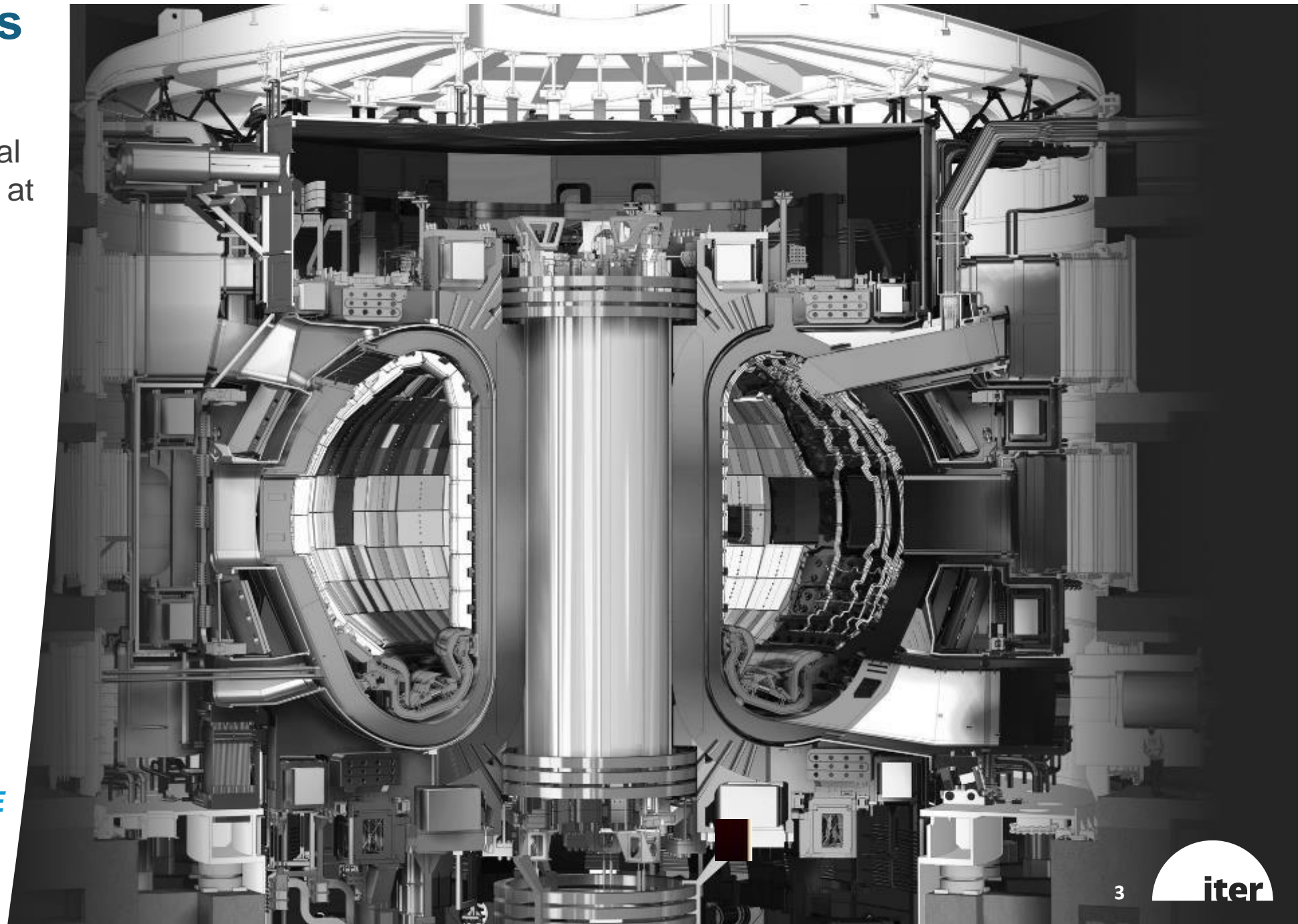

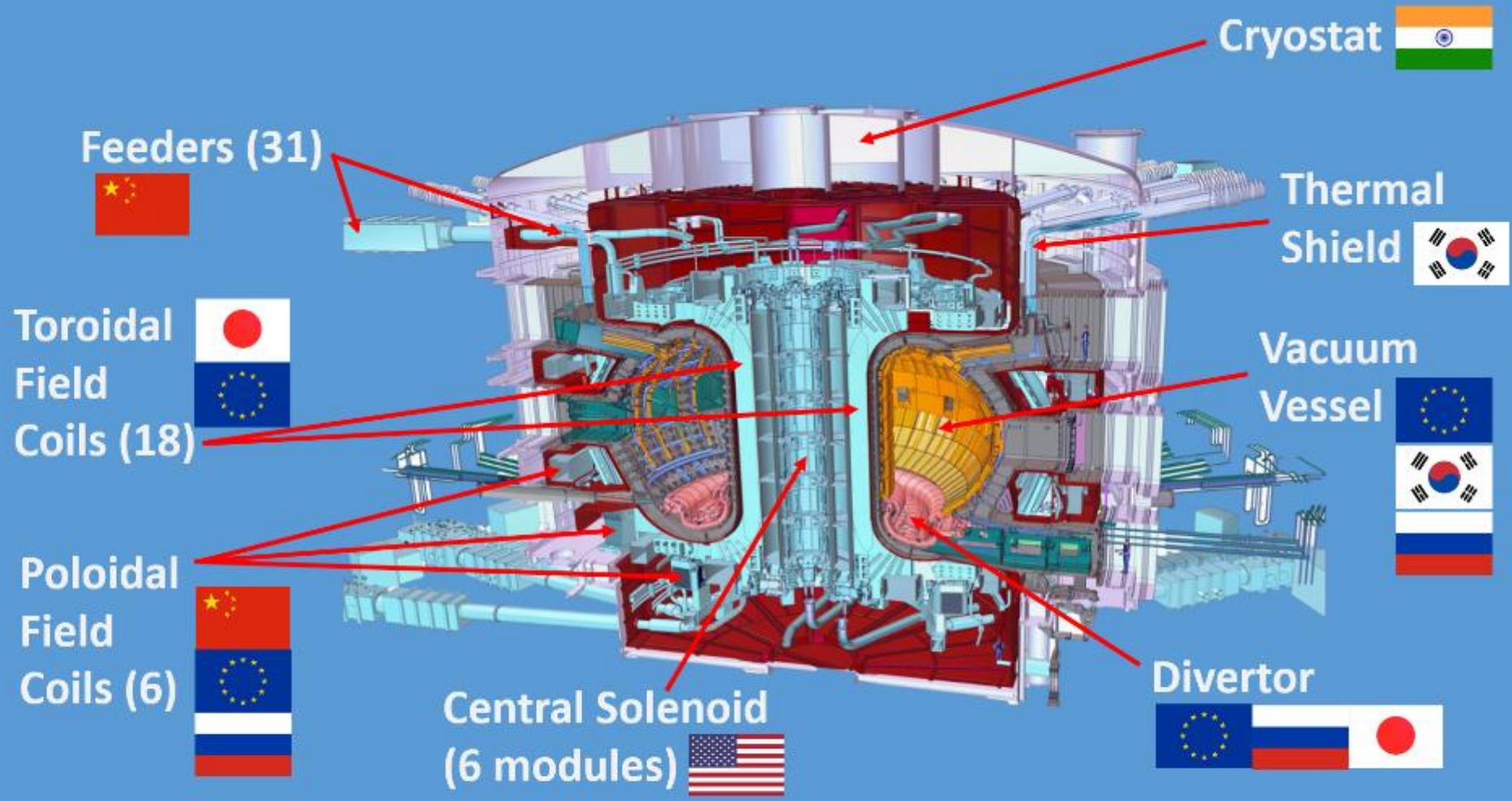

WHO MANUFACTURES WHAT?

The ITER Tokamak is comprised of more than 1 million components. This shows a simplified breakdown of ITER Member contributions.

ITER Members share all intellectual property.

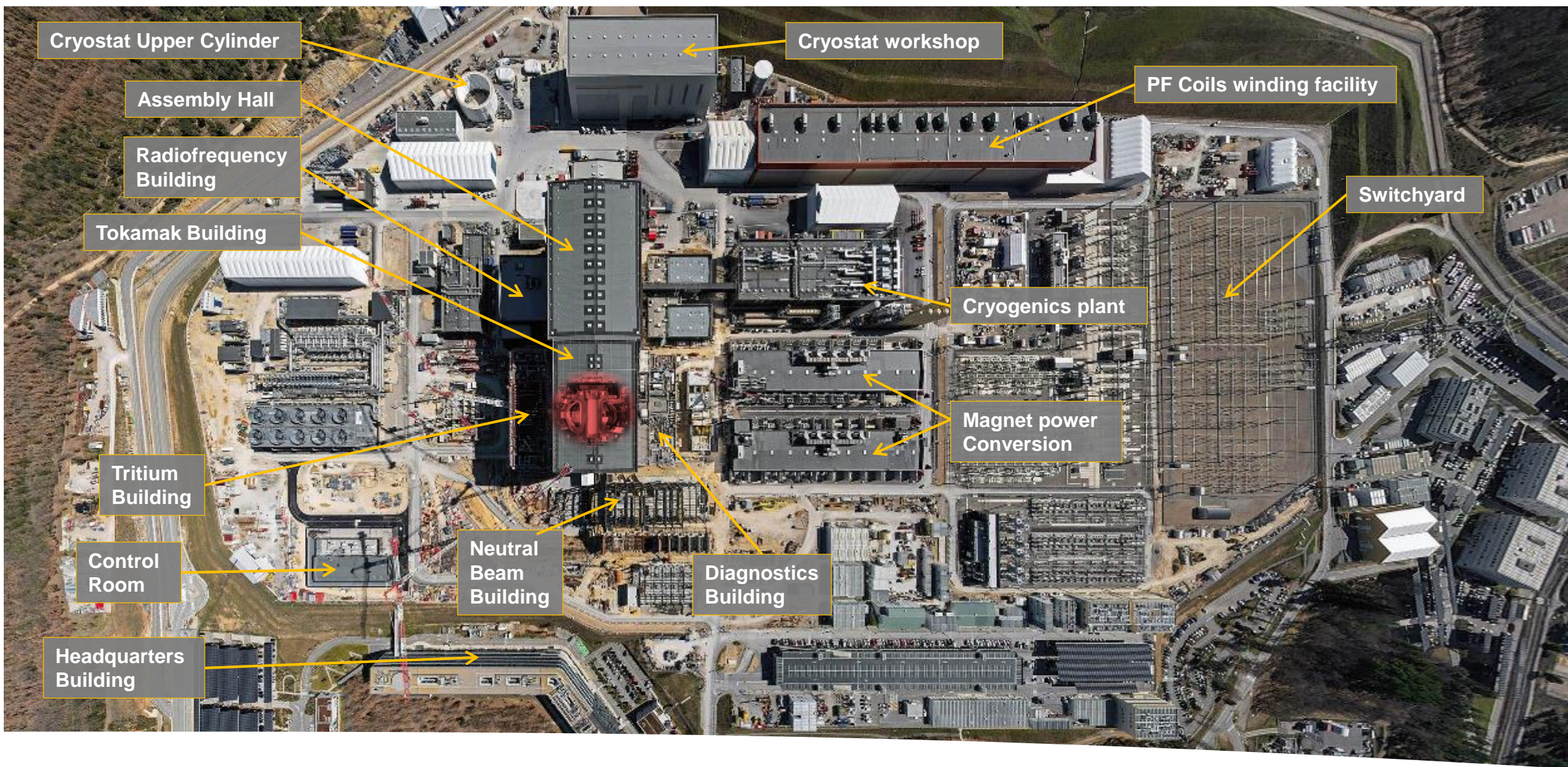

WORKSITE CONSTRUCTION

Aerial perspective, March 2023

ASSEMBLING THE MACHINE

First complete Vacuum Vessel Sector Module lifted in May 2022

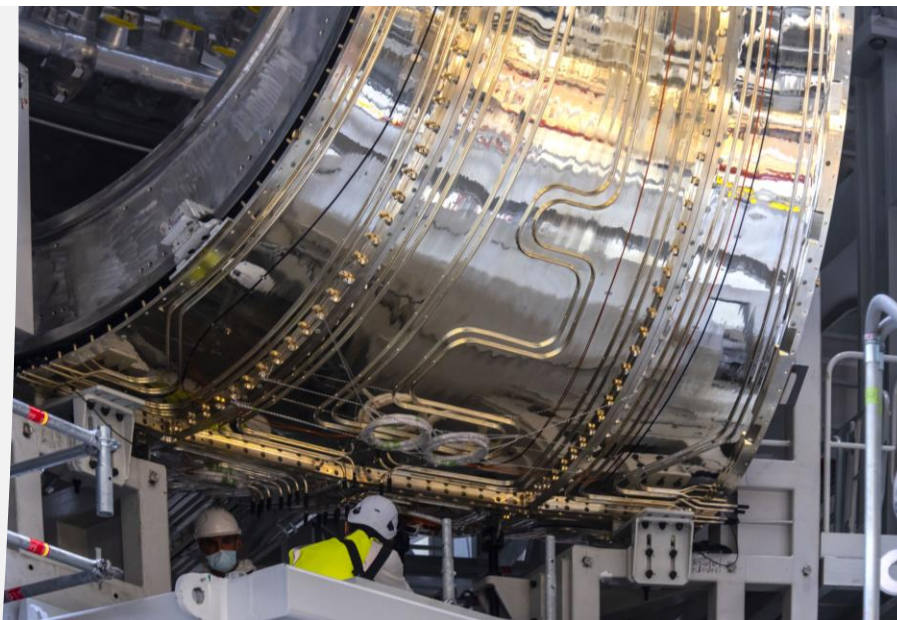

CHALLENGES OF FIRST-OF-A-KIND COMPONENTS

Geometric non-conformities found in Vacuum Vessel sector field joints

Leakage identified in thermal shield cooling piping due to chloride stress corrosion

STATUS

Sector 5 : successfully repaired

Sector 7 (at ITER): successfully repaired

Sectors 6 & 8 (at ITER): repairs in progress

Sector 1 (at ITER): repair to start soon

Sectors 2, 3, 4, 9: manufacturing in progress

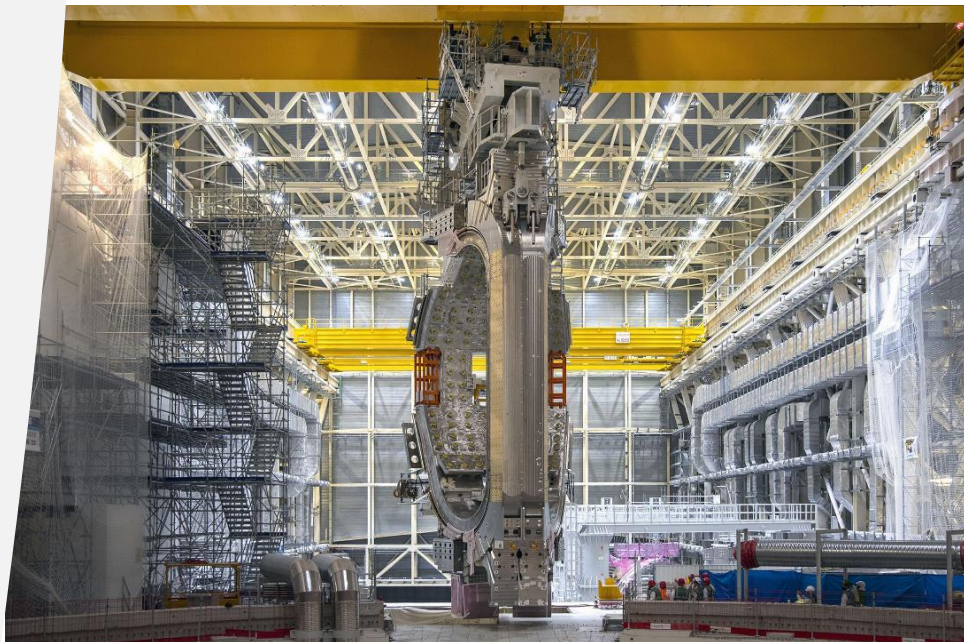

PF/TF/CC MAGNET MANUFACTURING AND DELIVERY

All Poloidal Field coils have been completed and delivered (PF2 pictured at right)

All 19 Toroidal Field coils (18 + 1 spare) have been completed and delivered.

12 of 18 correction coils have been completed and delivered.

TF testing facility in final design

Last TF coil en route, December 2023



MEASUREMENT

PARAMETERS

More than 100 parameters measured by diagnostics

They are classified in 3 main categories

1. Machine protection parameters

Plasma current, magnetic field map, Radiation power, max surface temperature, neutron flux, Total fusion power, runaway electrons, etc...

2. Basic and Advanced control parameters

Electron and ion temperatures, plasma velocity, electron density, impurity concentrations, Tritium/Deuterium concentration ratio, etc...

3. Physics study parameters

Alpha particle density, fusion power density, energy spectrum, etc...

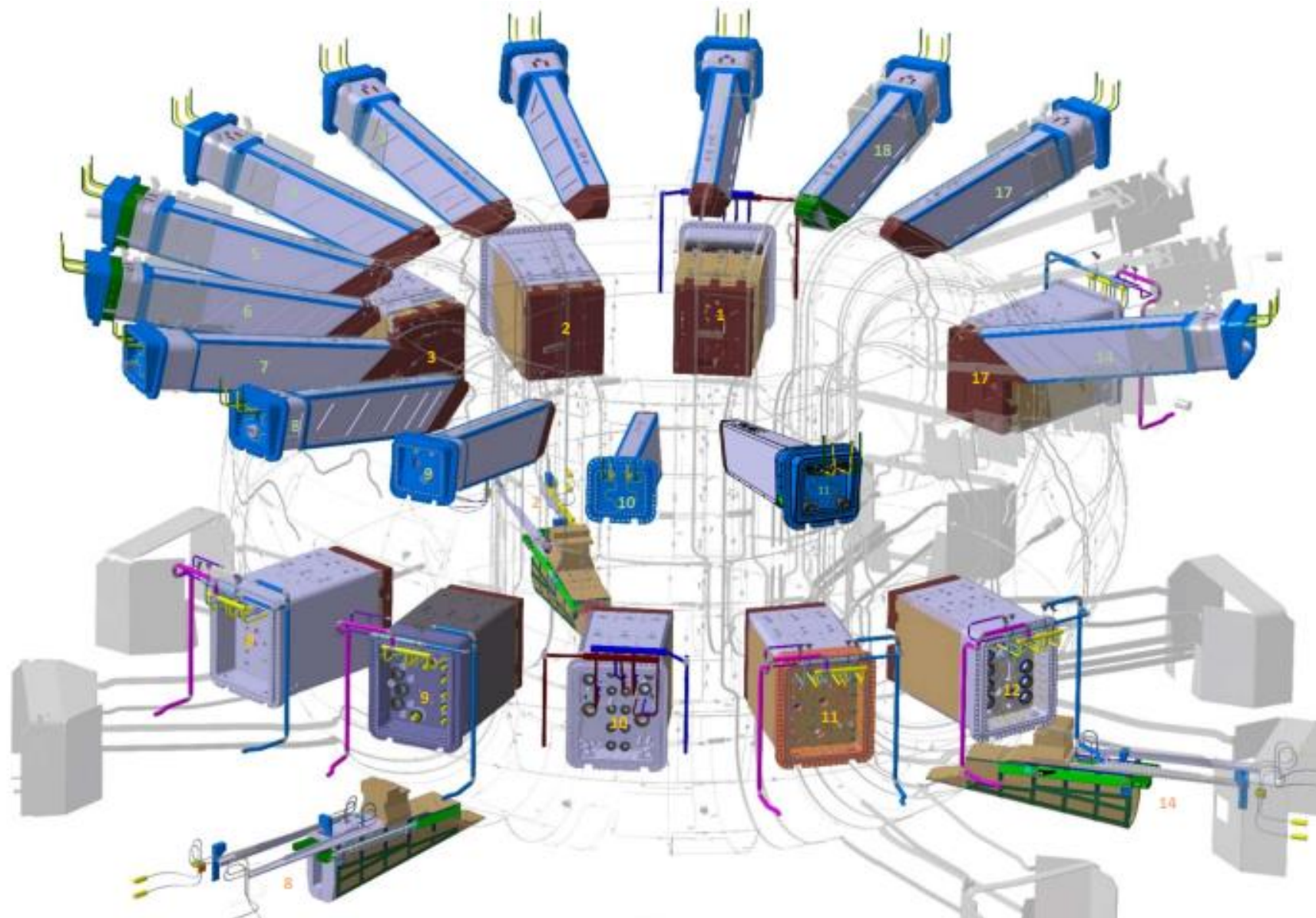

Magnetic diagnostic for plasma measurements

Magnetic diagnostics provide essential measurements for:

1. Machine protection (interlock) and safety
 - Measure the plasma current to avoid reach vessel design limit
2. Basic and Advanced control parameters (real-time measurements)
 - Plasma position and shape, vertical speed, loop voltage
 - Induced currents in the structures (vessel, blanket, divertor)
3. Physics study parameters
 - Plasma instabilities

Which sensors?

External Rogowski and Fiber optic current sensors around the Vacuum vessel

Tangential, radial and toroidal coils and hall probes, flux loops on the external skin of the vacuum vessel

Tangential, radial and toroidal coils inside the vacuum vessel and on divertors

Continuous and partial flux loops inside the vessel

Rogowski coils behind the blanket modules and on the divertor structure

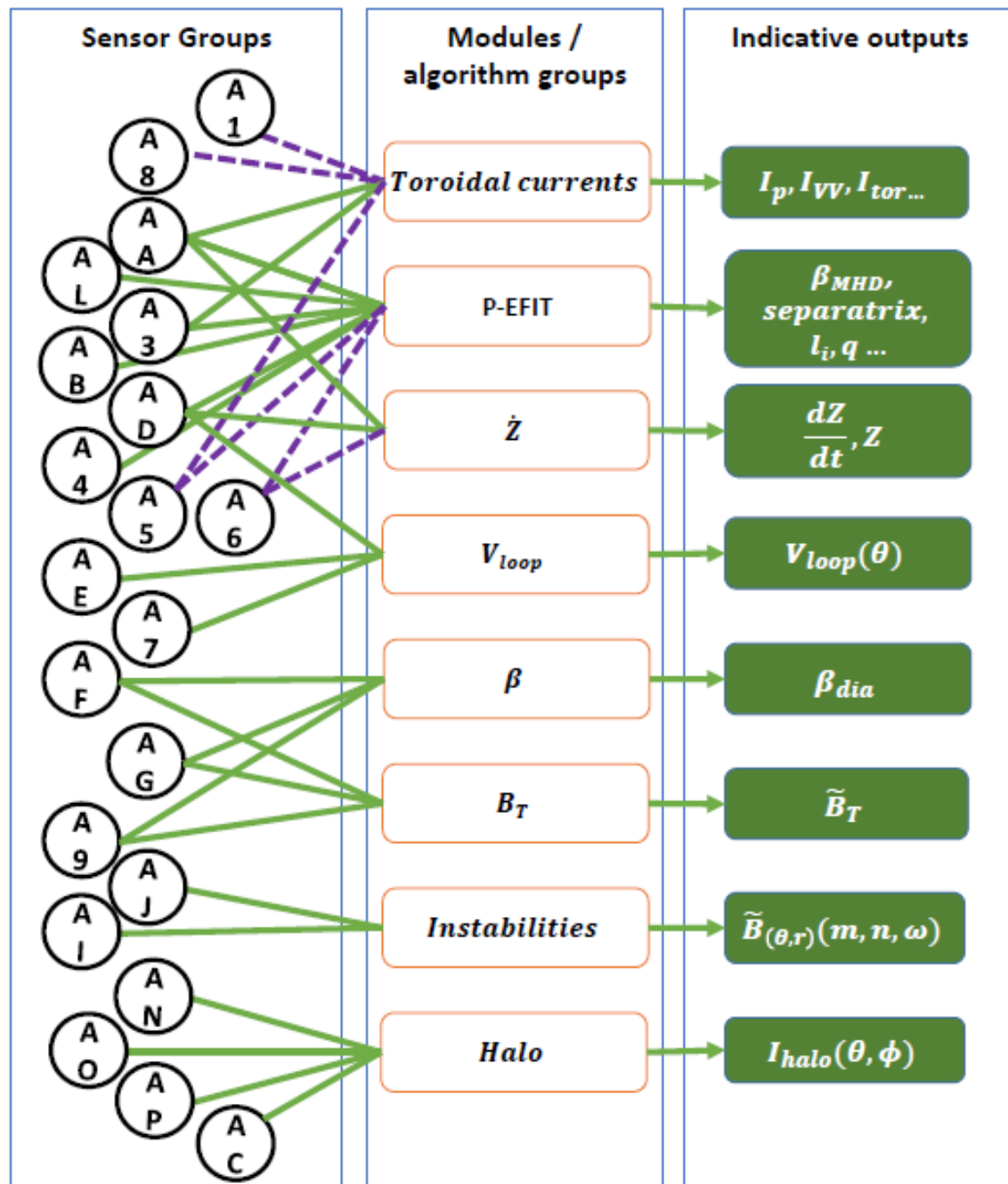

Which sensors?

External Rogowski (A1) and Fiber optic current sensors (A8) around the Vacuum vessel

Tangential (A3), radial (A4) and toroidal coils (A9) and hall probes (A5), flux loops (A7) on the external skin of the vacuum vessel

Tangential (AA,AJ), radial (AB) and toroidal coils (AC,AG) inside the vacuum vessel and on divertors (AL,AO)

Continuous and partial flux loops inside the vessel (AE,AF,AG,AI)

Rogowski coils behind the blanket modules and on the divertor structure (AN,AP)

Magnetic diagnostic for plasma measurements:

measuring the plasma position and shape

- For an ITER pulse to run, the plasma has to grow from a modest cylinder to a size that almost fills the machine
- Form the X-point for proper power exhaust
- At the end of the pulse, reverse the process

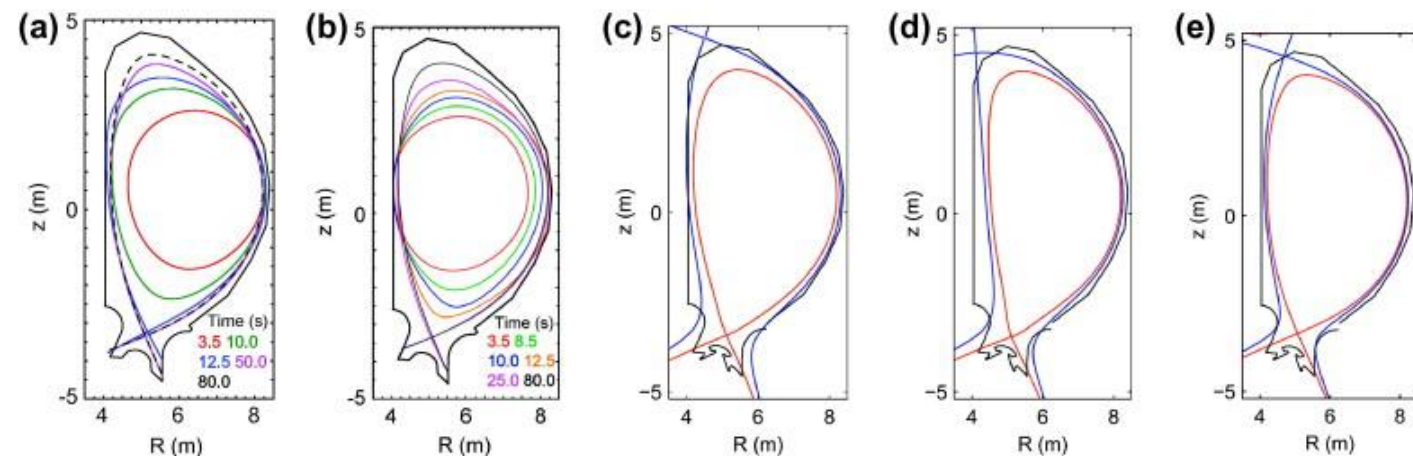

R.A. Pitts et al, Journal of Nuclear Materials Volume 415, Issue 1, Supplement 2011 S957 - S964

There are surfaces of constant magnetic flux (flux surfaces)

For an axisymmetric plasma, the set of (R,Z) coordinates of this flux surface is “the shape”

The shape is a function of flux surface – but the one that matters most is the one that touches the first wall.

To measure the shape, we need to make a topographic map of magnetic flux and find the outermost contour of this map that touches the first wall
How do we make this flux map?

- Measure flux pattern at the edge and extrapolate to the plasma surface with a combination of coils and partial and saddles loops

- The best performance is obtained using all measurements and physical constraints (Grad-Shafranov equation), to deduce the most probable shape
- Solutions are never unique but are strongly constrained near the edge by the magnetics.
- Other diagnostics can be used to constrain internal current profiles

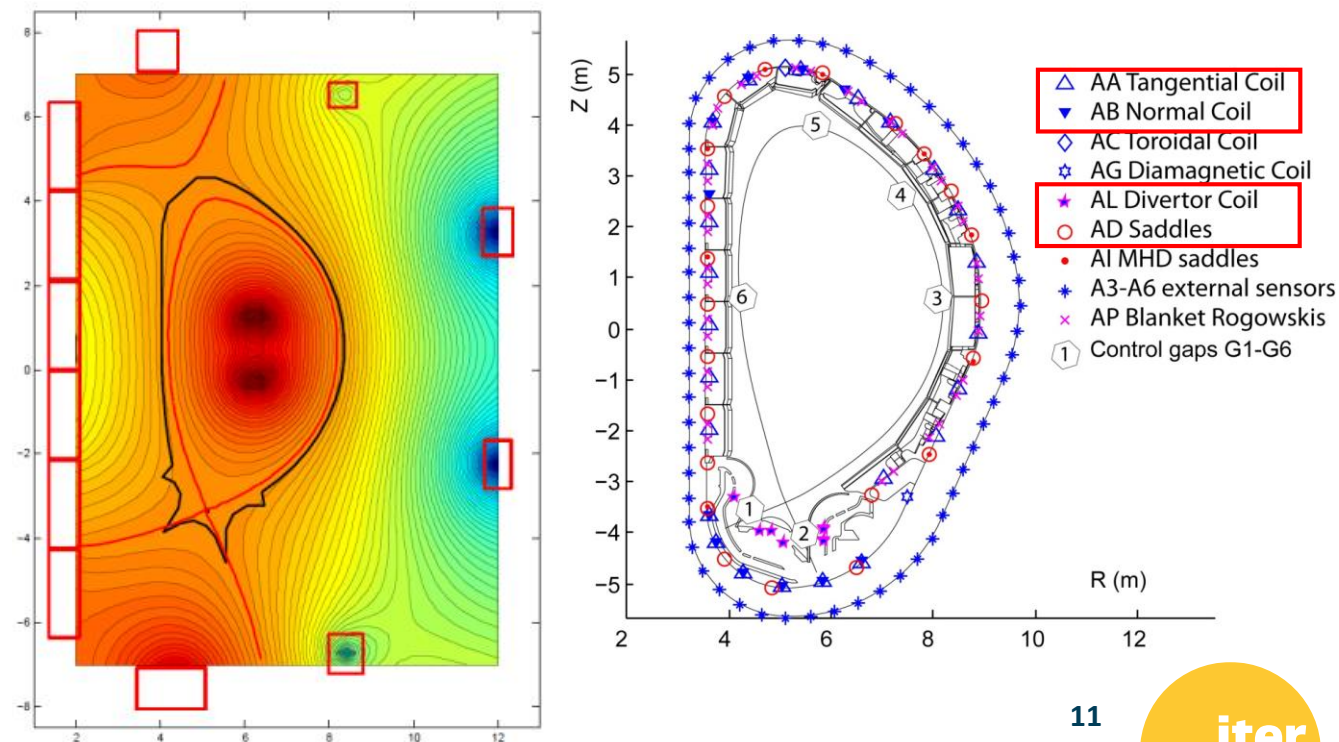

Magnetic diagnostic for plasma measurements:

measuring the plasma position and shape

The force balance of the plasma is sensitive to the vertical position of the plasma current centroid, Z_0 .

Z_0 is unstable. If nothing is adjusted, the plasma will accelerate up/down, leading to a disruption.
 ➤ Z_0 must be controlled.

It turns out that it is better to make a controller that attempts, to keep the vertical speed,

$$\dot{Z}_0 = \frac{dZ_0}{dt} = 0$$

For fast movements, the plasma initially moves more or less as a rigid body, so we could derive \dot{Z} from the shape measurements

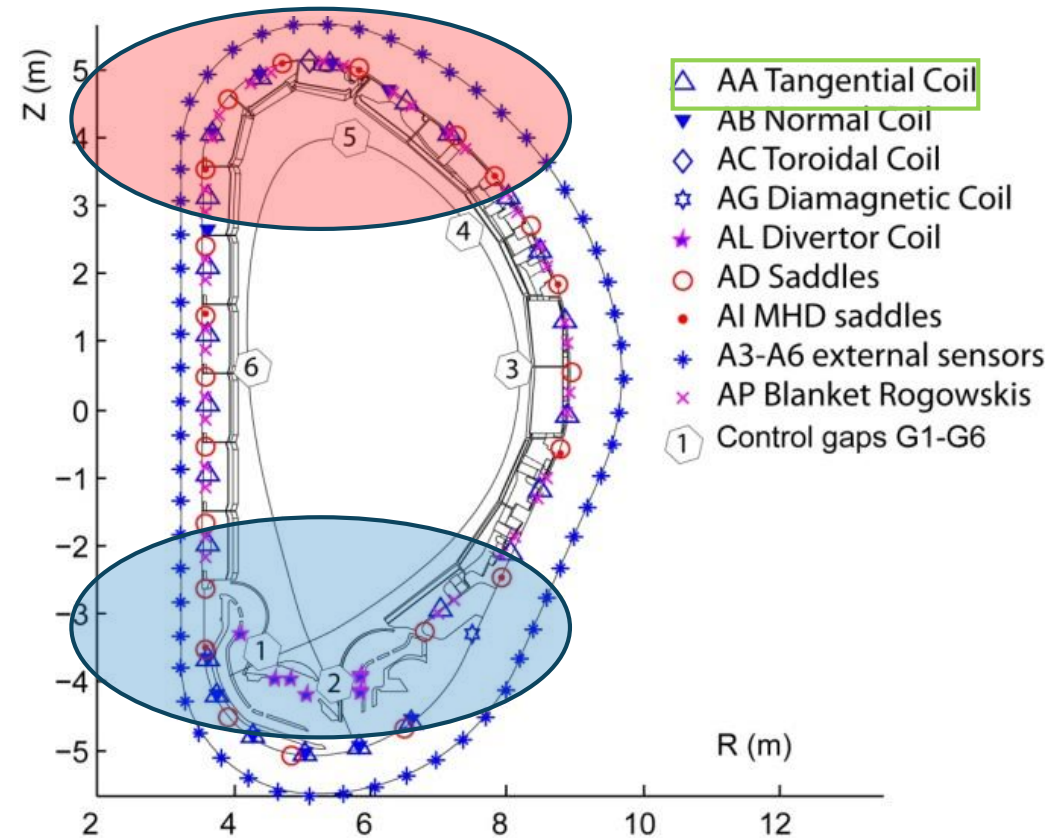

- inductive magnetic sensors measure the time-derivative directly
- Even better, a simple weighted sum of the magnetic field around the plasma gives a quantity proportional to Z_0
- For a movement upwards, field tangential to the vessel increases at the top and decreases near the bottom of the machine
- In principle, only a pair of pickup could do it (but higher perturbing modes are present)
- This is a faster process than the shape, measurements every 1 ms are required

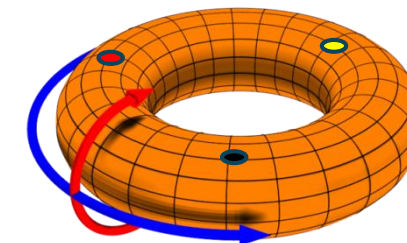
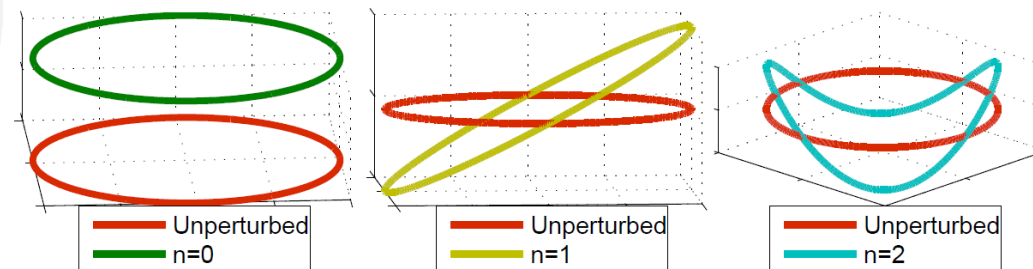

Magnetic diagnostic for plasma measurements: measuring plasma position and shape

Which sensor, where and how many

SHAPE

- 6 sets of 36 coils (tangential and normal to the vessel)
- 6 sets of ~22 saddle loops
- 6 sets of divertor sensors (coils and rogoswki)
- Effective redundancy is [x 6] for the saddles and [x 2] for the coils

SPEED

- The same 6 sets of coils in two independent triplets [x 2] redundancy
- Coils near the top and bottom of the machine most useful

Why so much redundancy?

- Saddle loops can't be maintained
- Pickup coils can be replaced only by first removing the blanket
- In-vessel coils also used for interlock measurements (higher availability requirements)

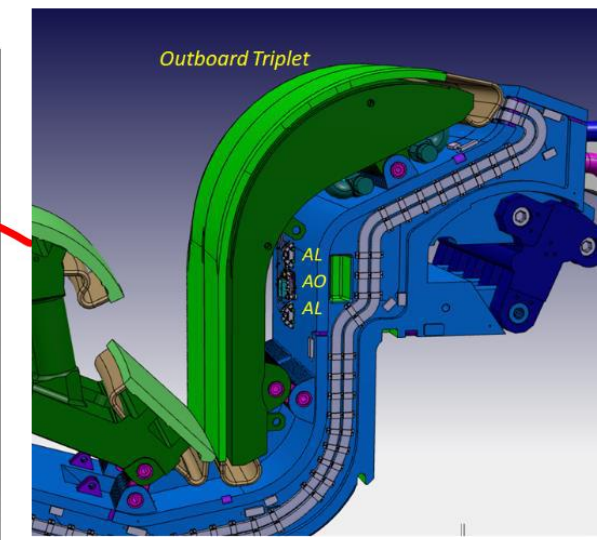
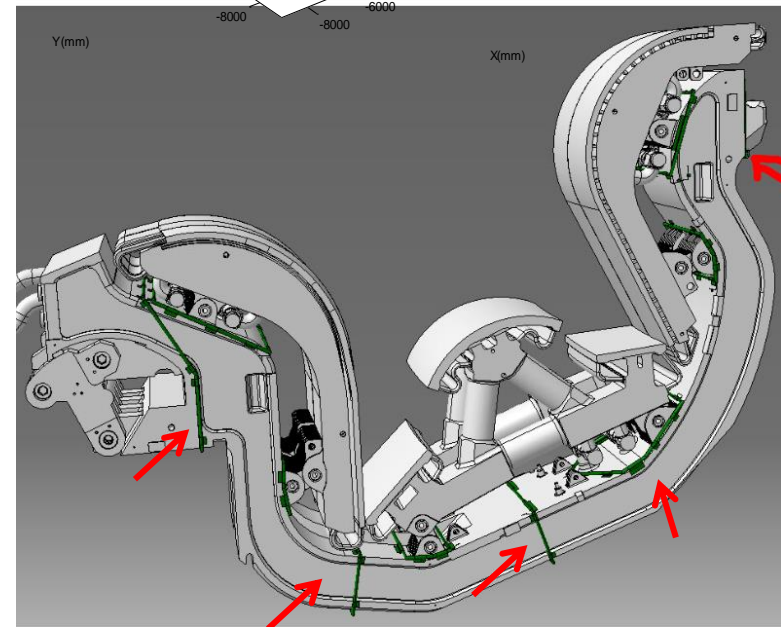
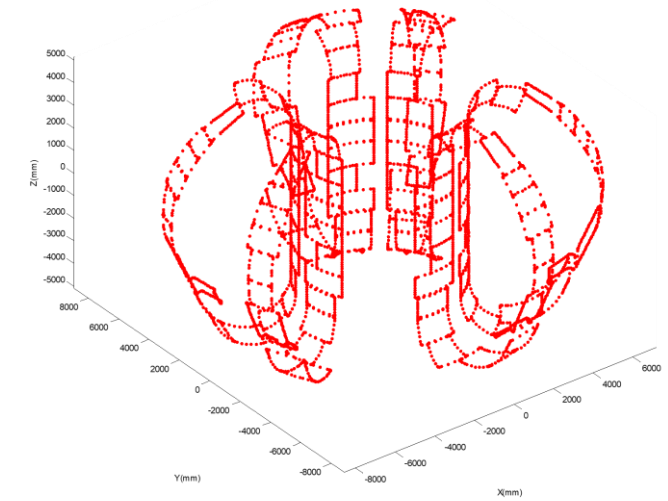
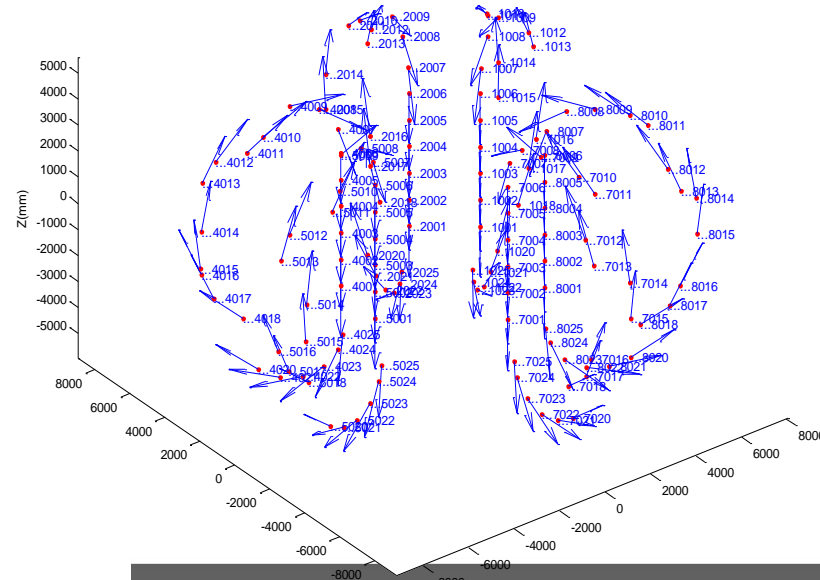

The Magnetics diagnostic zoo: Measure the plasma current

Fiber-Optic current sensors (FOCS)

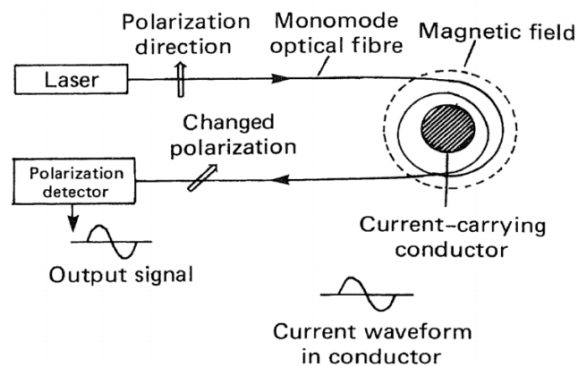

FOCS system already used at JET currently in use in the EAST tokamak

External continuous Rogowski coil
integrated in the Toroidal field coils case
2 Halves Rogowski loop

Working principle is the Faraday Effect:

- Polarized light is sent through an optical fiber around the vessel;
- a rotation of polarization is proportional to the enclosed current;
- the ITER total toroidal current is measured.
- FOCS measurement will be used as safety interlock measurement

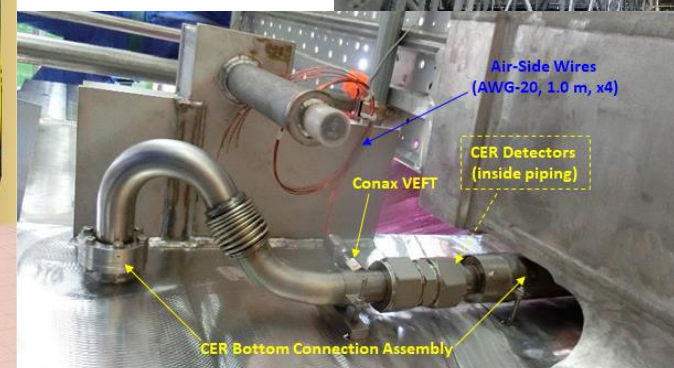
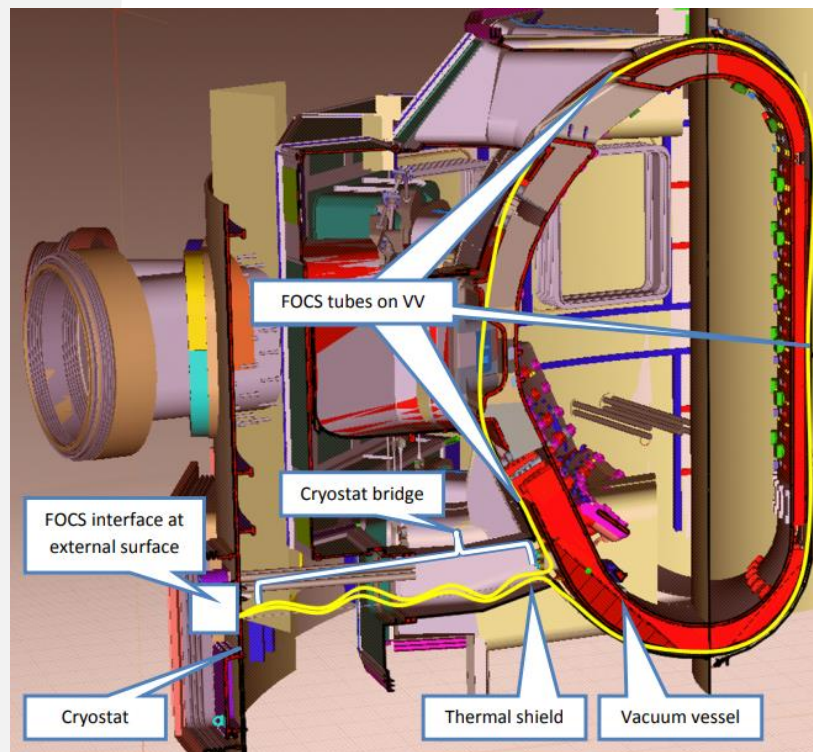

The Magnetics diagnostic zoo: making and installing saddle loops

- Loops made of Mineral insulated Cables (MIC)
 - Robust to handle
 - Good experience on many devices (JET, DIIIID, KSTAR, Tore-Supra, RFX)
 - Highly radiation resistant (used in fission plants world wide)
 - Wide temperature range
 - Outstanding UHV performance
- Distributed cooling to suppress thermoelectric effects and cope with the ECH strays
- Good quality seals
 - Miniature feedthroughs
 - Radiation hard materials
 - Able to cope with extreme temperatures (up to 1100 K)
- Robust, permanent connectors
- Precise metrology needed
- Exhaustive analysis against the ITER loads
- Main error sources
 - Thermoelectric effects
 - Aging (transmutation near blanket gaps, RITES)
 - From manufacturing defects (TIEMF)
- For large saddle loops, expected errors ~ 0.5 mT – good enough for field identification

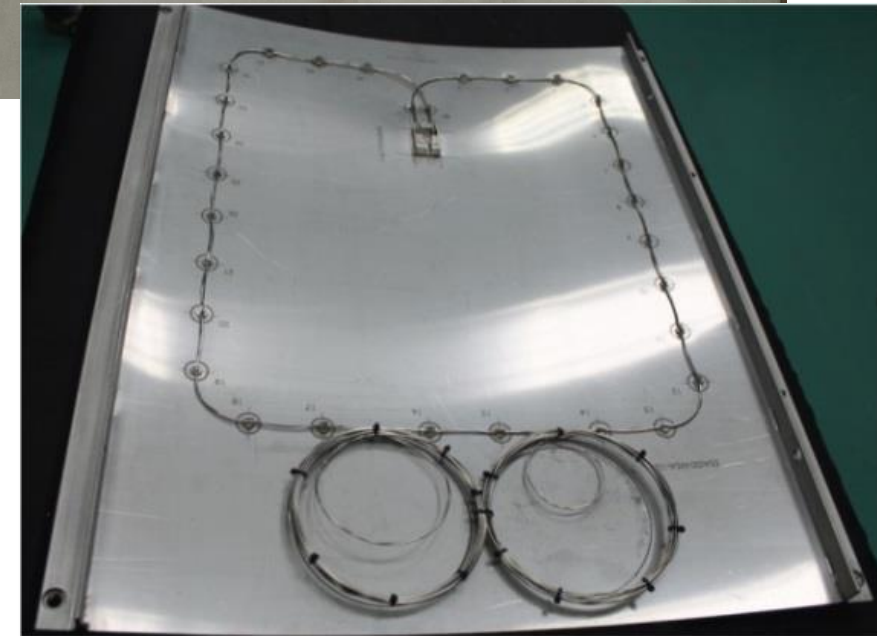
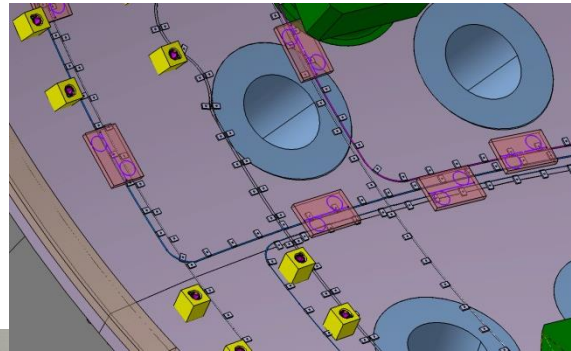

The Magnetics diagnostic zoo: making in-vessel coils

The same thermoelectric error sources, with RITES dominating in this case

RIEMF due to beta emission from activation products can also dominate

Ratio of effective area to length of cable is much smaller so coils are much more sensitive to radiation induced effects.

MITIGATION

Place carefully! ->hide

Material choices – but this may be difficult

Good cooling paths

Small sensors to reduce surface exposed

Protect from ECH -> cover

- Ultimately essential – so mounted on replaceable platforms much larger than the coil (from remote handling system)
- Small effective area (0.25 m²), so vulnerable to thermal gradients, nuclear transmutation and radiation induced conductivity and currents
- Stray ~DC voltage <500 nV for 1 h pulses
- Several rounds of prototyping
 - Irradiation, thermal tests , multiple supplier qualification
- Adopted Low Temperature Co-fired Ceramic (LTCC) technology with Ag windings
- Compact = small internal ΔT , easy to mount

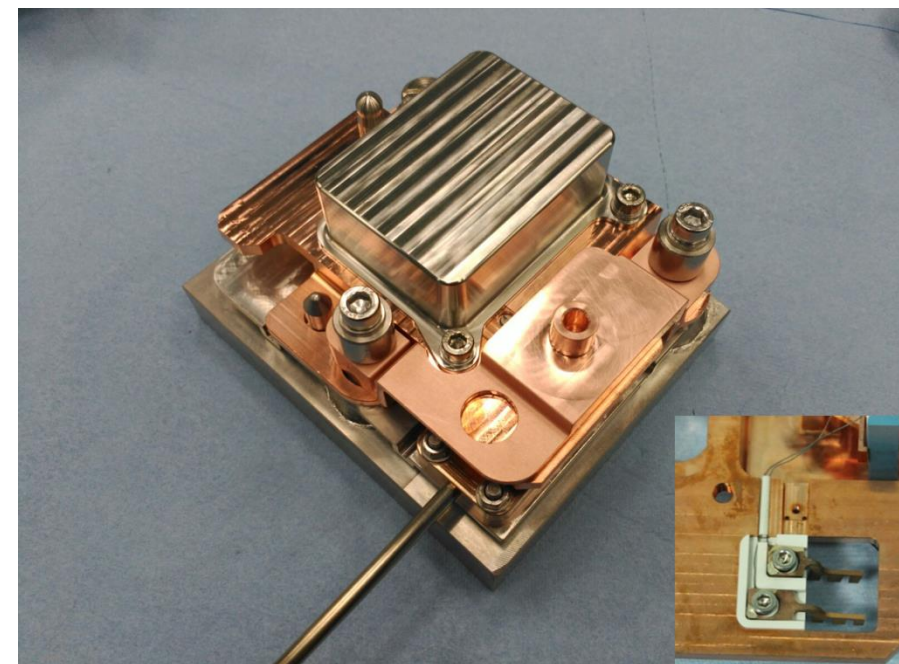
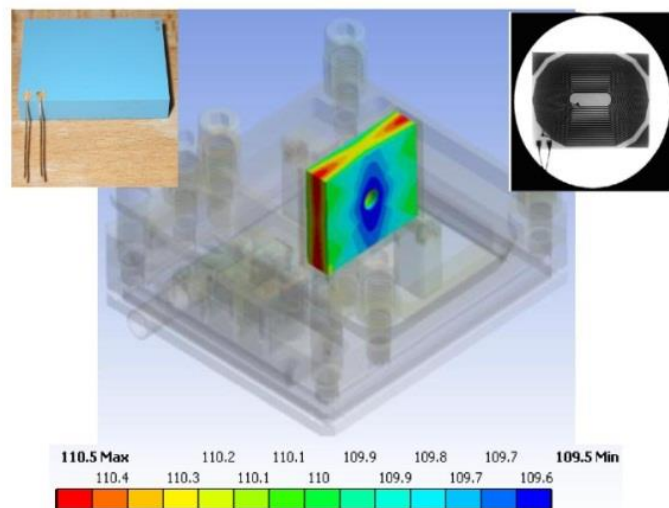

Platform
Prototype

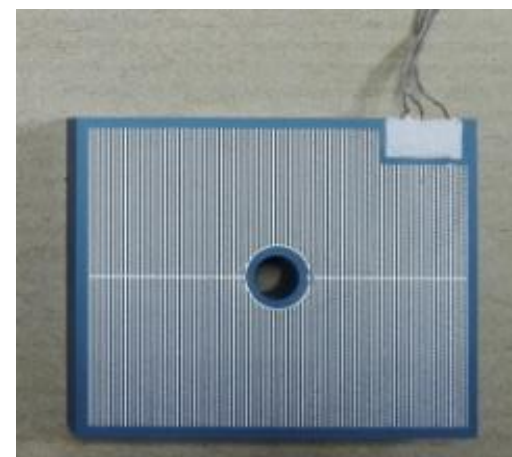
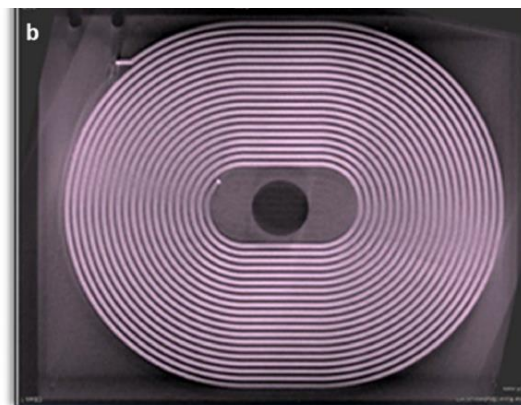

30-layer
Ceramic-metal
hybrid
Coil (LTCC),
30 x 40 x 8 mm³

The Magnetics diagnostic zoo: outer vessel coils

Sensors basically used to compensate and correct the internal measurements

- 60 positions tangential needed on three different sectors
- 60 positions radial needed on three different sectors
- Large (2 m² effective area, 2 kg weight) and robust (Inconel frames), with spring support from the vessel using welded bosses
- Not replaceable

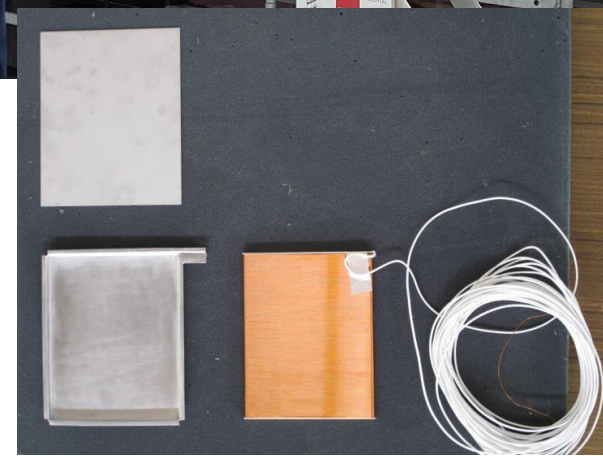
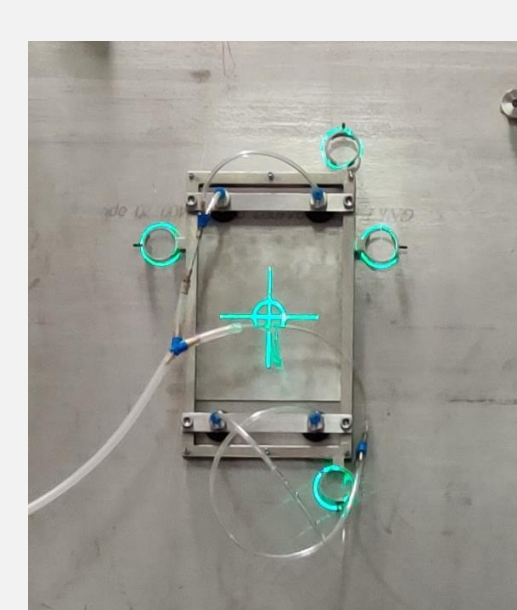
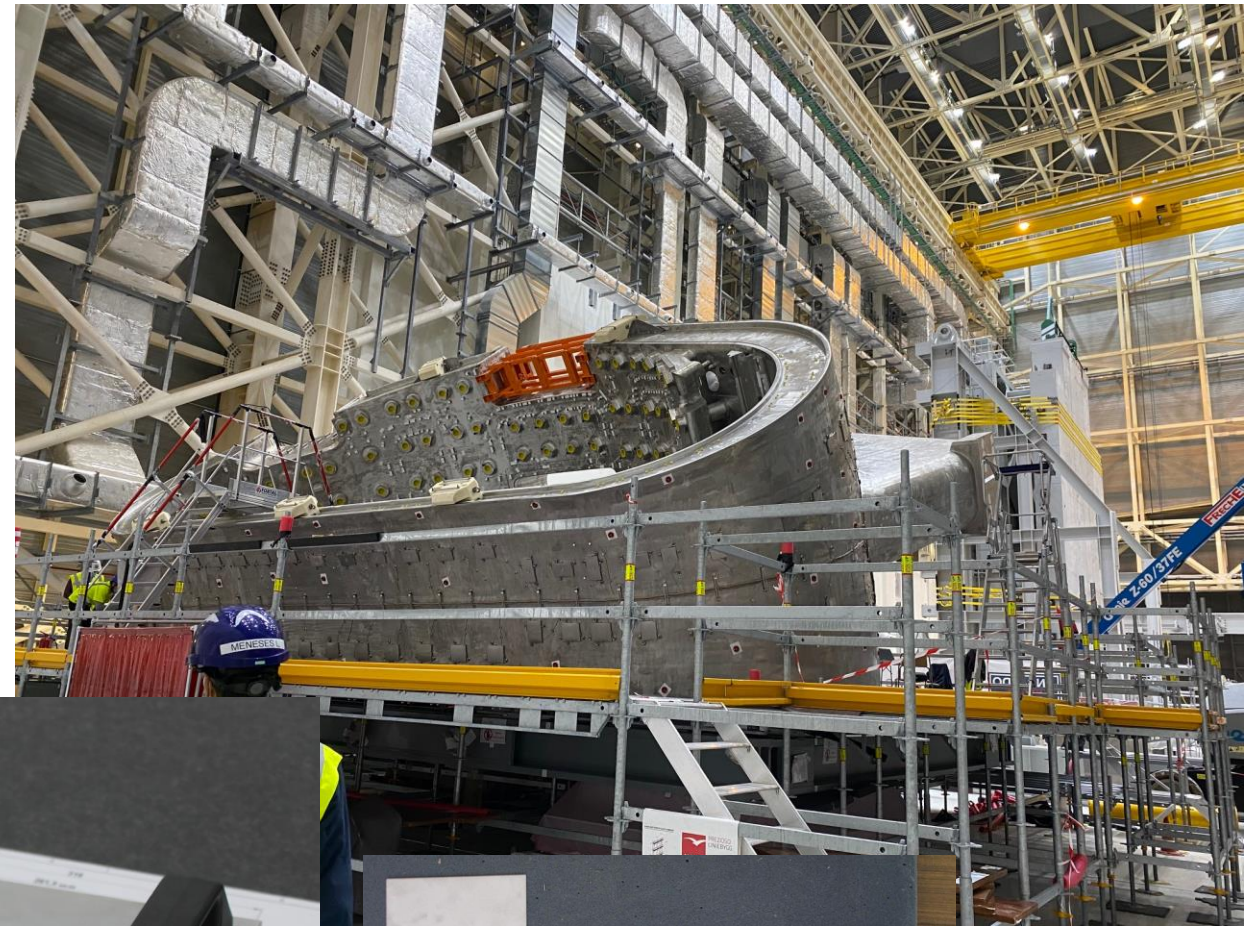

The Magnetics diagnostic zoo: Hall Probe sensors

Sensors basically used to compensate drift on long pulses (3600 s)

- 24 positions on three sectors.
- Holder contains radial, tangential and temperature sensors
- 60 positions radial needed on three different sectors
- Sensor tested for neutron irradiation and $\sim 200^\circ\text{C}$ baking temp
- Absolute calibration (field, angles and temperature)
- Require dedicated electronics (spinning current)



SENSOR PROBE

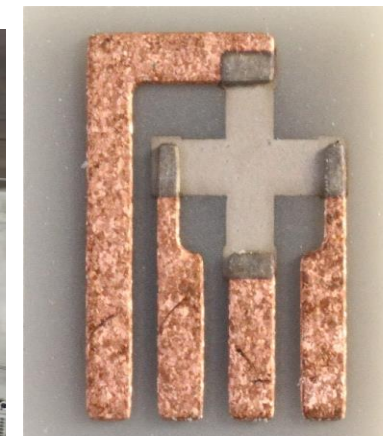

99% Al_2O_3 substrate

Bismuth sensing layer

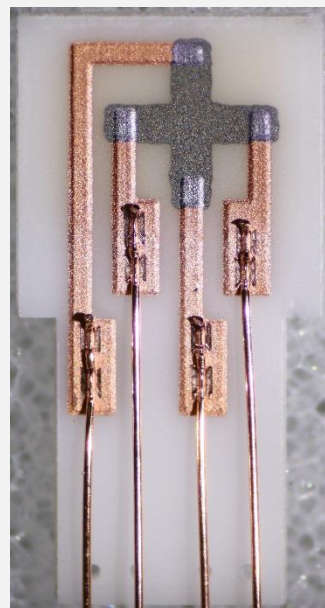

Ultrasonically bonded Cu wires

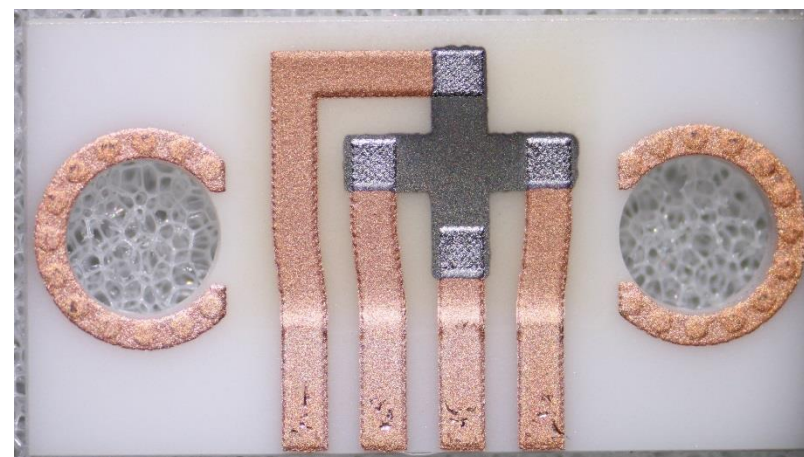

99% Al_2O_3 substrate 1 mm thick

Antimony sensitive layer

Tick printed copper metallization, thicker at contact pads

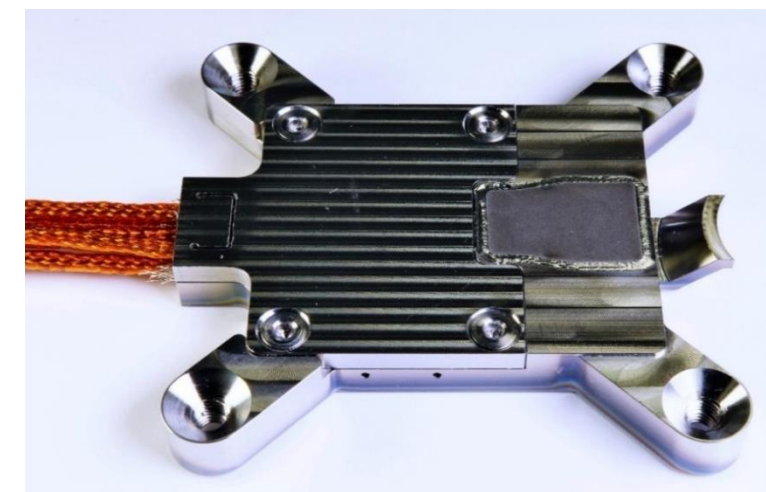

Courtesy of I. Duran (IPP Prague)

The Magnetics diagnostic zoo: possible developments

TPC (thin-film printing ceramic) is metallization technology for ceramic substrates. Ink-jet like technique is used to deposit copper ink onto ceramic substrate in predefined pattern followed by firing at $\sim 900\text{ }^{\circ}\text{C}$ in nitrogen.

Some features of TPC:

- Cu film thickness variable from $20\text{ }\mu\text{m}$ to $300\text{ }\mu\text{m}$ on a single ceramic substrate.
- Allows printing on nonplanar substrates.
- High thermal shock resistance ($>500\text{ }^{\circ}\text{C}$)
- Stacking and multilayered structures. Reliable technology for vias available.
- Extendable for printing other metals like Platinum
- No changes of microstructure due to irradiation



1st set of prototype coils:

- size: $15\times 40\times 6.7\text{ mm}^3$
- effective area: 0.02 m^2
- 8 layers,
- line/gap: 0.5 mm

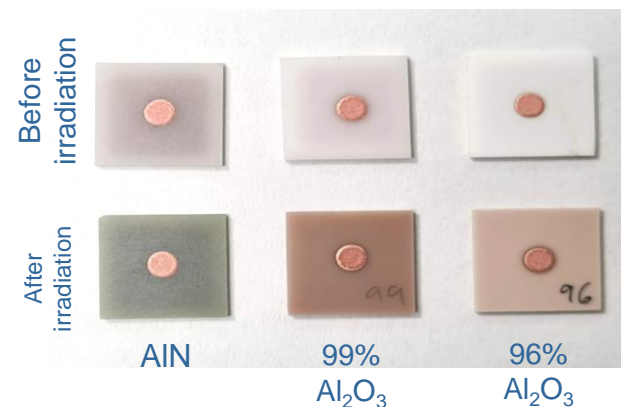

Courtesy of I. Duran (IPP Prague)

Rogowski coils in blanket and divertor structures

Some features of Rogowski coils:

- to be used to measure the halo currents, i.e. currents flowing outside the plasma through plasma facing components
- Around 30% of all the blanket panels are sampled (~250)
- 40 to 300 m of 0.5 mm diameter MI cable.
- Coils are CuPh brazed (reduced temp brazing).
- Each coils termination it is a vacuum seal -> need x-ray

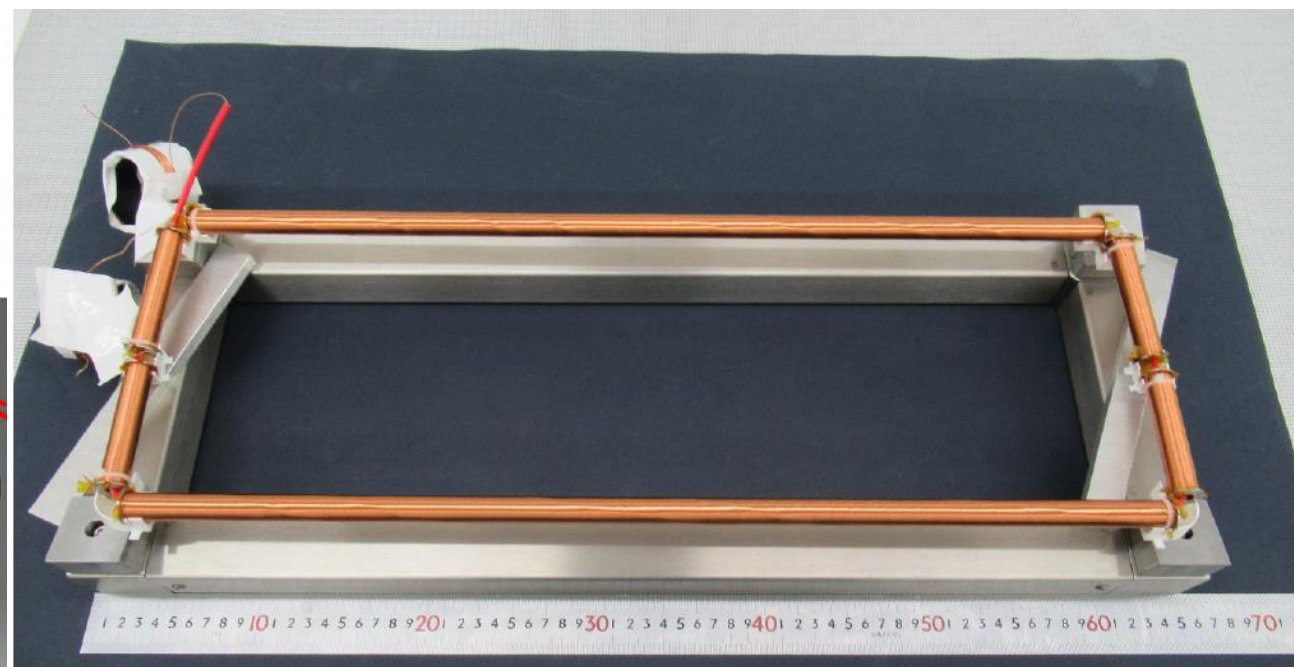
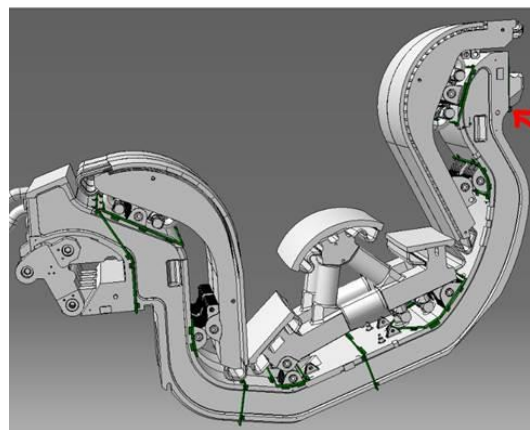
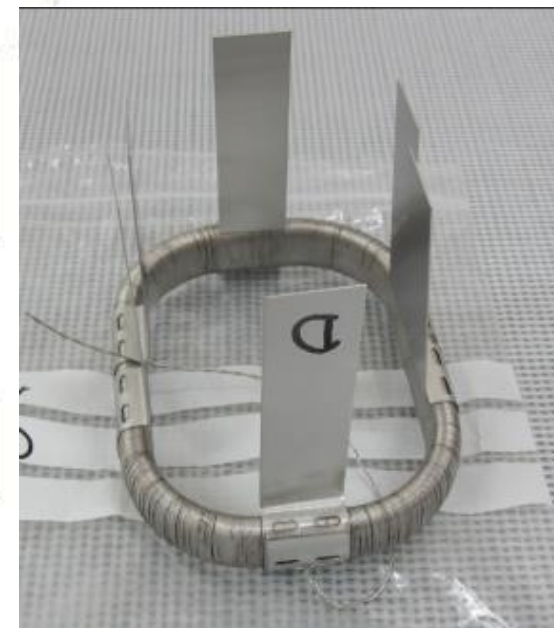
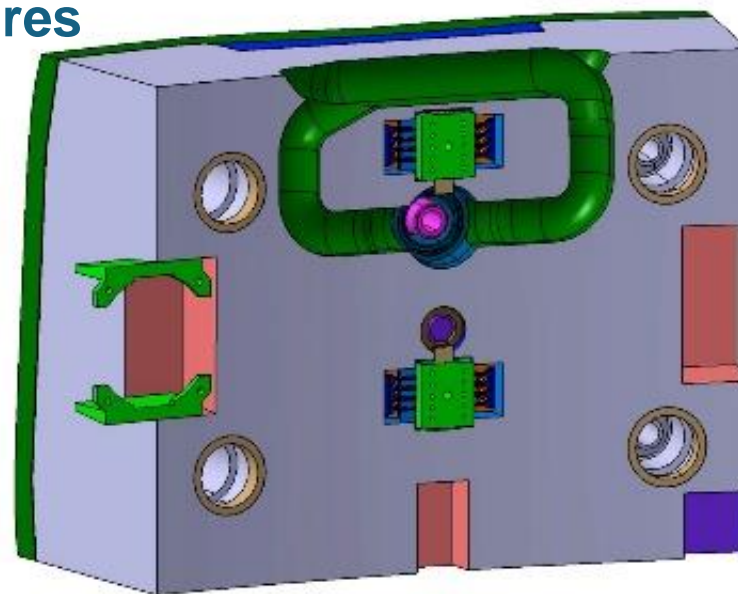

Magnetics electronics and software

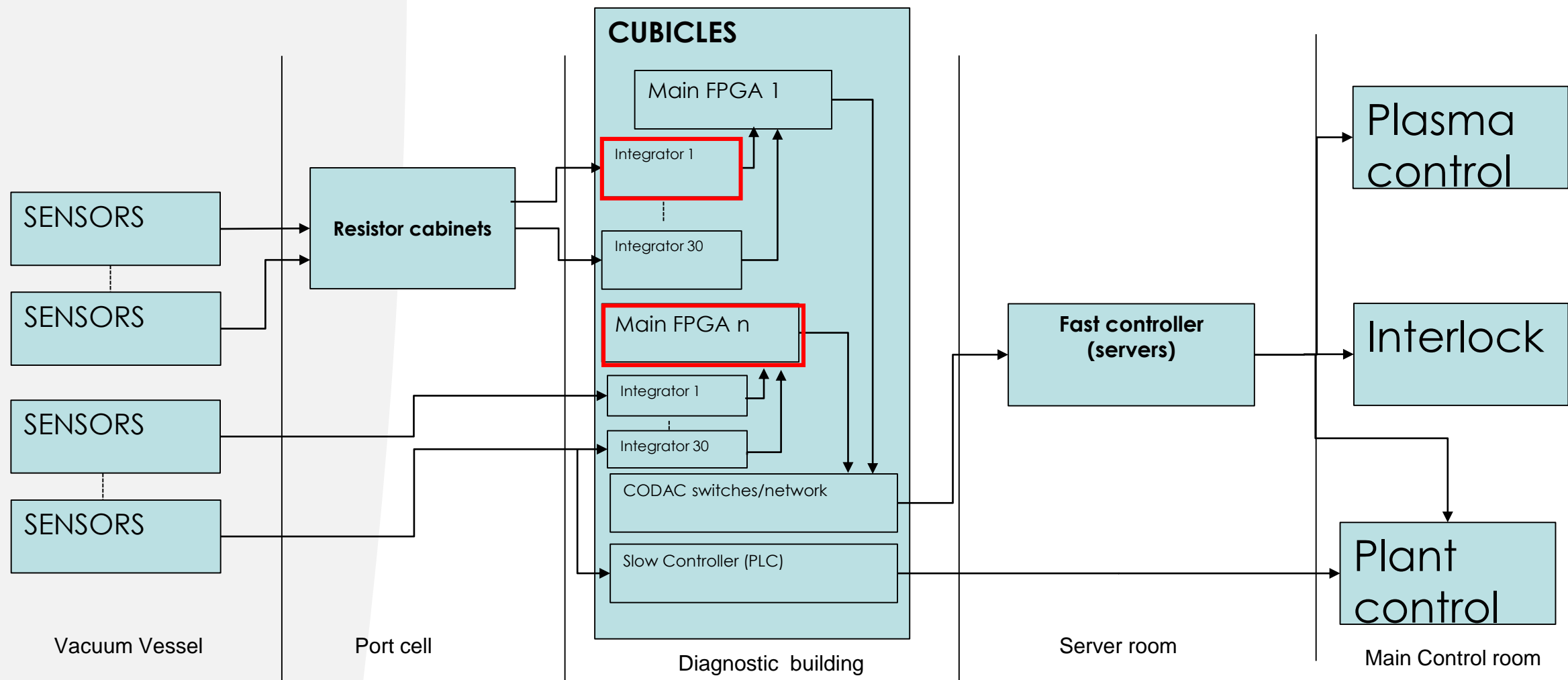

Magnetics electronics and software: Integrators

Some features of Integrators:

- Real time digital integration based on signal chopping concept
- Sampling rate 2 MSPS
- Dual channel proportional and integrated
- 18 bits ADC (one per channel)
- Analog front end adapted to the sensor characteristic impedance
- Tested on an operational tokamak

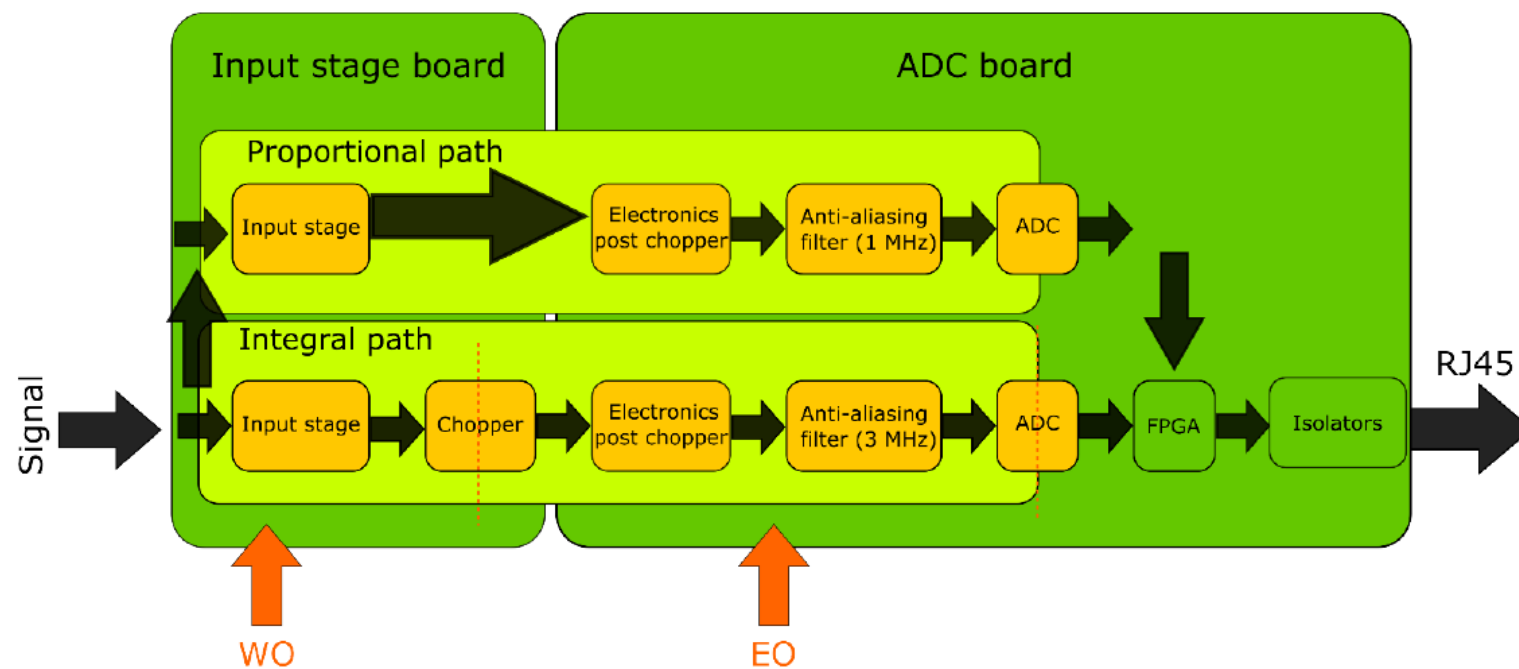
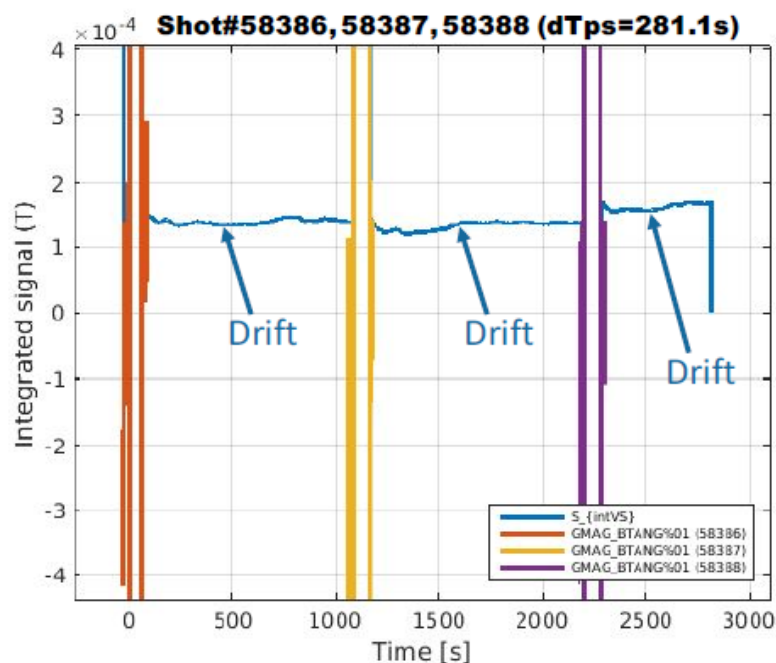

Courtesy of A. Neto (F4E)

Magnetics electronics and software: Main FPGA board

Some features of FPGA board:

- Based on Trenz Zynq UltraScale+ Multi processor
- Collect signals from a total of 30 integrators (60 channels)
- Elaborates signals (demodulation, decimation, time stamping)
- Aggregates data and compute some plasma parameters (i.e. Plasma current for interlock and vertical speed)
- Data streaming to real time network (10 kS/s *60 channels) and data archiving (2 MS/s *60 channels)
- Firmware implemented with real-time framework (MARTe2)

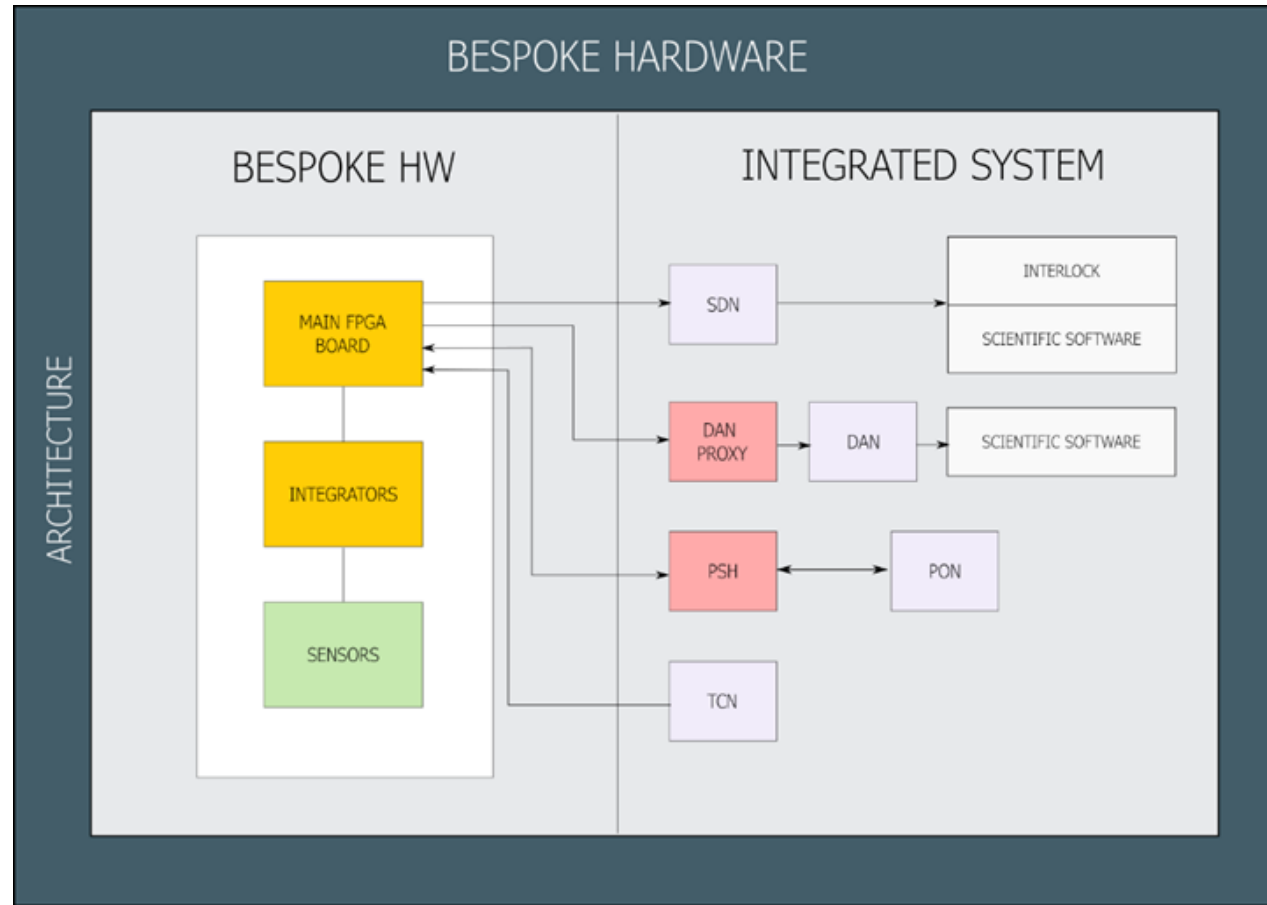
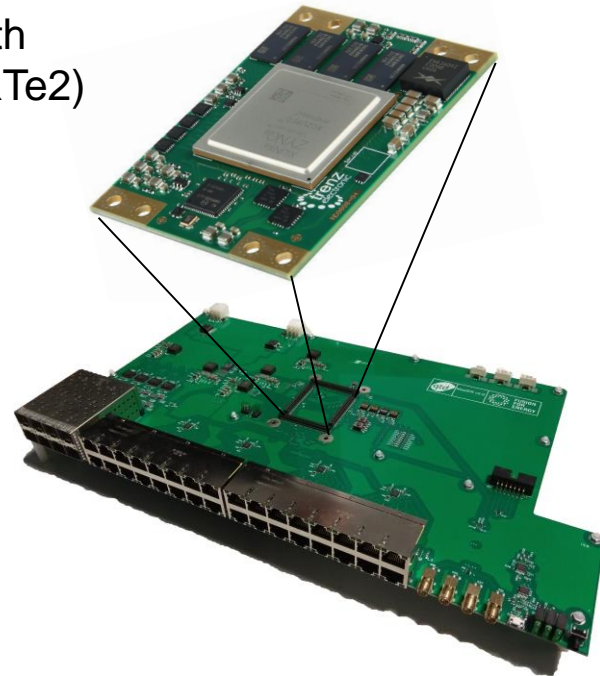

Courtesy of A. Neto (F4E)

Magnetics electronics and software: cubicles

- ~ 2000 integrators and 75 FPGA aggregators installed in 17 racks
- Performed functional tests and EMC tests
- 10 cubicles delivered to ITER and ready for installation

Network switches

Power supplies

Integrators

Main FPGAs

FPGA board to interlock

Acquisition Unit

PLC



Courtesy of A. Neto (F4E)

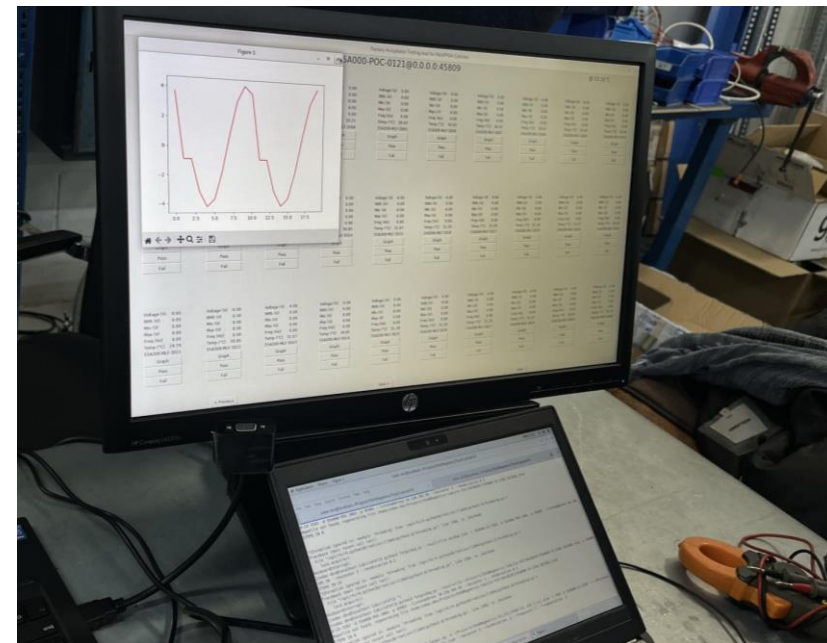

Magnetic diagnostic for plasma measurements: cabling

- Cabling sounds simple, but is challenging in ITER
 - High thermal loads and passive cooling
 - Stringent rules for attachment
 - A crowded environment
 - Wide range of clients: nA to 10s of A, nV to kV
- Cables are designed, routed and installed as a piping system of mineral insulated cables
- ~ 6000 cables, ~ 40 km and ~60000 clips
Each MI cable is “vacuum boundary”

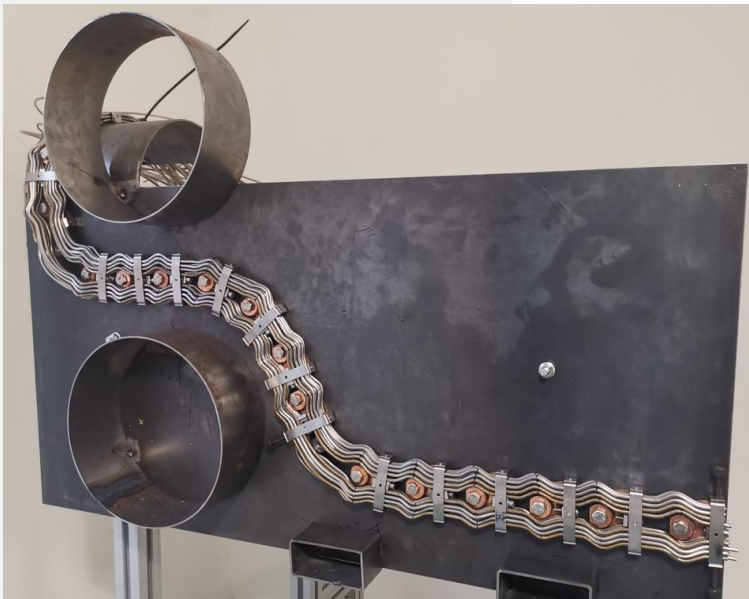
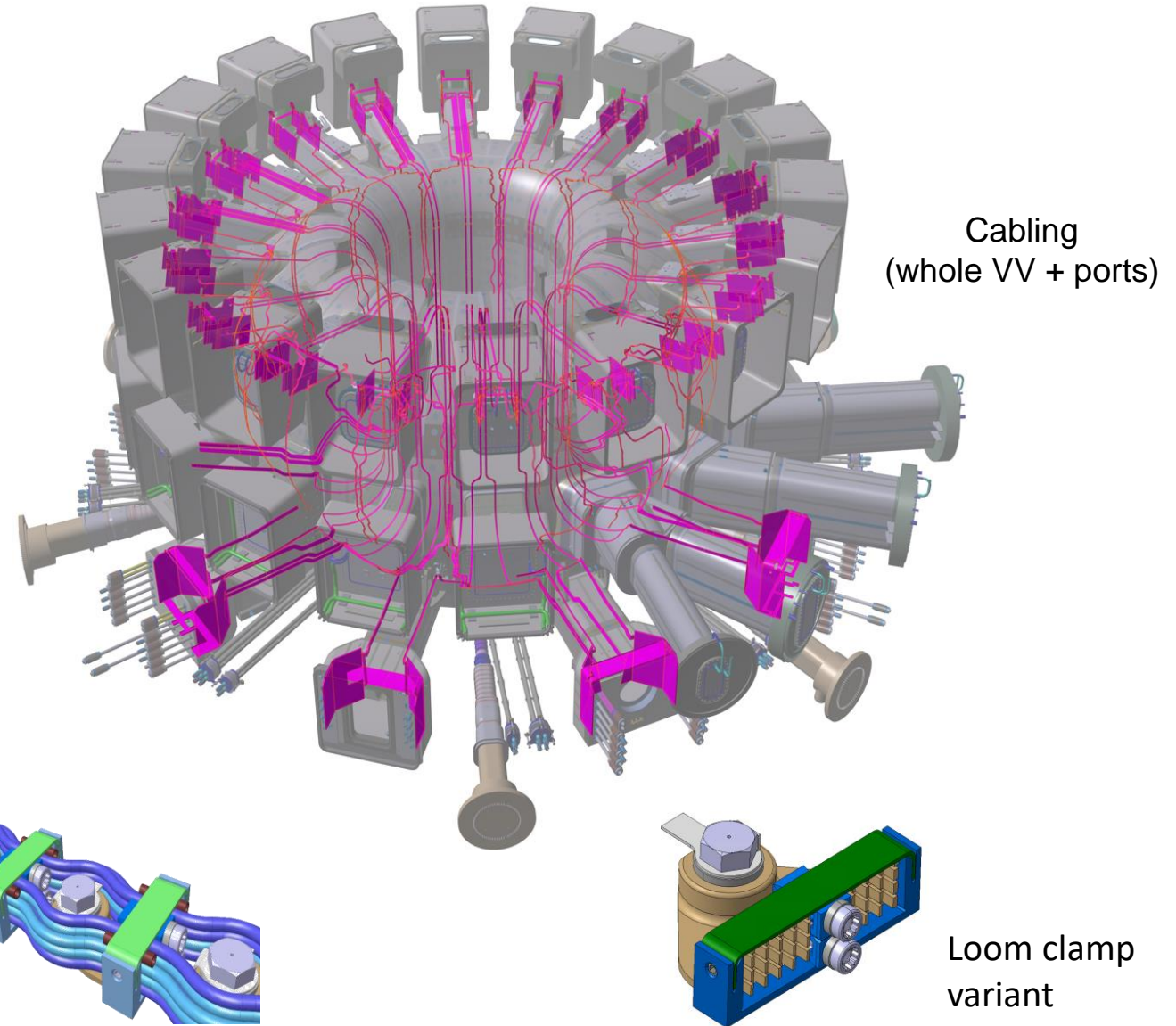

Magnetic diagnostic for plasma measurements: NMR toroidal field mapping

The First wall blankets needs to be aligned to the magnetic toroidal axis to prevent local heat loads on the first wall.

The geometrical axis can be different from the magnetic centre line due to several sources of errors like:

- Uncertainties in the TF winding pack inside the TF coil casing
- Uncertainties in the TF coils due to the behavior of coils supports during energization
- Possible deformation of the VV

The misalignment of the blankets modules with the magnetic field will cause a peaking of the heat load on the first wall

A set of 18 NMR giving absolute magnetic field measurement of the TF can provide the reference for the first wall alignment.

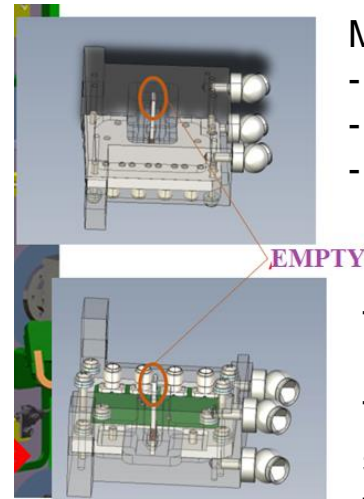
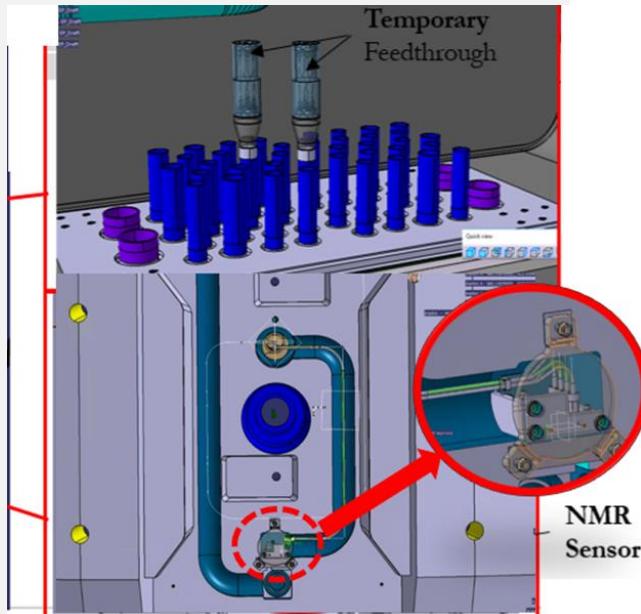

Main challenges:

- Gradient field
- Baking temperature (~200 degrees)
- Cabling: RF signals over mineral insulated cables and connectors

The contract with Metrolab was signed to start the manufacturing of the sensors
The Metrolab NMR sensors developed for ITER were successfully tested for resilience to radial gradient and for baking cycles up 210 degrees.

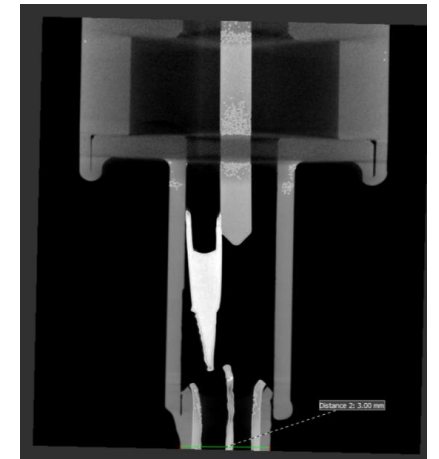

Courtesy of G. Severino

Conclusions

- ITER magnetic diagnostics is essential to measure several plasma parameters with interlock, safety and control functions
- ITER diagnostics for plasma shape and position use a mix of traditional approaches with some improvements:
 - Larger than average redundancy to cope with maintenance difficulties
 - Much better cooling to cope with nuclear and ECH heating in steady-state
 - Careful material selection to minimize thermoelectric effects, including those generated as the sensors age in the nuclear field
- Magnetic diagnostics provide as well measurement of the plasma vertical speed for control. Electronics noise will have to be carefully designed
- Electronics developed to cope with long pulse (drift) and large and distributed number of channels
- Main challenges to design sensors are the harsh conditions.
- Challenges for the cabling in – vessel and long distance is not negligible.

Acknowledgement

Thanks to the ITER Diagnostic team members and science department, the EU-DA team, and external laboratories involved in the systems mentioned in this presentation

Thank you!

A strong magnetic cage contains the hot plasma.

The magnetic structure is generated through a set of coils.

The plasma is then heated up to the desired level (~25-40keV in the core)

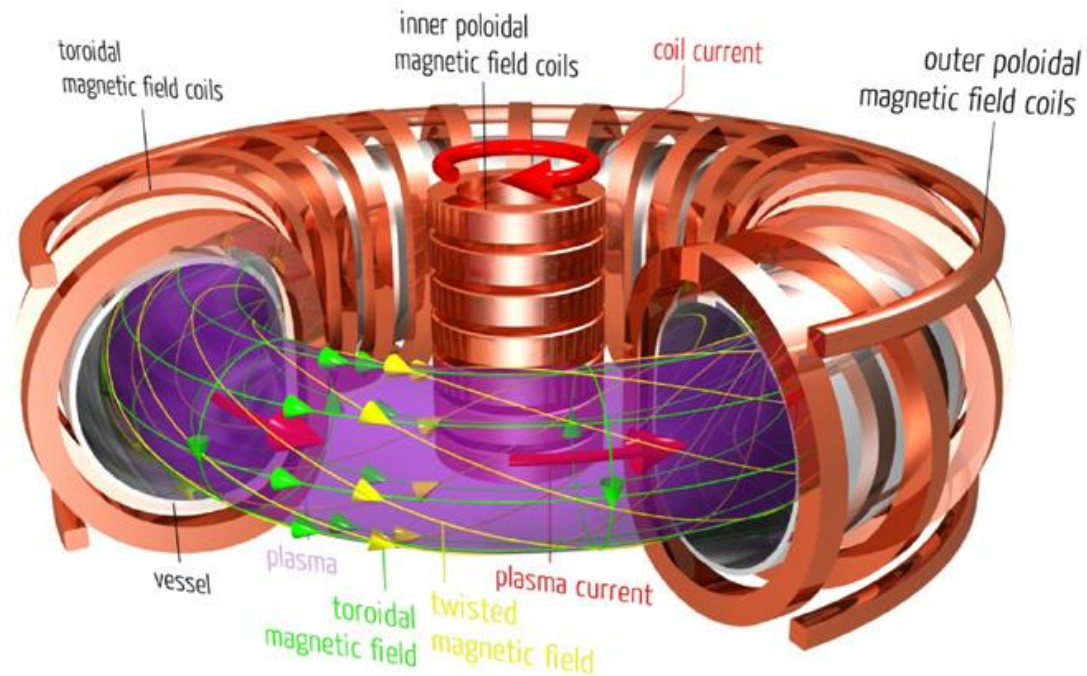

Magnetic confinement

