

Radiation hardness of Kapton in a helium atmosphere

Gian Luca Caratsch

LTPHD Seminar

19.06.2024

The Mu3e experiment

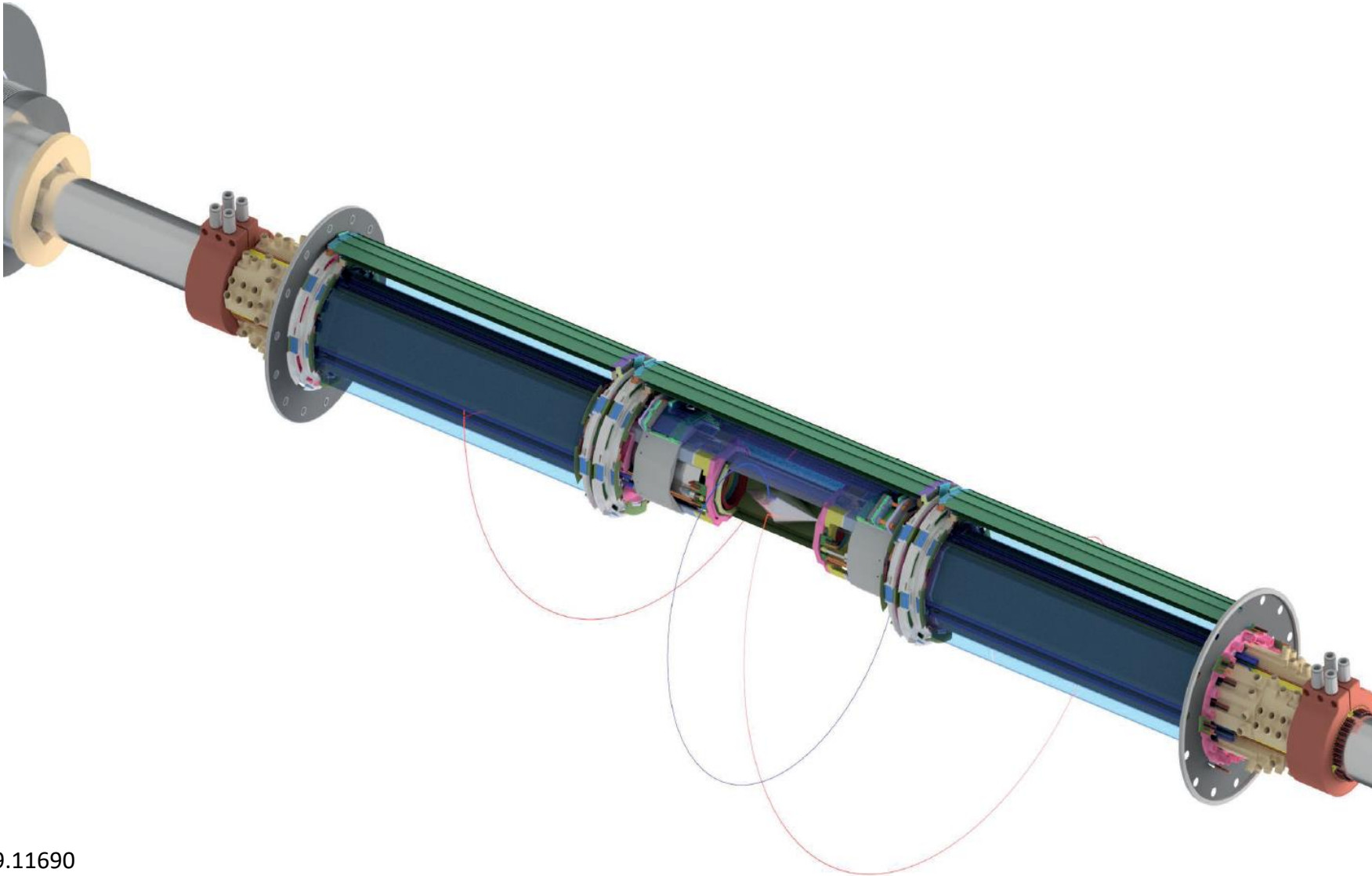

The background

- Observation: lepton family numbers (L_e, L_μ, L_τ)
 - Three lepton families

$$L_e = \sum (e^- + \nu_e) - \sum (e^+ + \bar{\nu}_e)$$

- **Almost** always conserved
- Are there any other L_i violating processes?

The background

- Observation: lepton family numbers (L_e, L_μ, L_τ)
 - Three lepton families
 - **Almost** always conserved
 - Are there any other L_i violating processes?

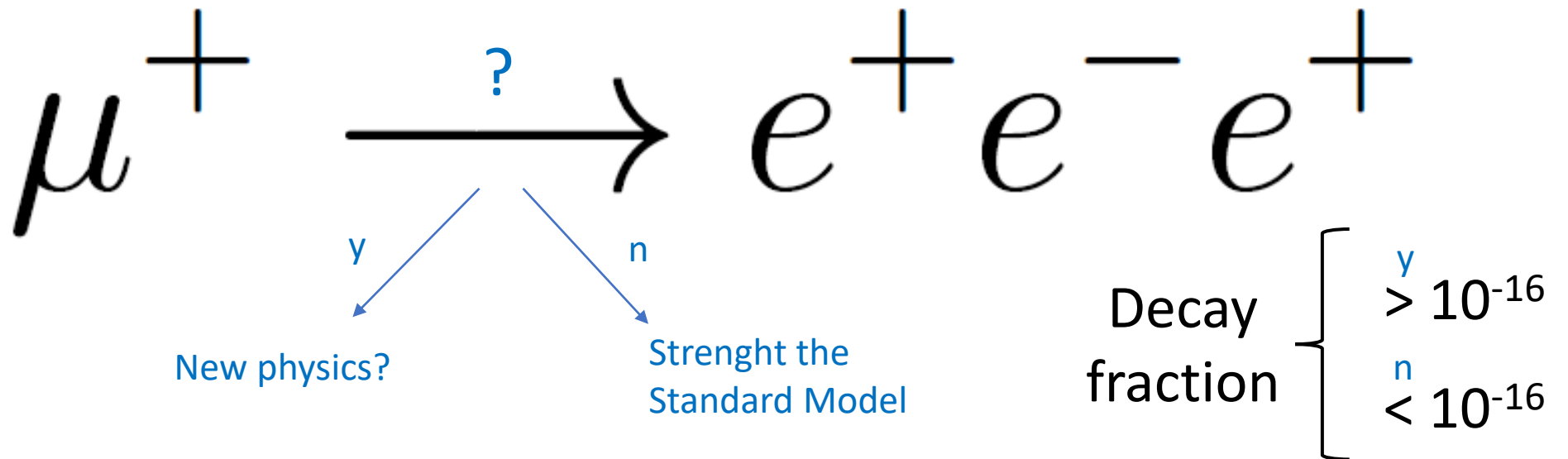

The Mu3e experiment

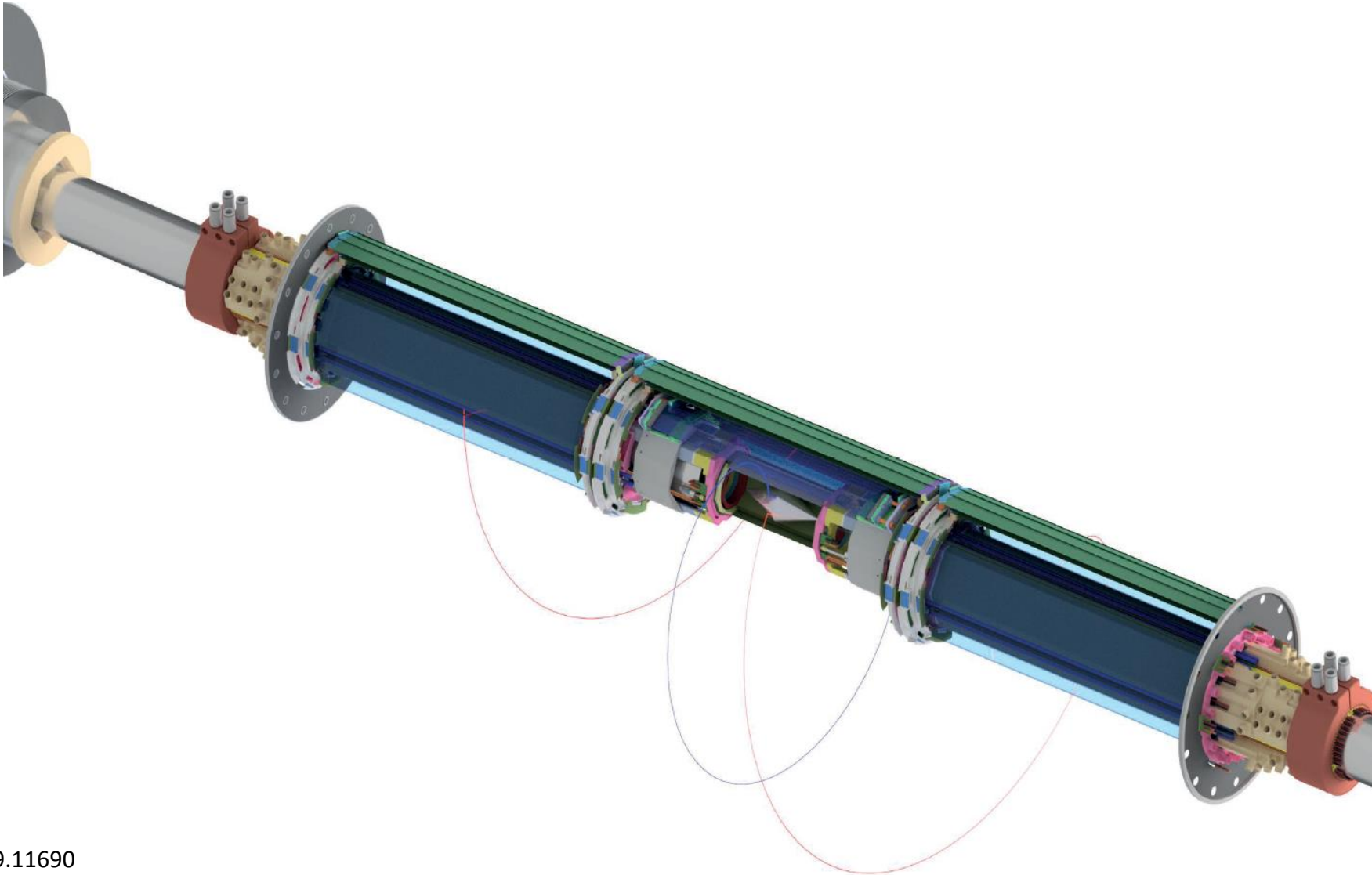

The Mu3e experiment

- Cooling of the sensors → Helium atmosphere
- Insulation and support structure → Kapton

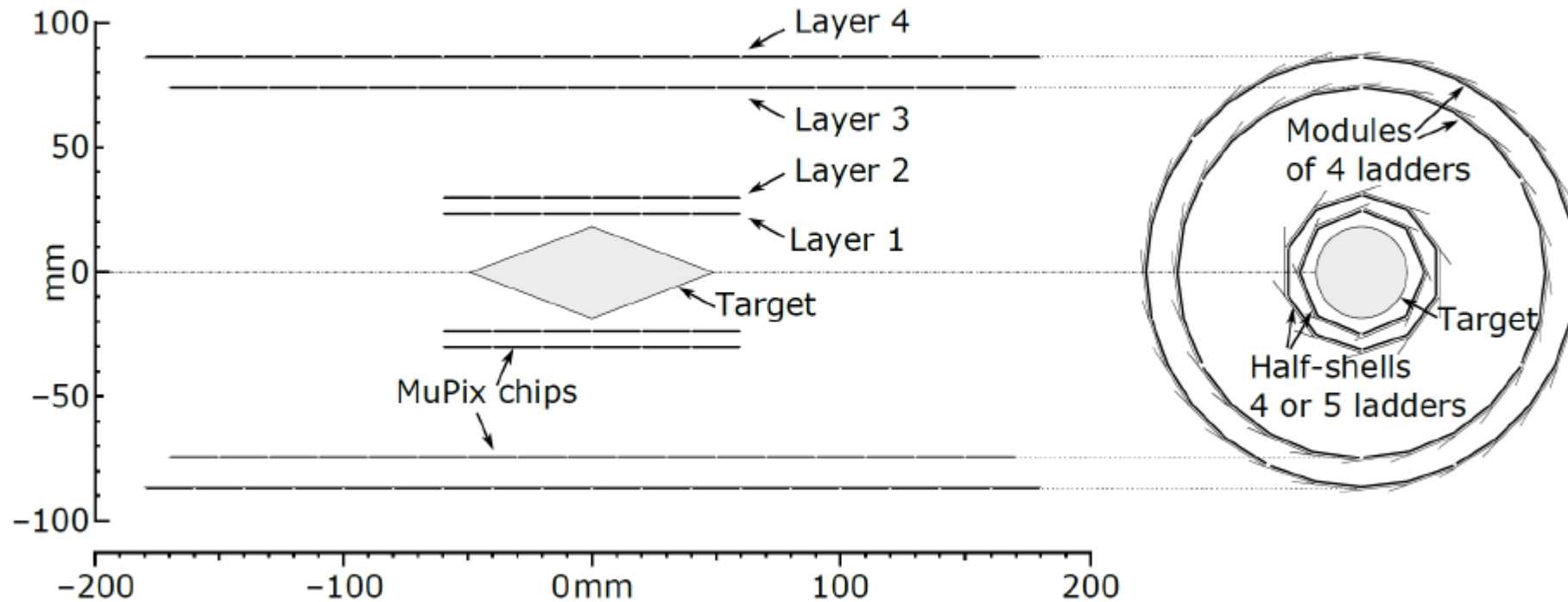

Kapton

- Synthetic polymer

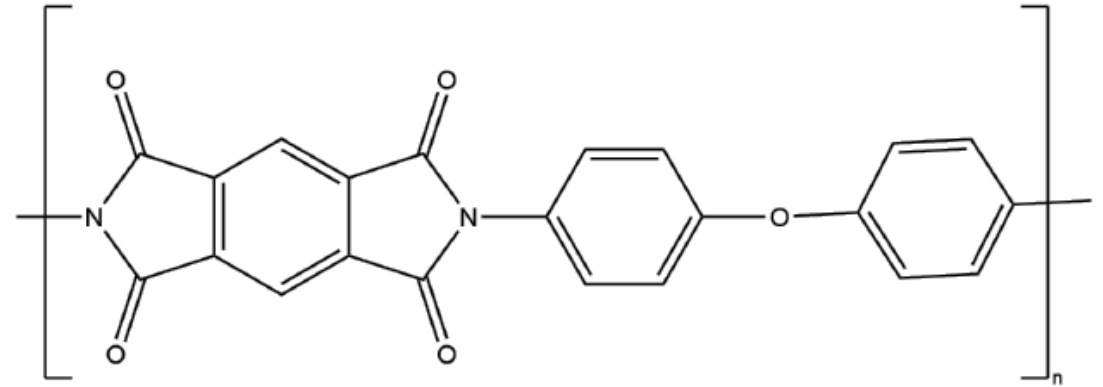

- Interesting properties for a detector
 - Rip resistance: 231 MPa at room temperature
 - Temperature resistance: -269°C to 400°C
 - Elasticity up to 70% at room temperature

- High radiation resistance
- Form conservation
- Low moisture absorption
- Dielectric constant lower than 3 → flexible printed circuits

Kapton experience

Kapton in the Mu3e experiment: a good choice?

- Phase I part:
 - $10^{16} e^+/\text{m}^2$
 - Often MeV positrons \rightarrow ionizing radiation
- Kapton in oxygenless atmosphere: a problem?

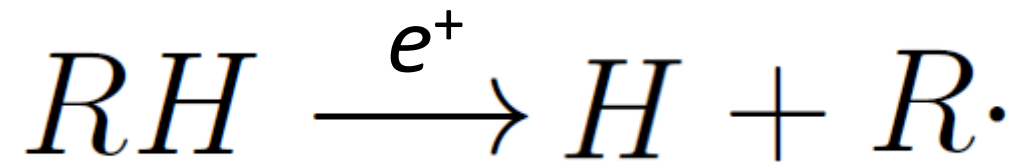

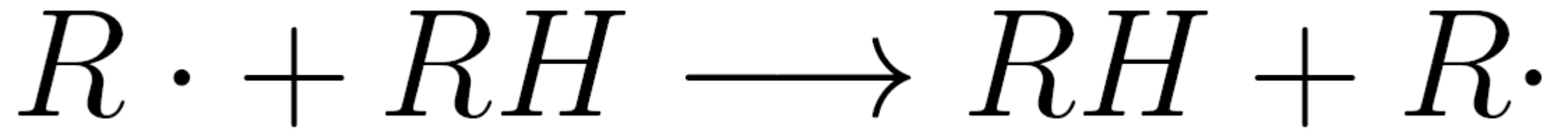

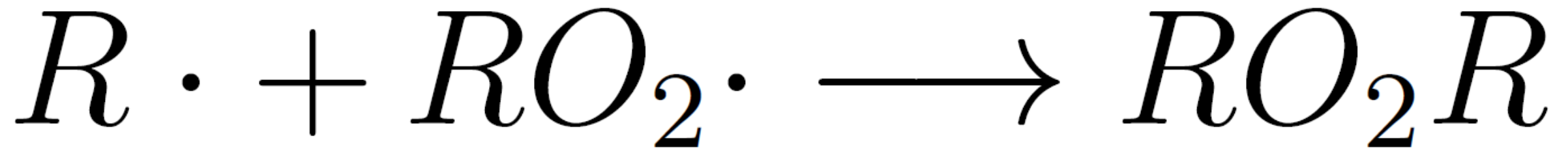
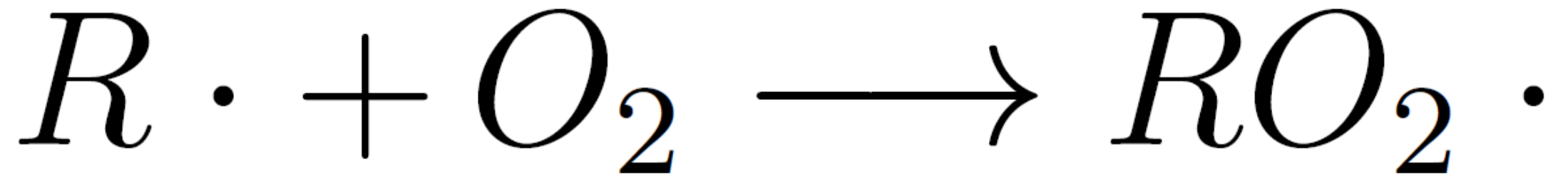

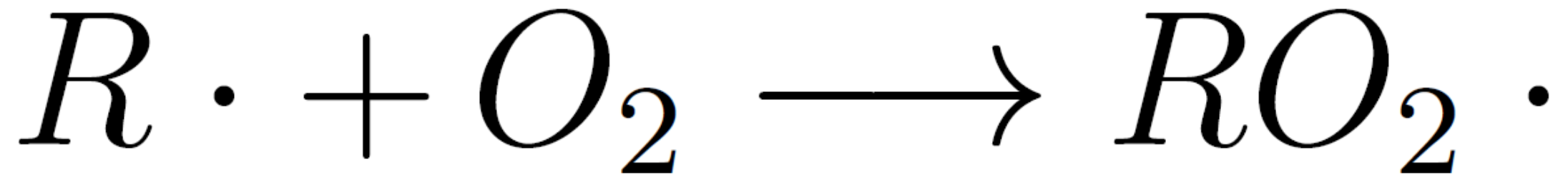

No oxygen around the Kapton layers in Mu3e!

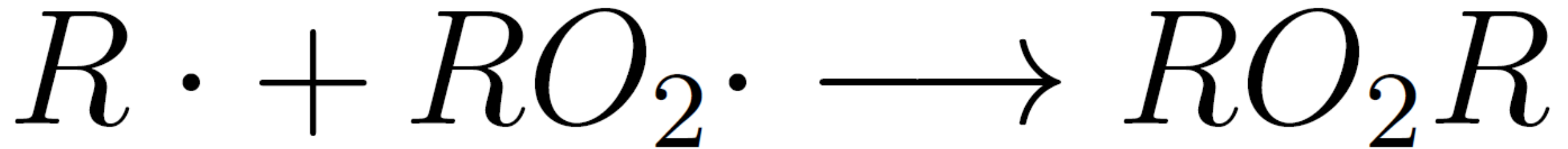

Design of a small experiment

- Solution: lets measure it!

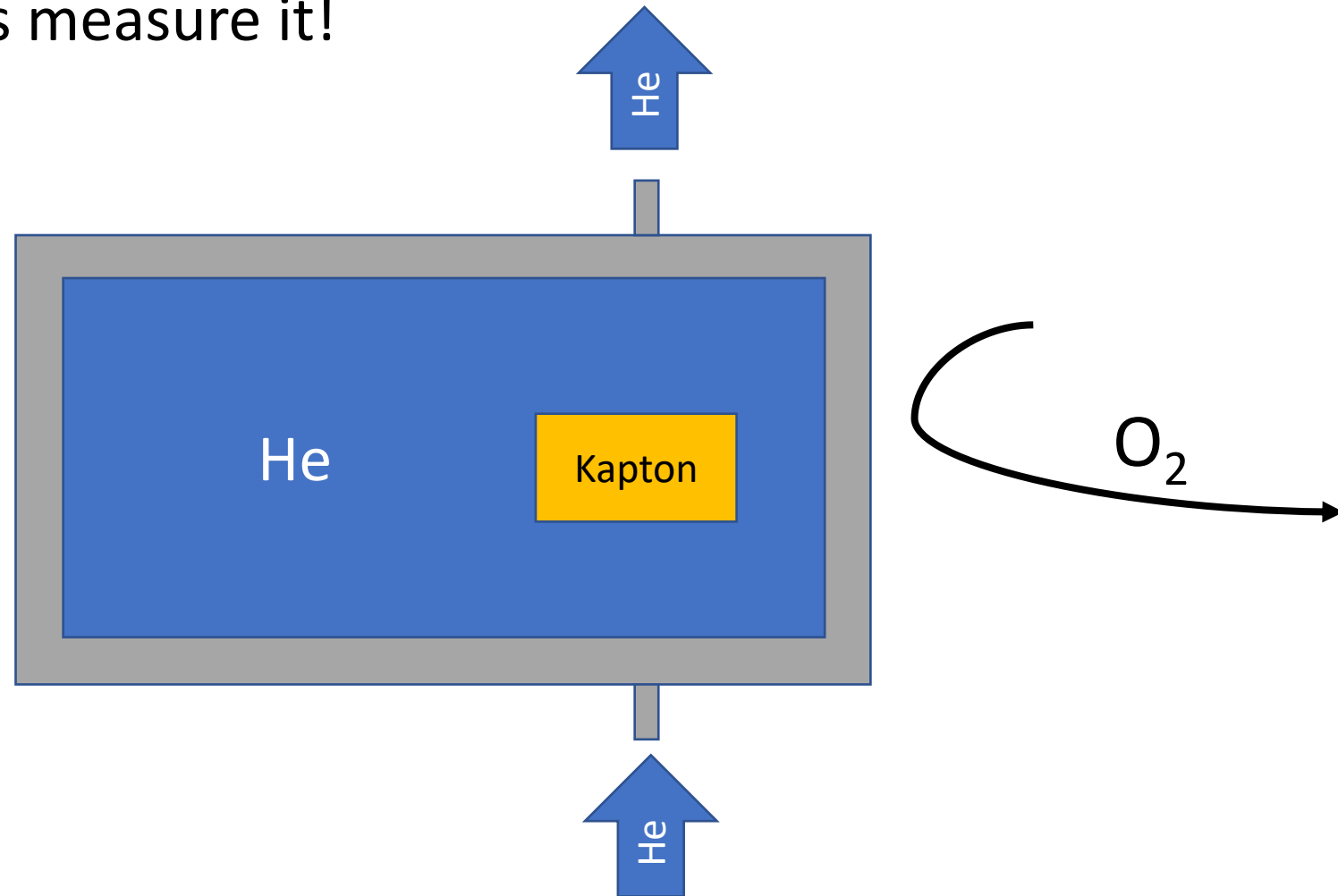

Design of a small experiment

- Solution: lets measure it!

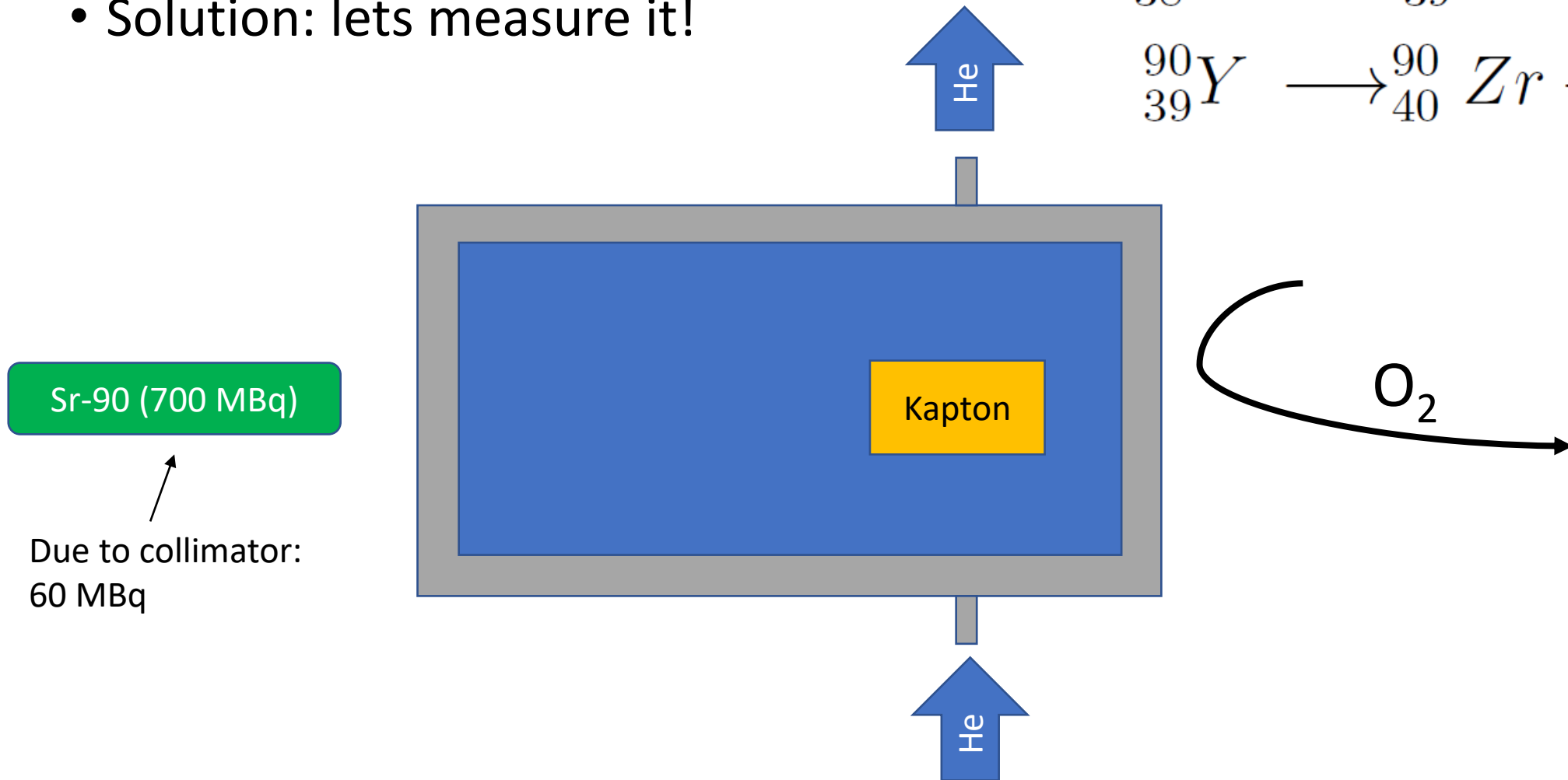
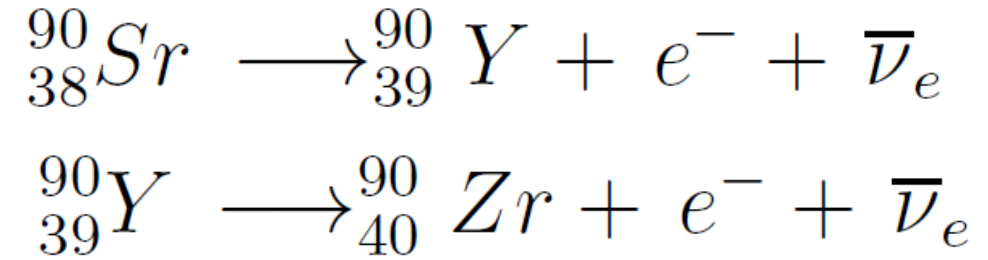

Due to collimator:
60 MBq

Design of a small experiment

- Solution: lets measure it!

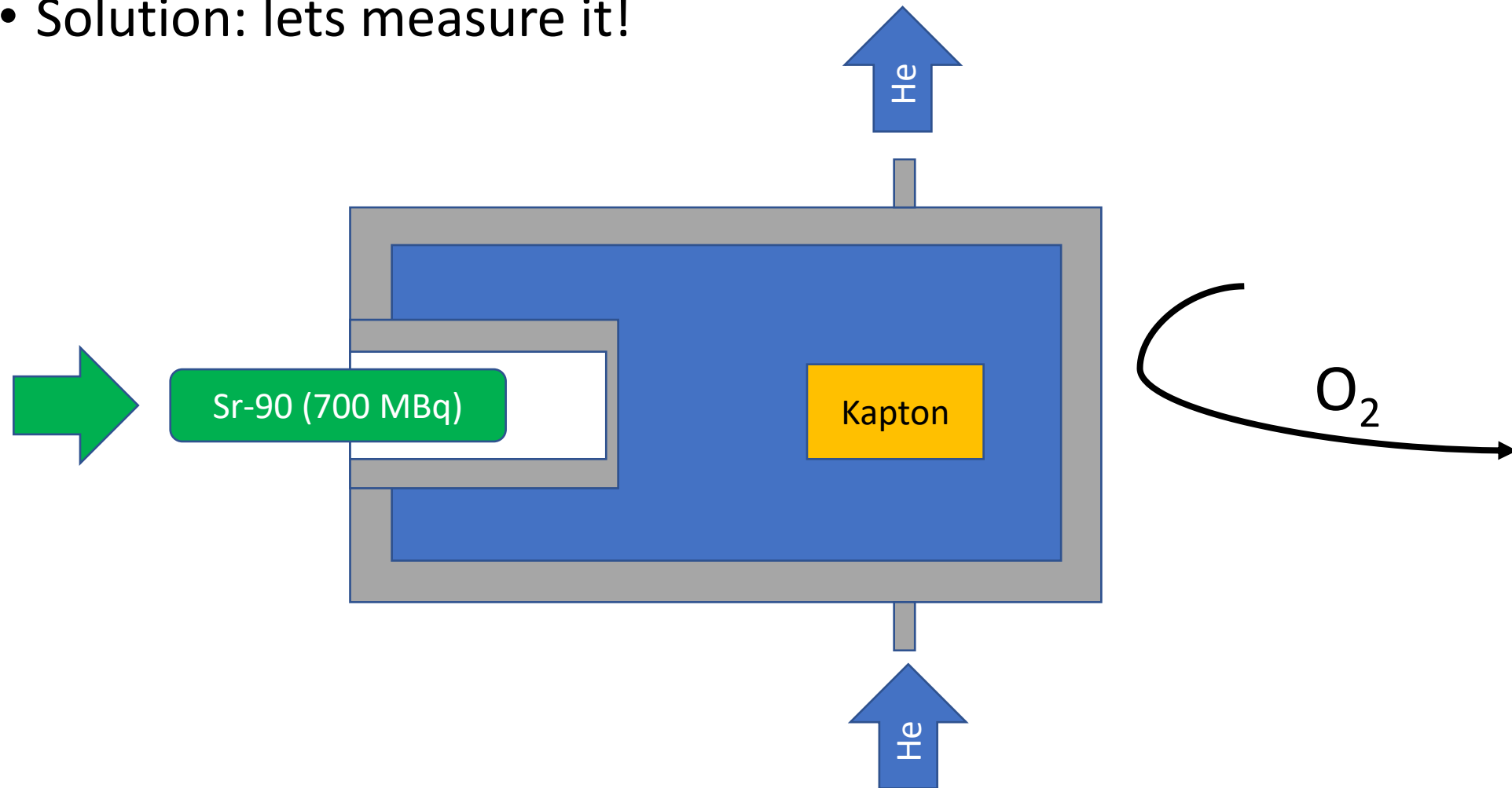

Design of a small experiment

- Solution: lets measure it!

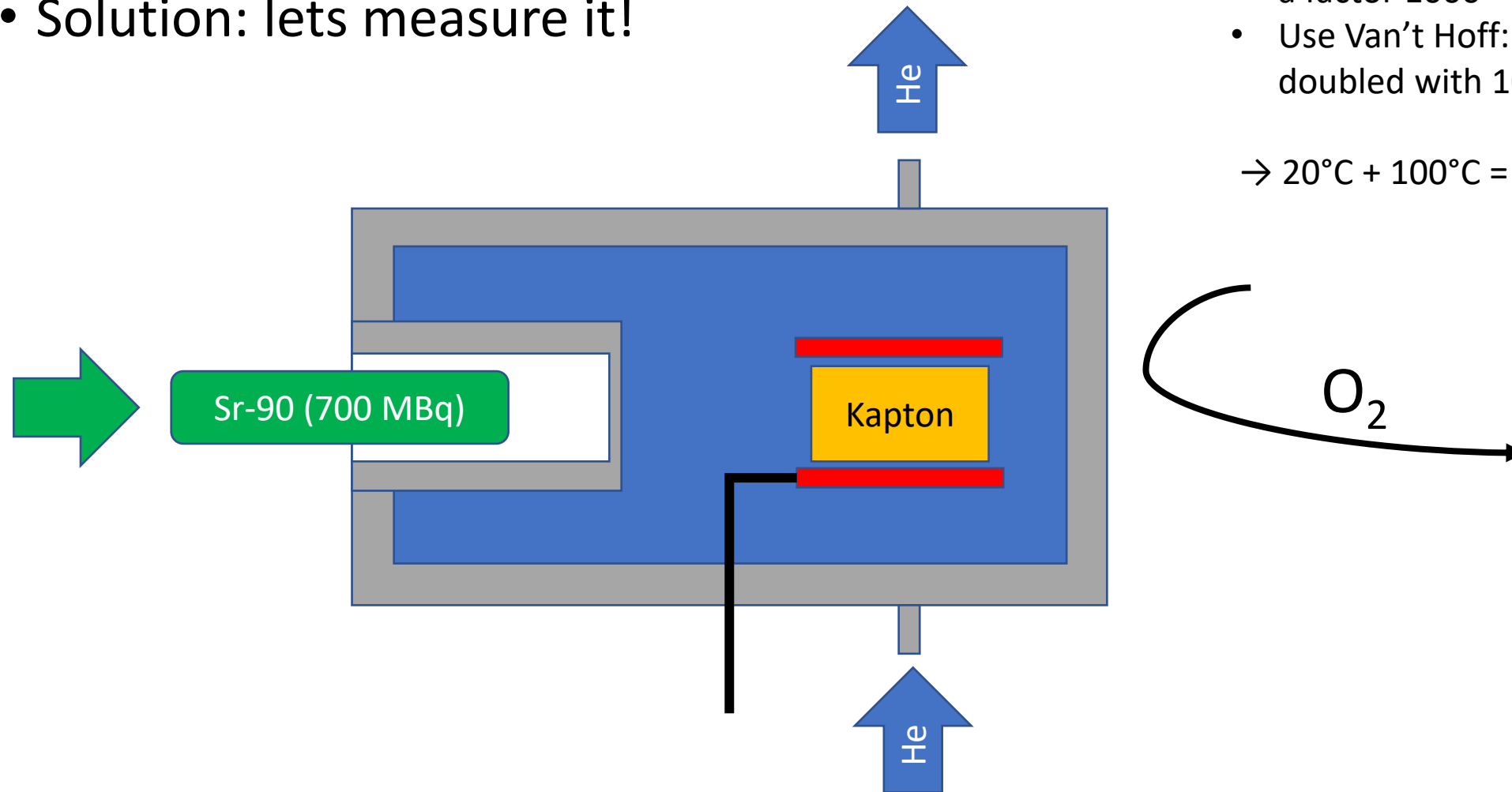

Heat control

- Accelerate radical diffusion by a factor 1000
- Use Van't Hoff: reaction speed doubled with 10°C more

$$\rightarrow 20^{\circ}\text{C} + 100^{\circ}\text{C} = 120^{\circ}\text{C}$$

Final design

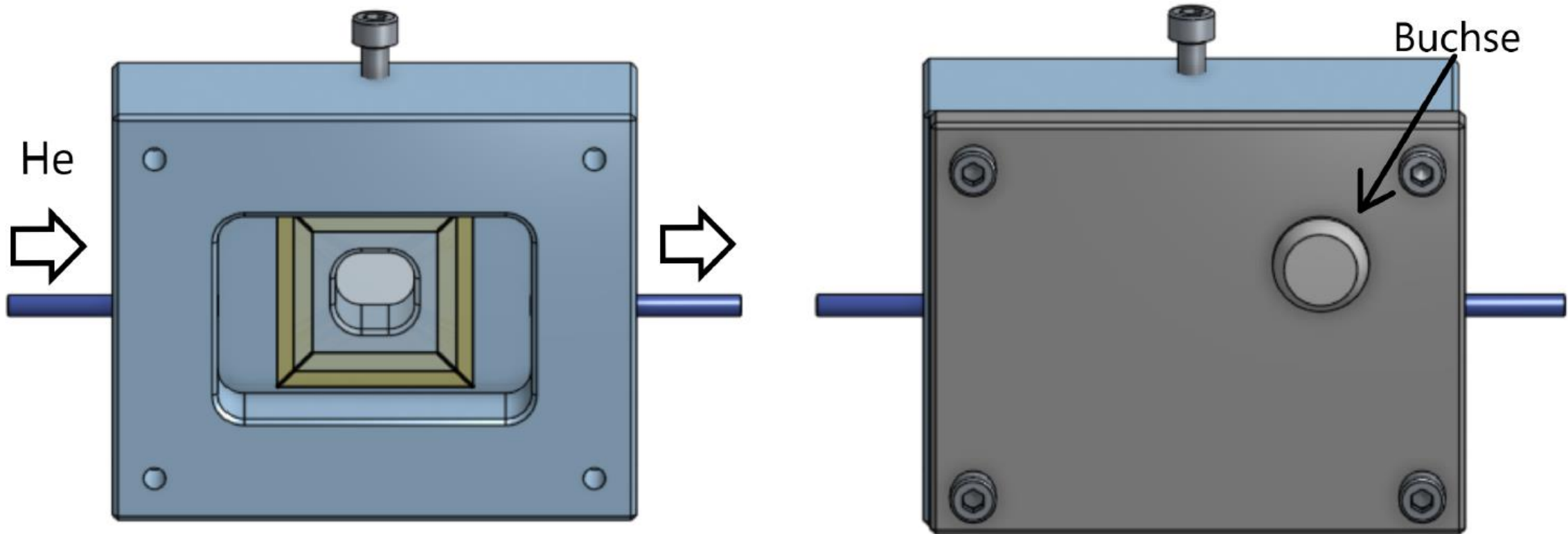

Final design

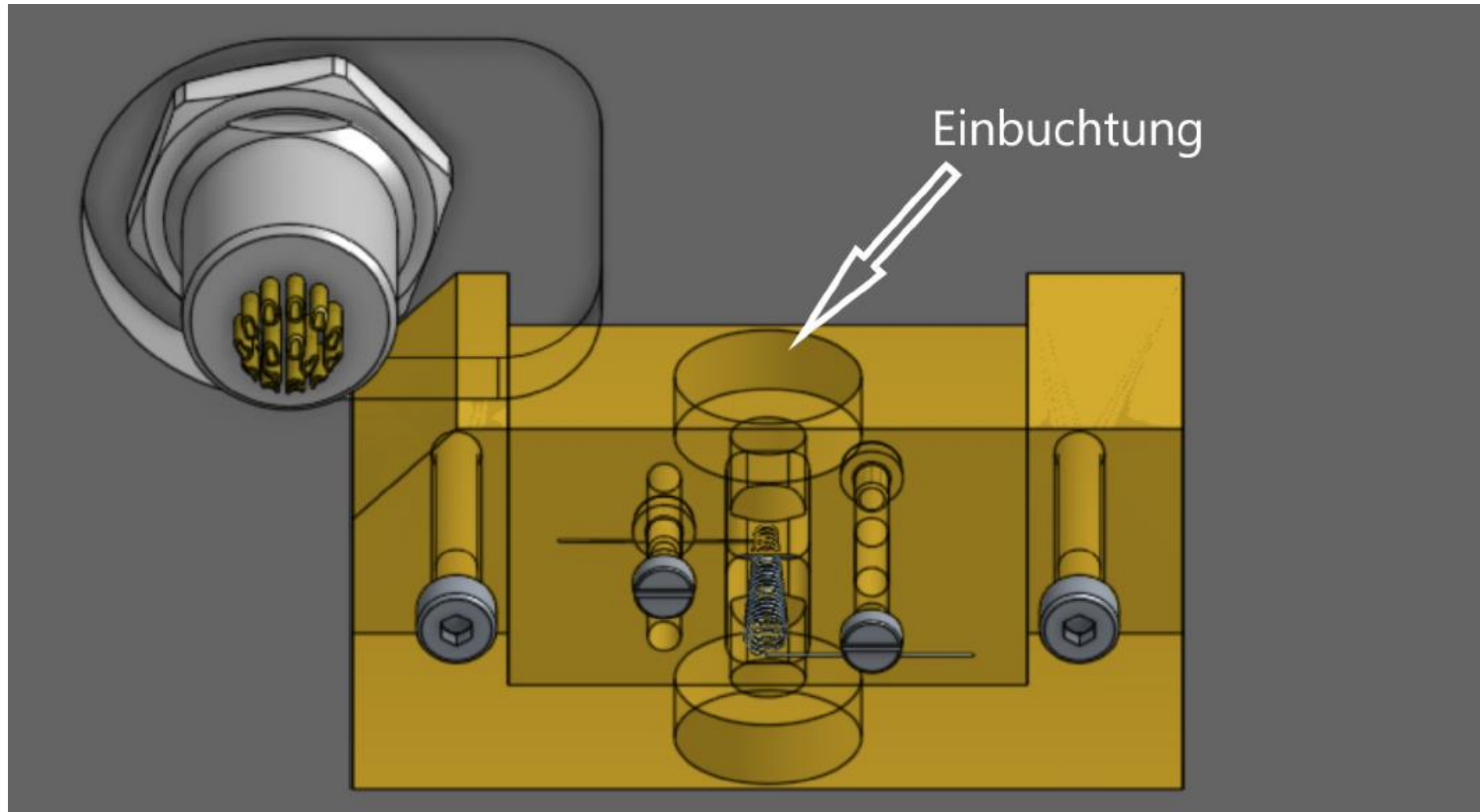

Heat control: the input sensors

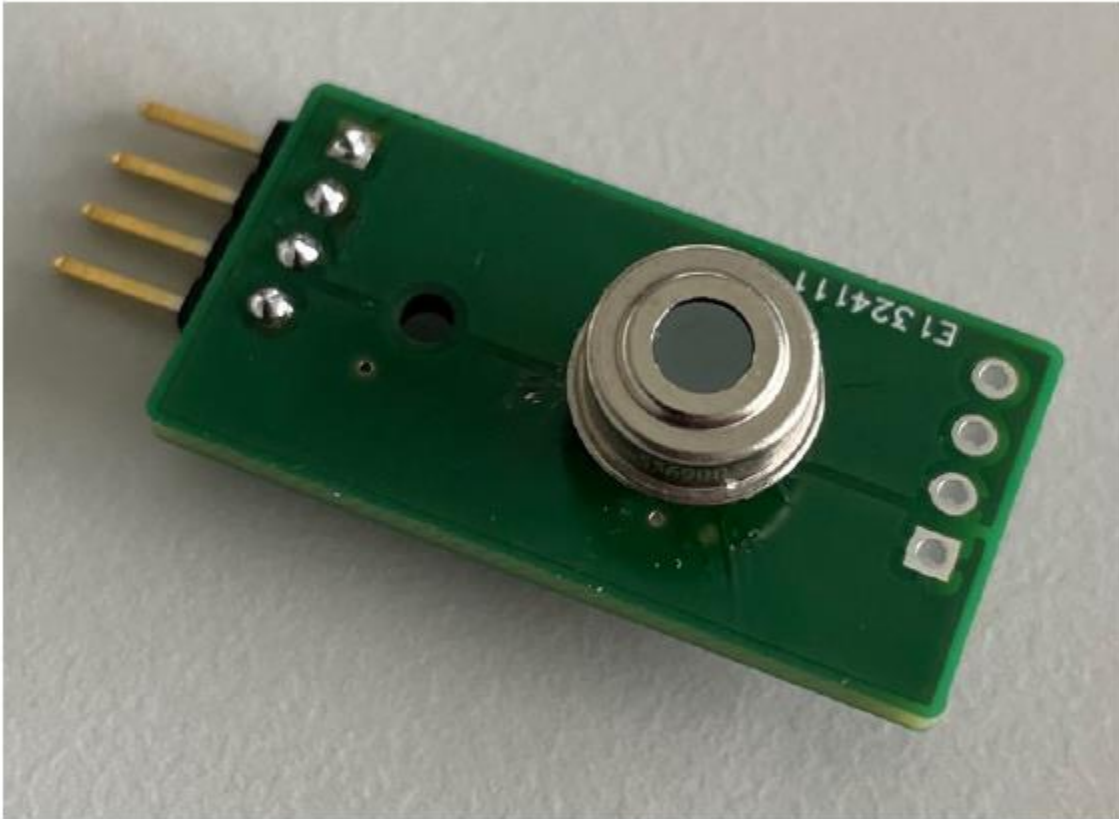

The first result and discussion

- Heat control worked as expected

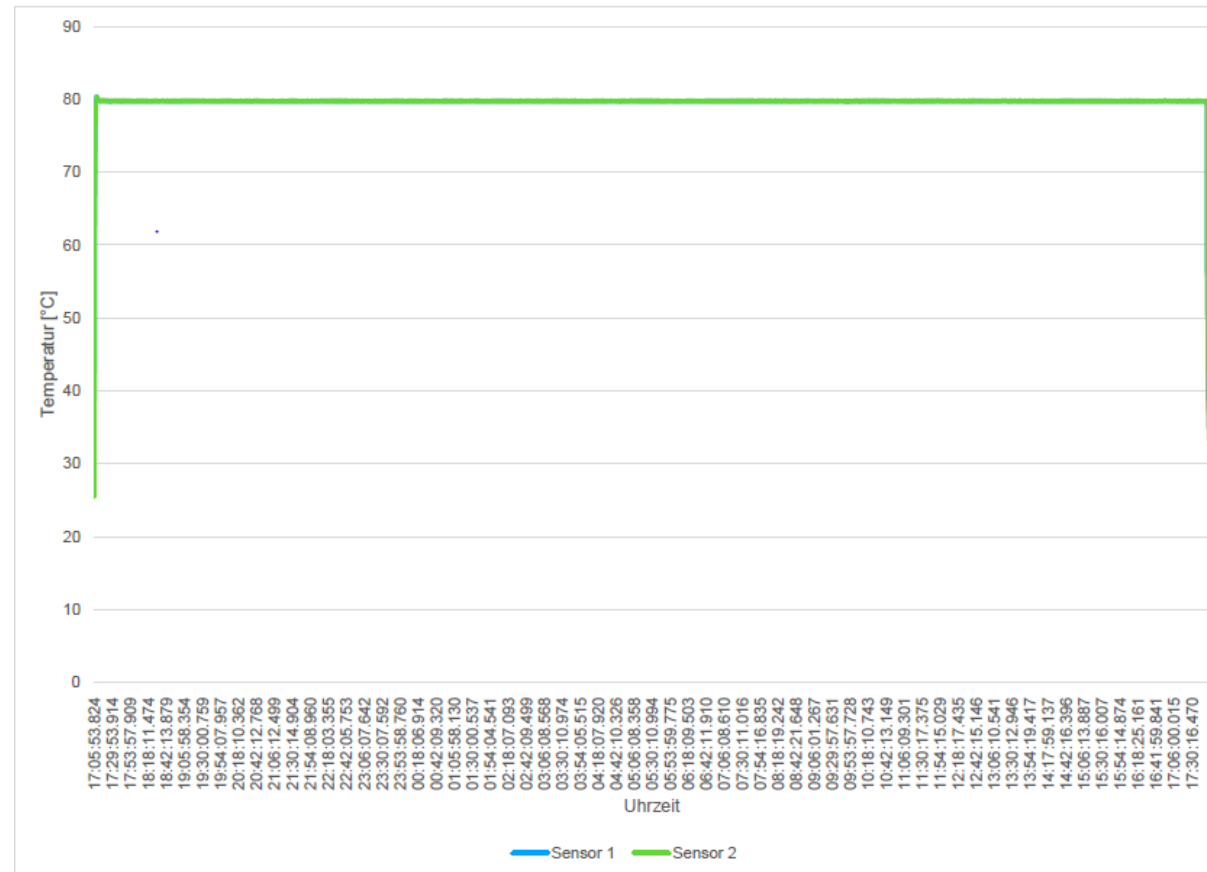

The first result and discussion

- Heat control worked as expected
- Kapton did not showed any damage after > 1 day



- Further plans: extend the measurement for at least ten days

My thanks go to...

... you listeners

... the Mu3e collaboration

... especially my semester thesis advisor Frank Meier

Backup

Caution: cables and wires ;)



Measurements
in
course!

-D4
bin off

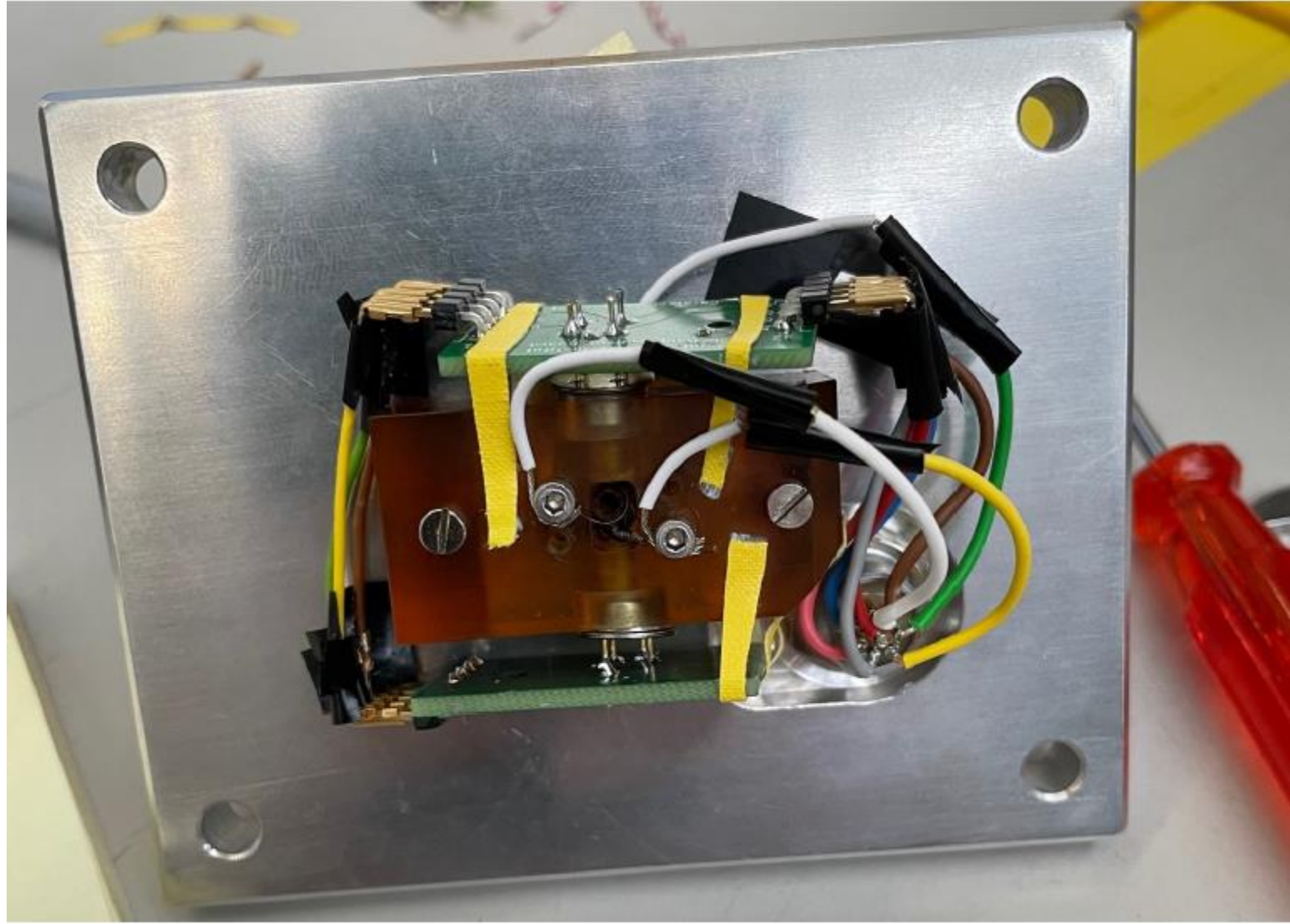

Chemical reaction (Kapton)

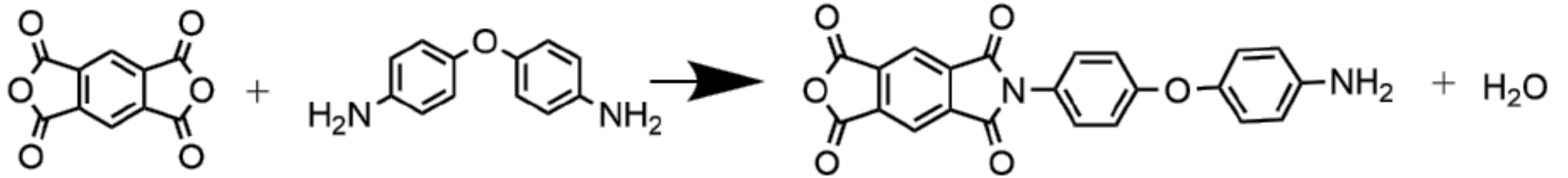

Mu3e Targets

a)

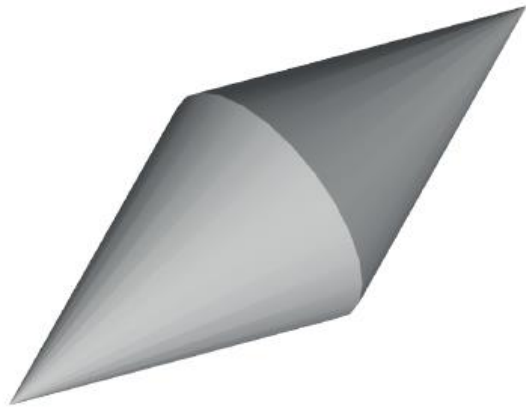

b)

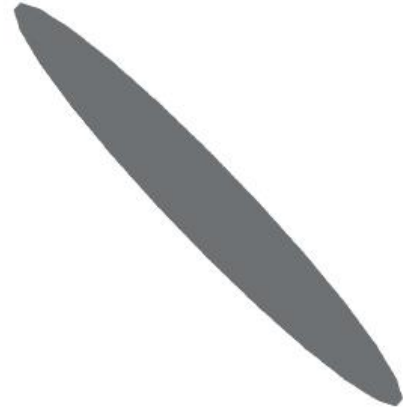

c)



d)



Sensor: MLX 90614

