

RELEASE STATUS		WIP	
WELDING SPEC		---	
MATERIAL SPEC		---	
MATERIAL		---	
TOLERANCES UNLESS OTHERWISE STATED			
LINEAR DIMENSIONS UP TO		xxx ± xxx	OVER xxx ± xxx
ANGULAR DIMENSIONS		± xxx°	
SCALE		0 500	
		1:5 ALL DIMENSIONS IN mm UNLESS OTHERWISE STATED	
DRN.	SCA	SCIENCE AND TECHNOLOGY FACILITIES COUNCIL	
DATE.	05/12/2012	DARESBUURY LABORATORY	
		CHESHIRE	
CKD.	BDF	TITLE	
DATE.	05/12/2012	SWISS FEL LASER HEATER UNDULATOR	
APPD.	BDF		
DATE.	--/--/--		
DRAWING NO.		SHEET 1 OF 4	
AI 256-III10		ISSUE	
		A	
SOLID EDGE CAD PART NO.		256-III10.asm ON LINE CLOSED	
USED ON		SWISS FEL/CLARA	
CONTRACTORS COMPANY		---	
CONTRACTORS DRG NO.		---	

THIS DRAWING IS THE PROPERTY OF STFC AND MAY NOT BE COPIED OR USED FOR ANY PURPOSE OTHER THAN THAT FOR WHICH IT IS SUPPLIED WITHOUT THE EXPRESS WRITTEN AUTHORITY OF STFC.

FIRST ISSUE

A

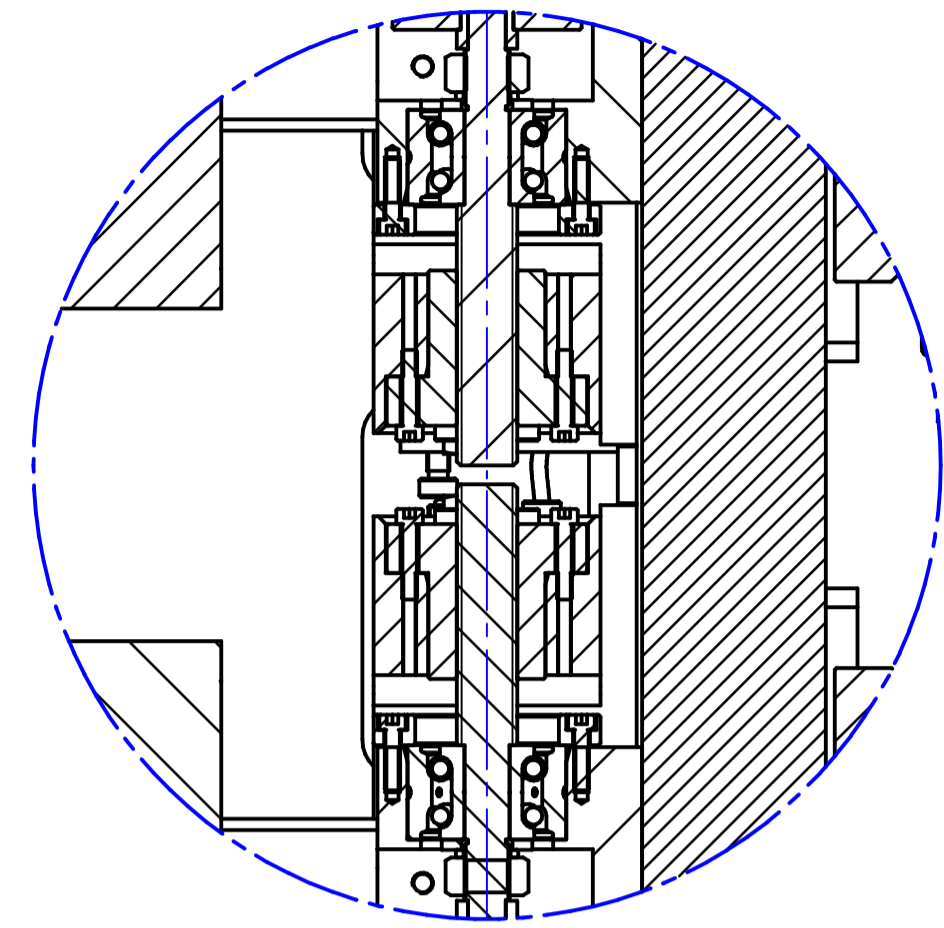

DETAIL C

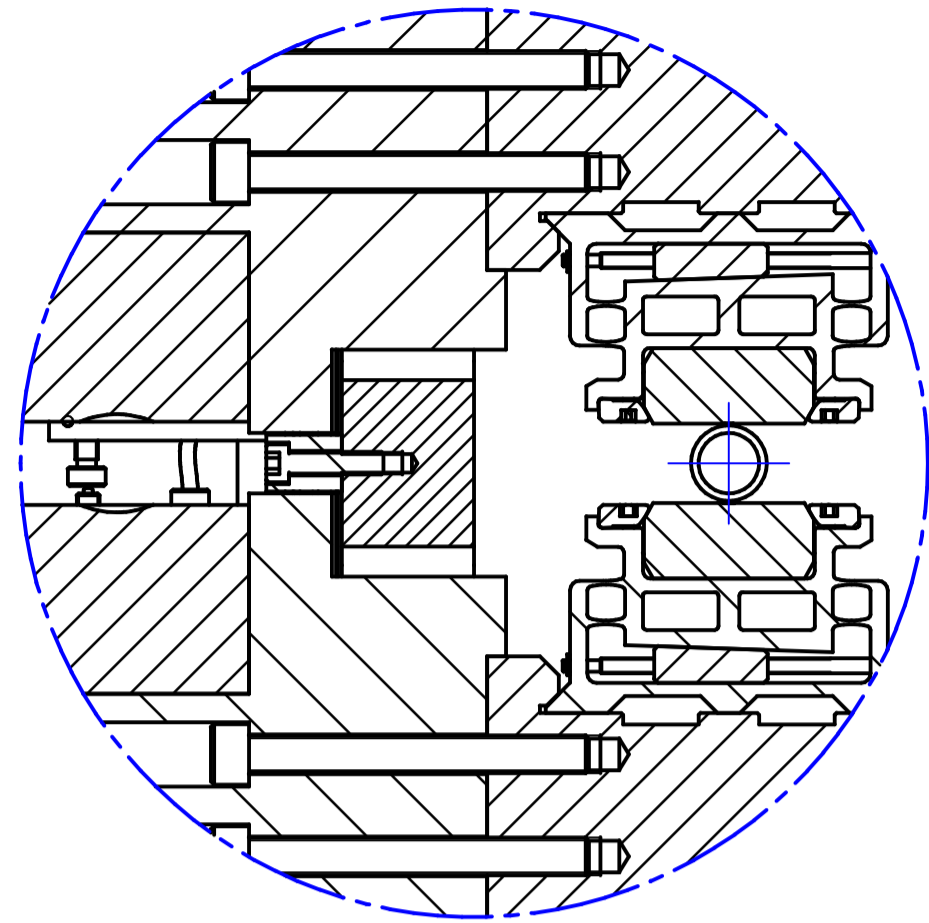

DETAIL D

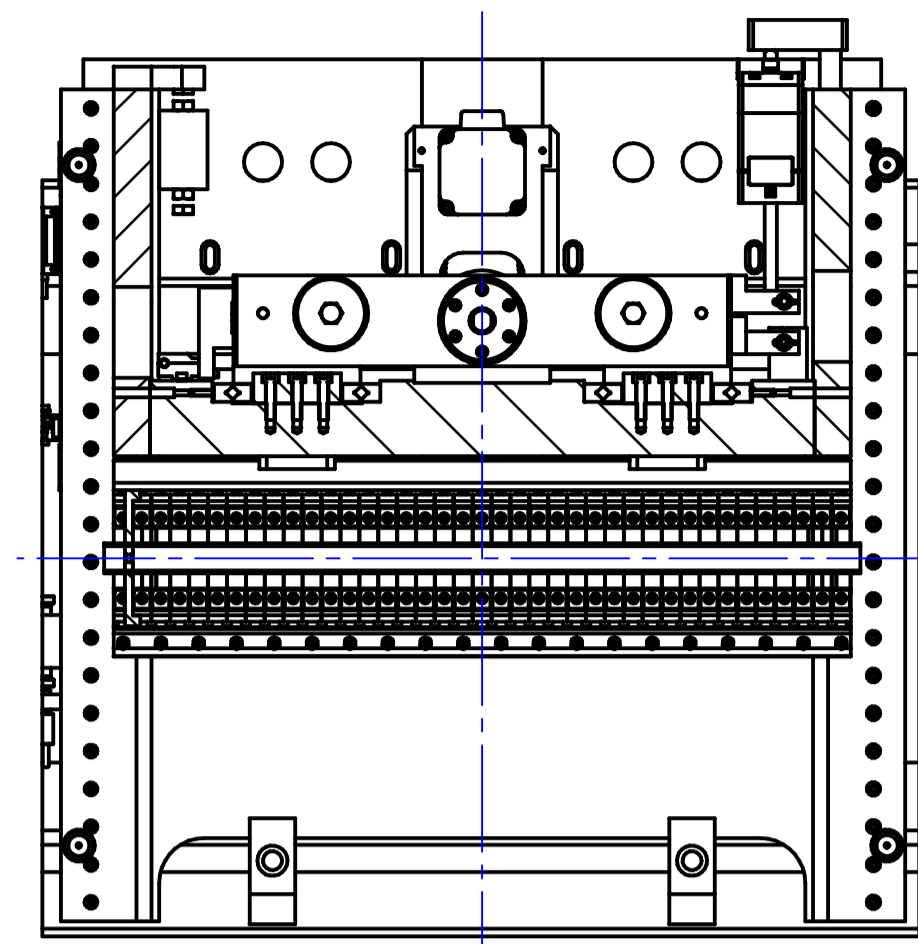

SECTION E-E

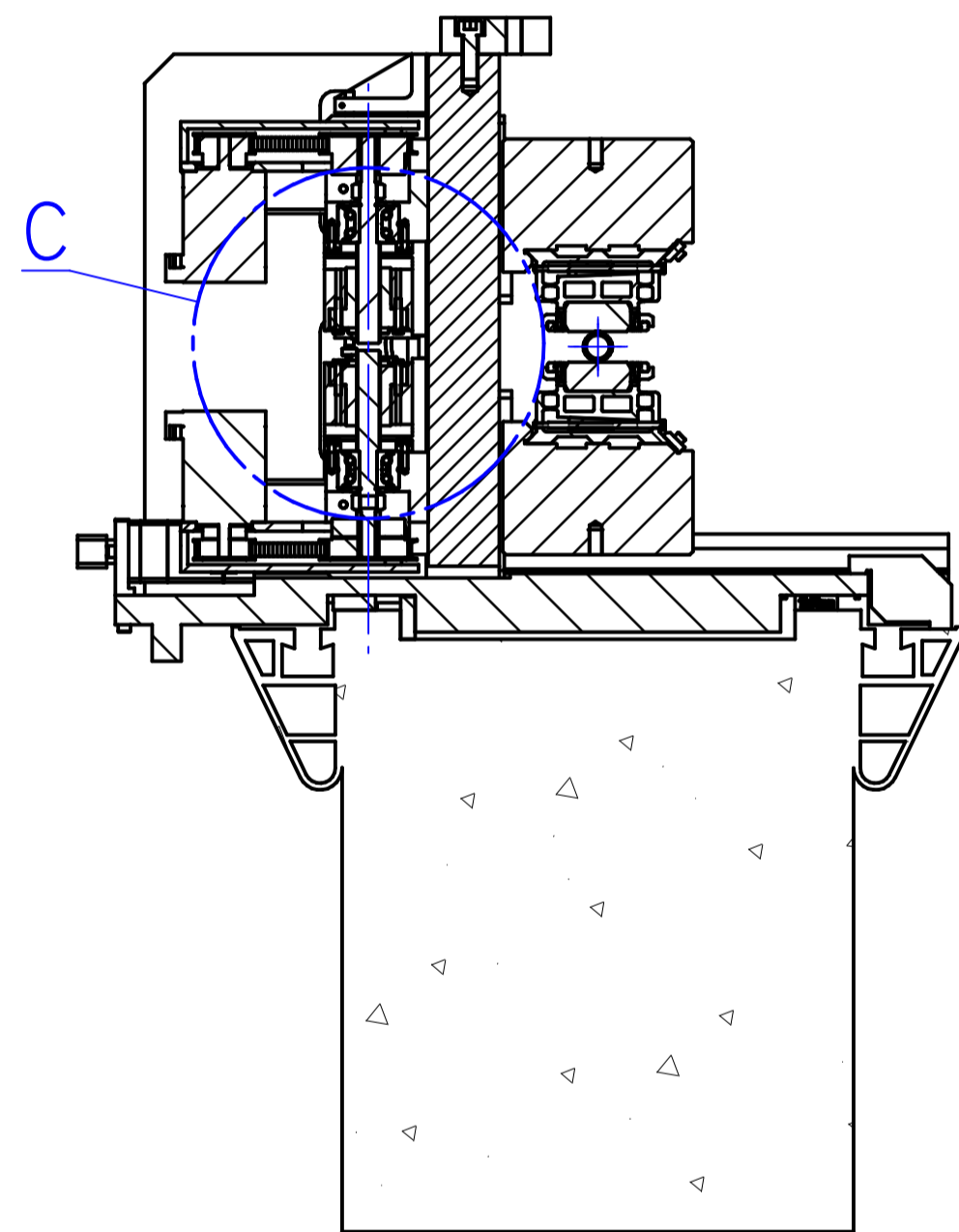

SECTION A-A

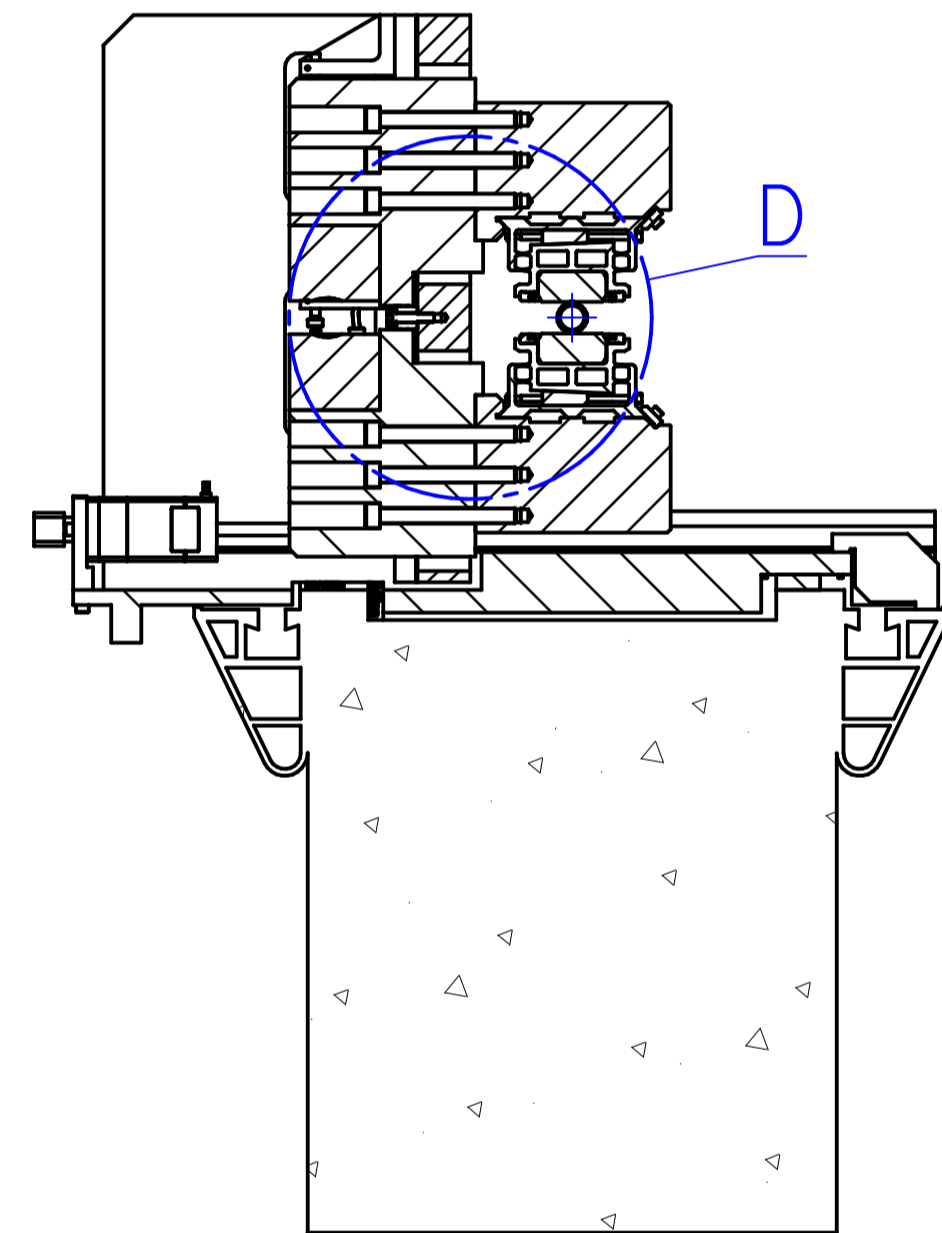

SECTION B-B

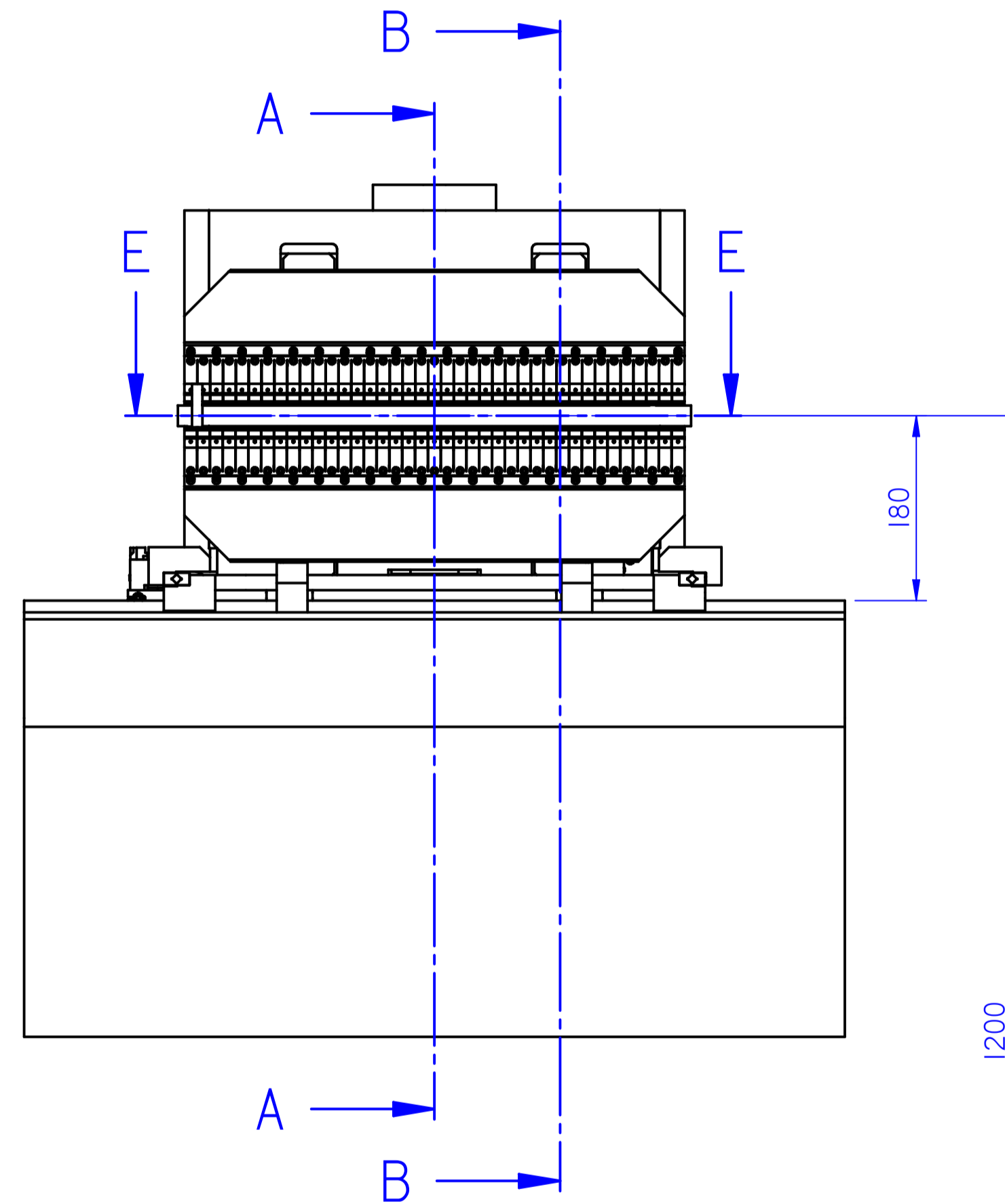

RELEASE STATUS		WIP	
WELDING SPEC		---	
MATERIAL SPEC		---	
MATERIAL		---	
TOLERANCES UNLESS OTHERWISE STATED			
LINEAR DIMENSIONS UP TO		xxx ± xxx	OVER xxx ± xxx
ANGULAR DIMENSIONS		± xxx°	
SCALE 1:5 			
ALL DIMENSIONS IN mm UNLESS OTHERWISE STATED			
DRN.	SCA	SCIENCE AND TECHNOLOGY FACILITIES COUNCIL	
DATE.	05/12/2012	DARESBUURY LABORATORY	
		CHESHIRE	
CKD.	BDF	TITLE	
DATE.	05/12/2012	SWISS FEL LASER HEATER UNDULATOR	
APPD.	BDF		
DATE.	--/--/--		
DRAWING NO.		SHEET 2 OF 4	
AI 256-11110		ISSUE	
		A	
SOLID EDGE CAD PART NO. 256-11110.asm ON LINE CLOSED			
USED ON		SWISS FEL/CLARA	
CONTRACTORS COMPANY		---	
CONTRACTORS DRG NO.		---	

THIS DRAWING IS THE PROPERTY OF STFC AND MAY NOT BE COPIED OR USED FOR ANY PURPOSE OTHER THAN THAT FOR WHICH IT IS SUPPLIED WITHOUT THE EXPRESS WRITTEN AUTHORITY OF STFC.

FIRST ISSUE

A

DRG NO. AI 256-11110 SHEET 3 OF 4

DRG. PRACTICE TO B.S. 308. THIRD ANGLE PROJECTION

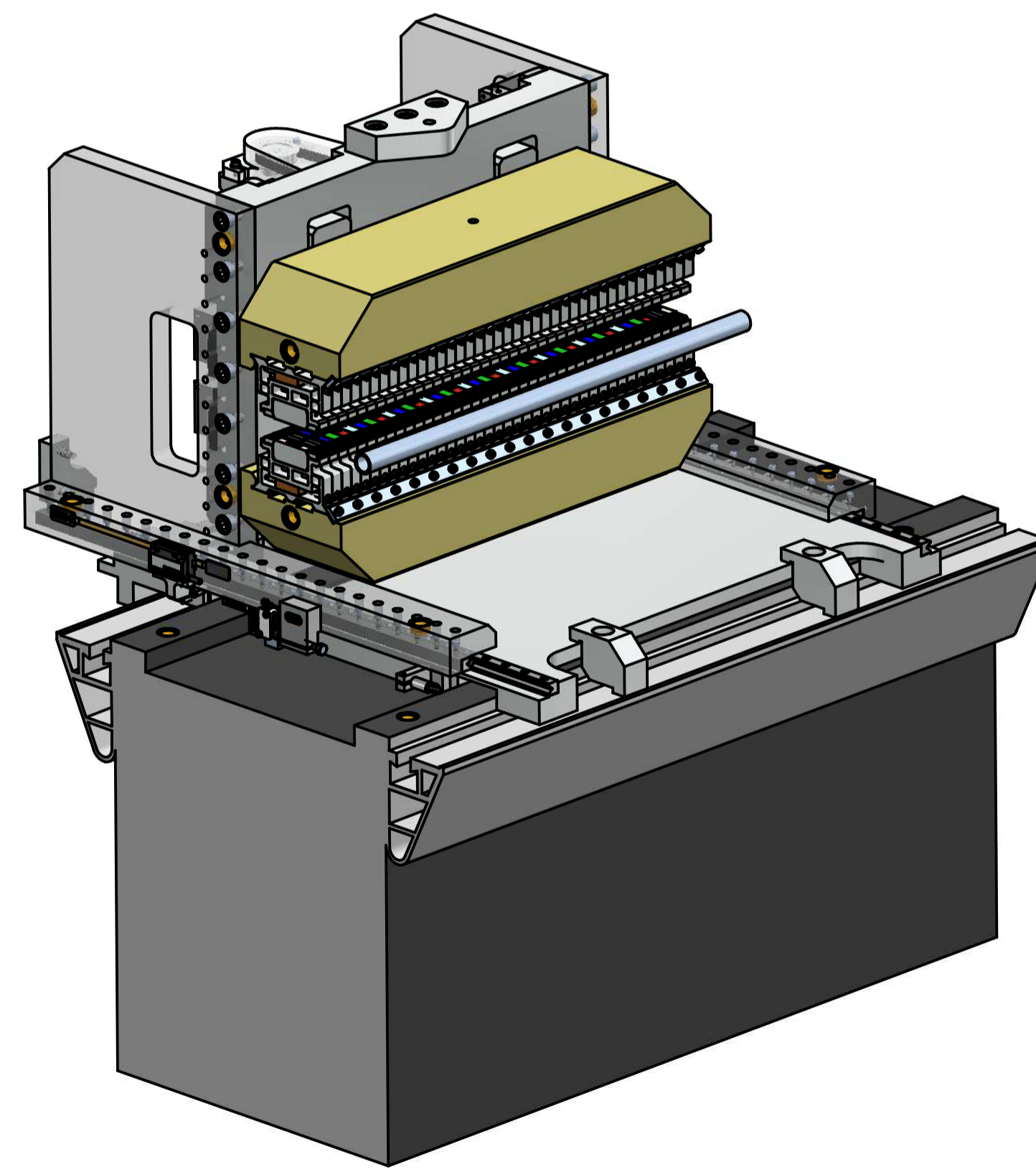
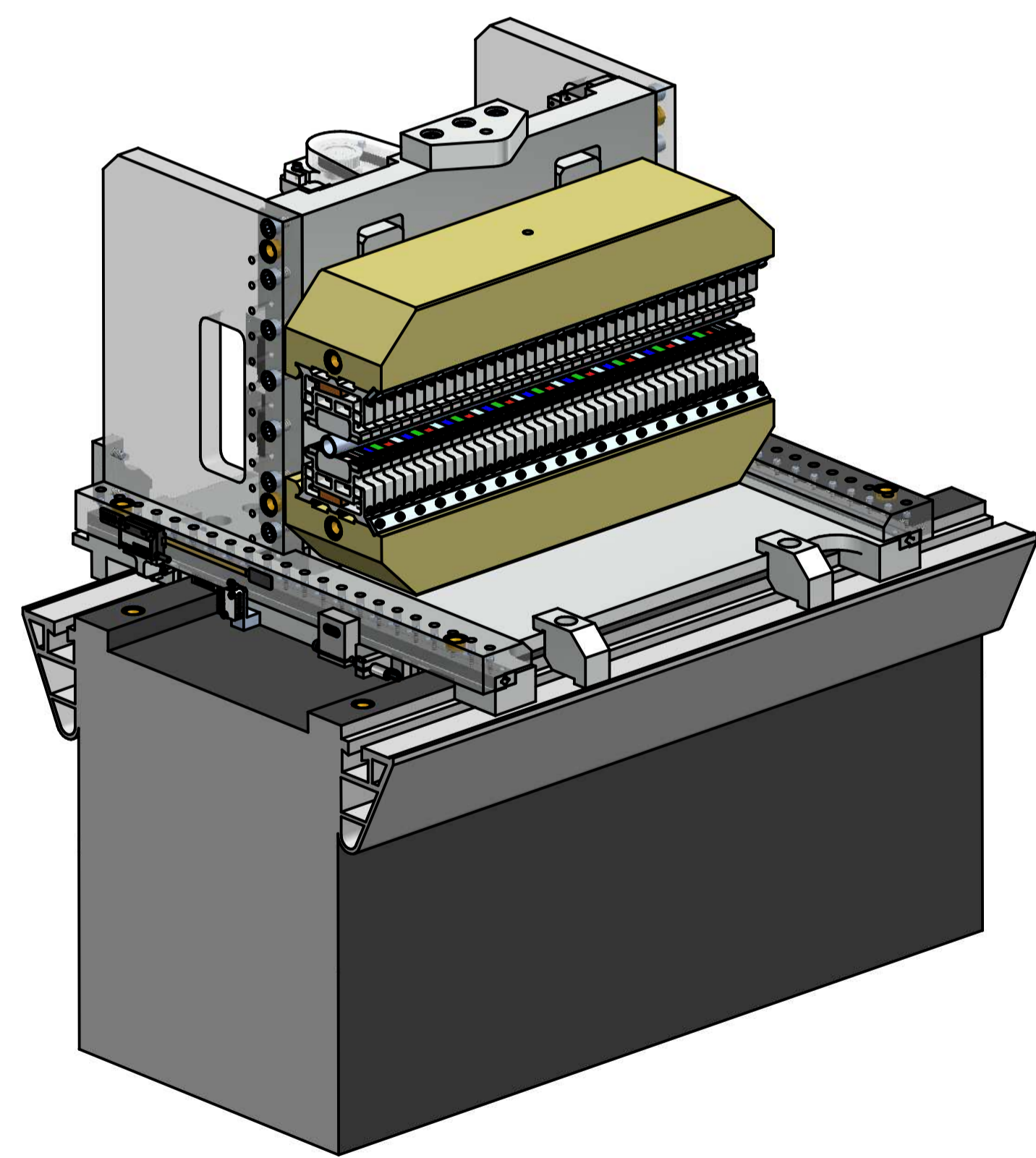
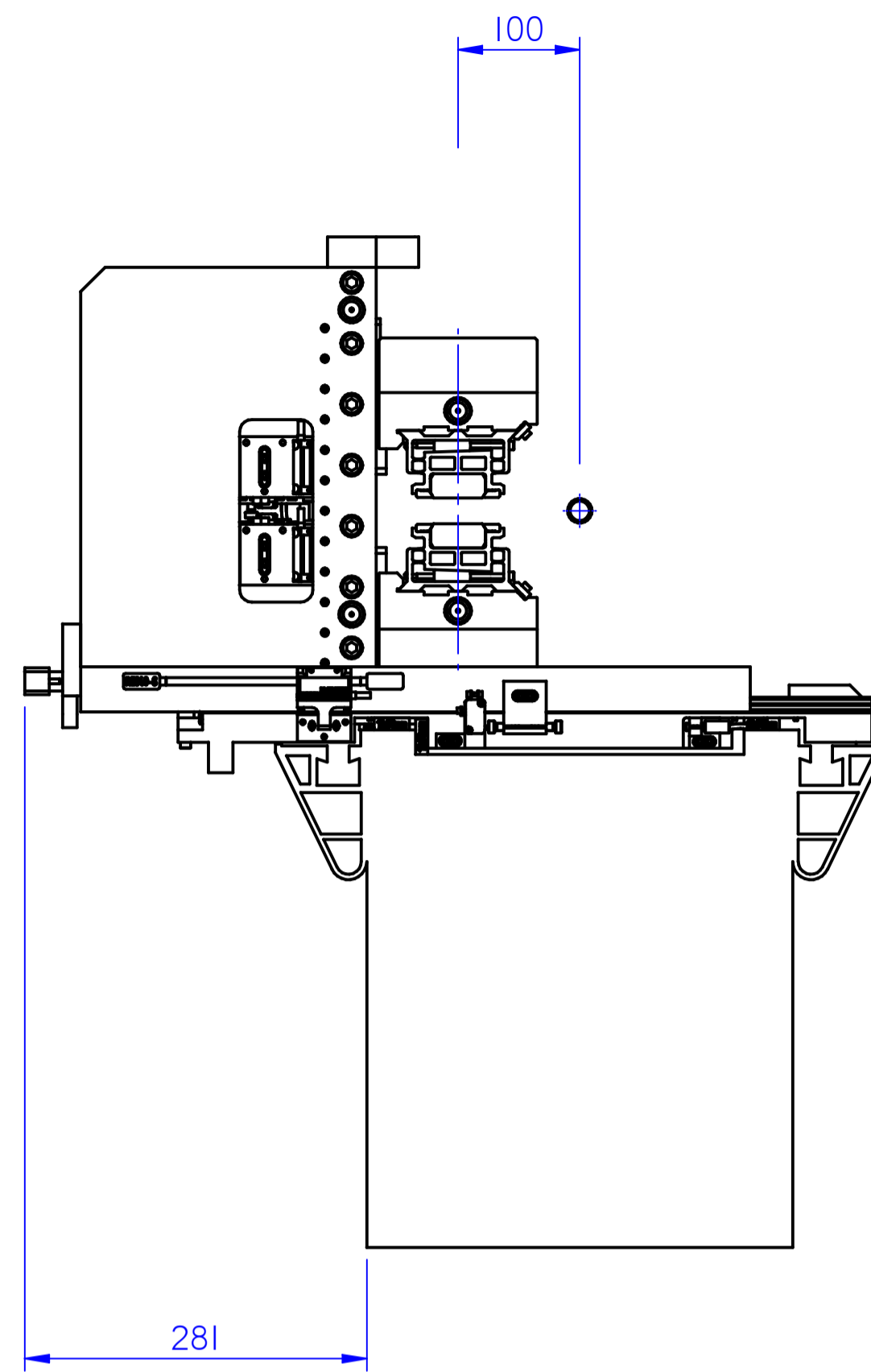
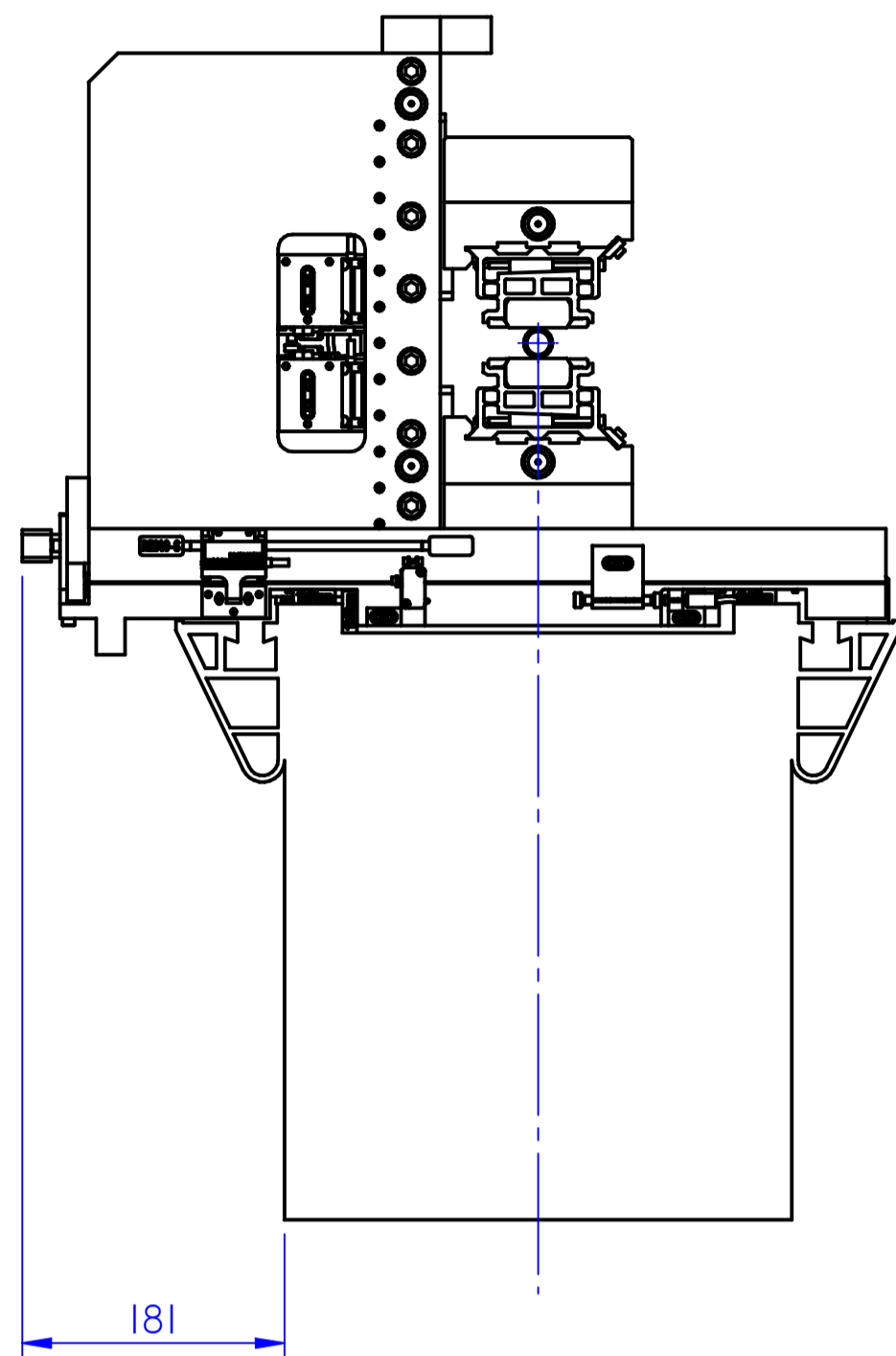

RELEASE STATUS		WIP	
WELDING SPEC		---	
MATERIAL SPEC		---	
MATERIAL		---	
TOLERANCES UNLESS OTHERWISE STATED			
LINEAR DIMENSIONS UP TO		xxx ± xxx	OVER xxx ± xxx
ANGULAR DIMENSIONS		± xxx°	
SCALE 1:5			
0 500 ALL DIMENSIONS IN mm UNLESS OTHERWISE STATED			
DRN.	SCA	SCIENCE AND TECHNOLOGY FACILITIES COUNCIL	
DATE.	05/12/2012	DARESBUURY LABORATORY	
		CHESHIRE	
CKD.	BDF	TITLE	
DATE.	05/12/2012	SWISS FEL LASER HEATER UNDULATOR	
APPD.	BDF		
DATE.	--/--/--		
DRAWING NO.		SHEET 3 OF 4	
AI 256-11110		ISSUE	
		A	
SOLID EDGE CAD PART NO. 256-11110.asm ONLINE CLOSED			
USED ON		SWISS FEL/CLARA	
CONTRACTORS COMPANY		---	
CONTRACTORS DRG NO.		---	

THIS DRAWING IS THE PROPERTY OF STFC AND MAY NOT BE COPIED OR USED FOR ANY PURPOSE OTHER THAN THAT FOR WHICH IT IS SUPPLIED WITHOUT THE EXPRESS WRITTEN AUTHORITY OF STFC.

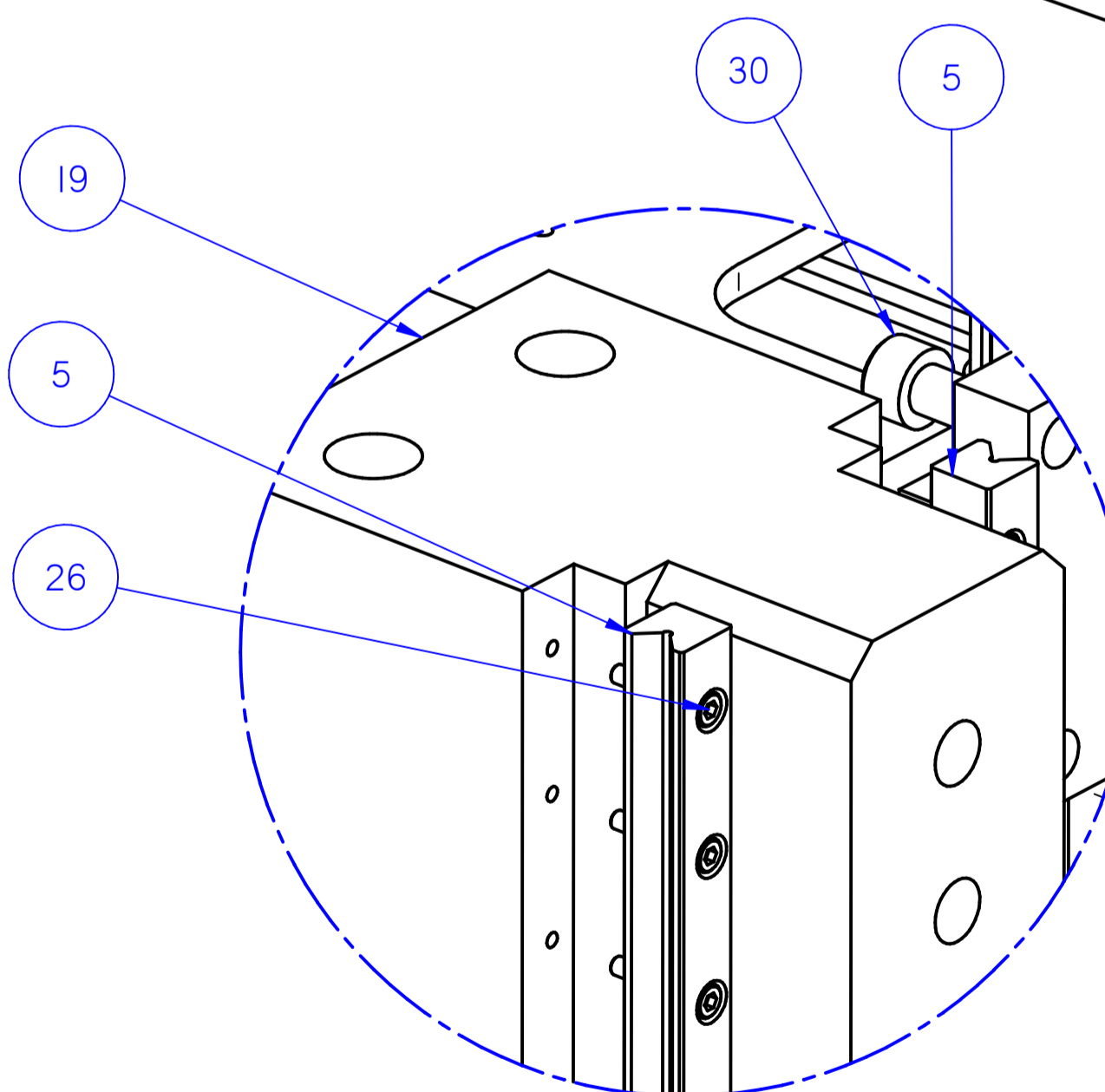
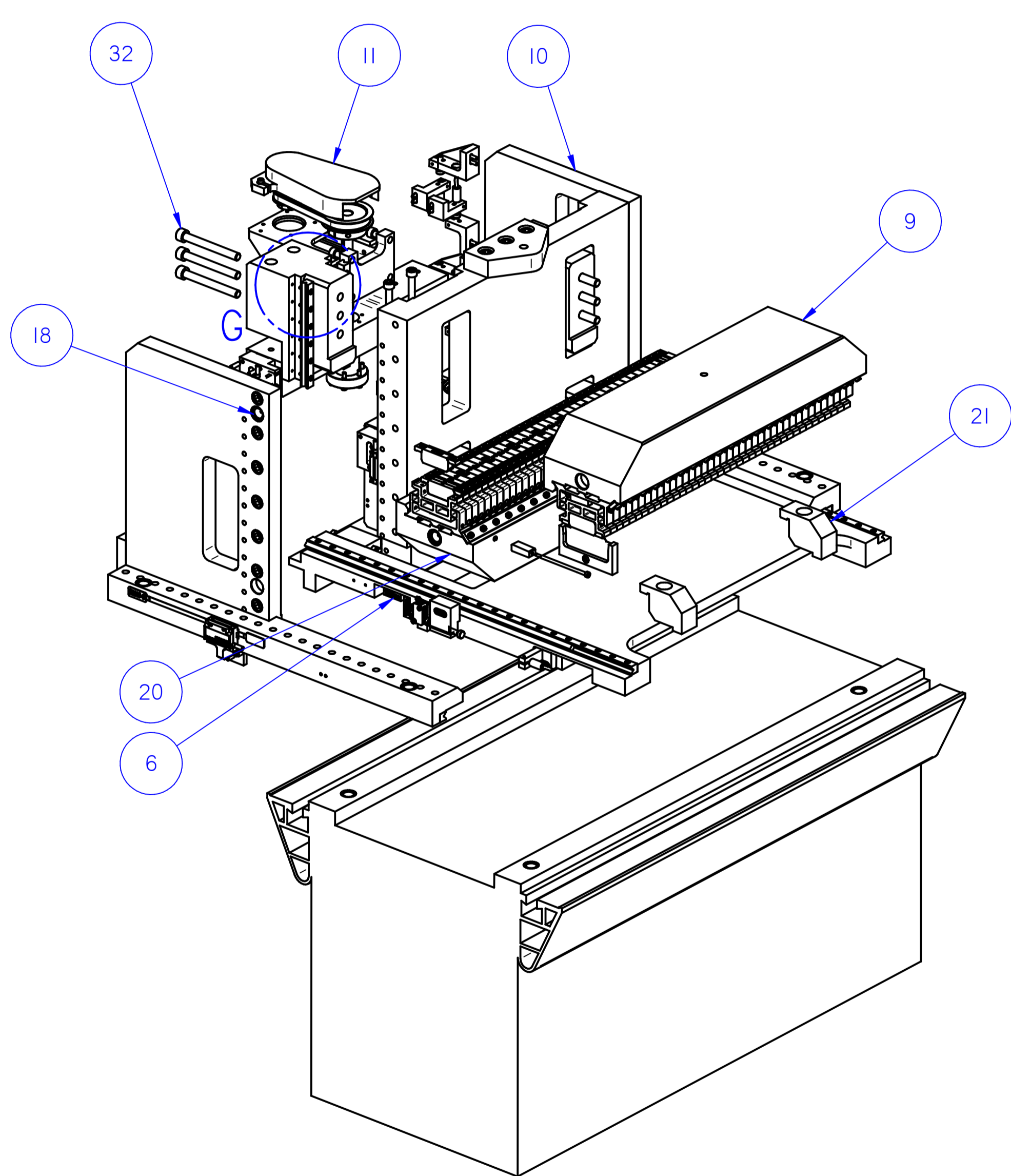
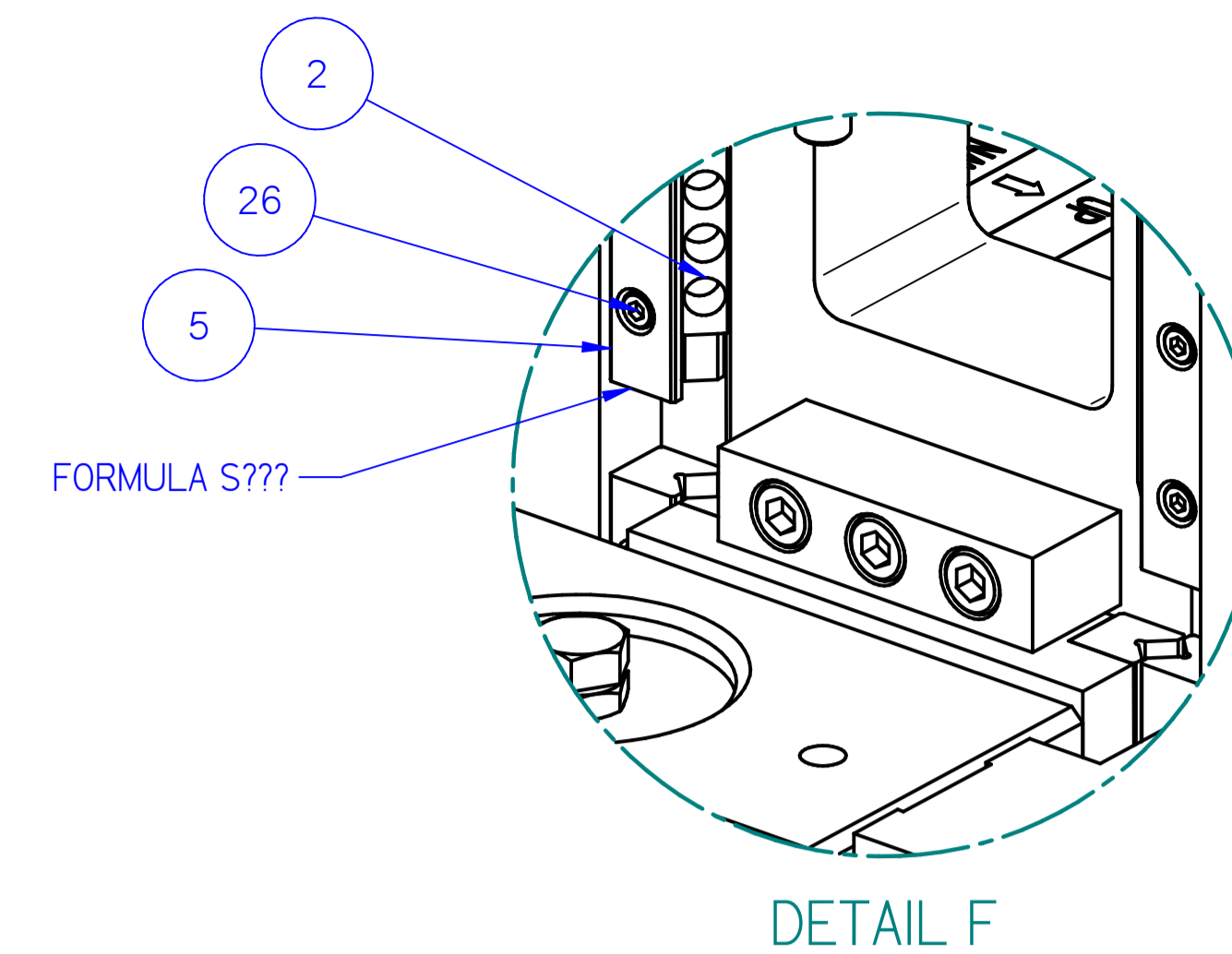
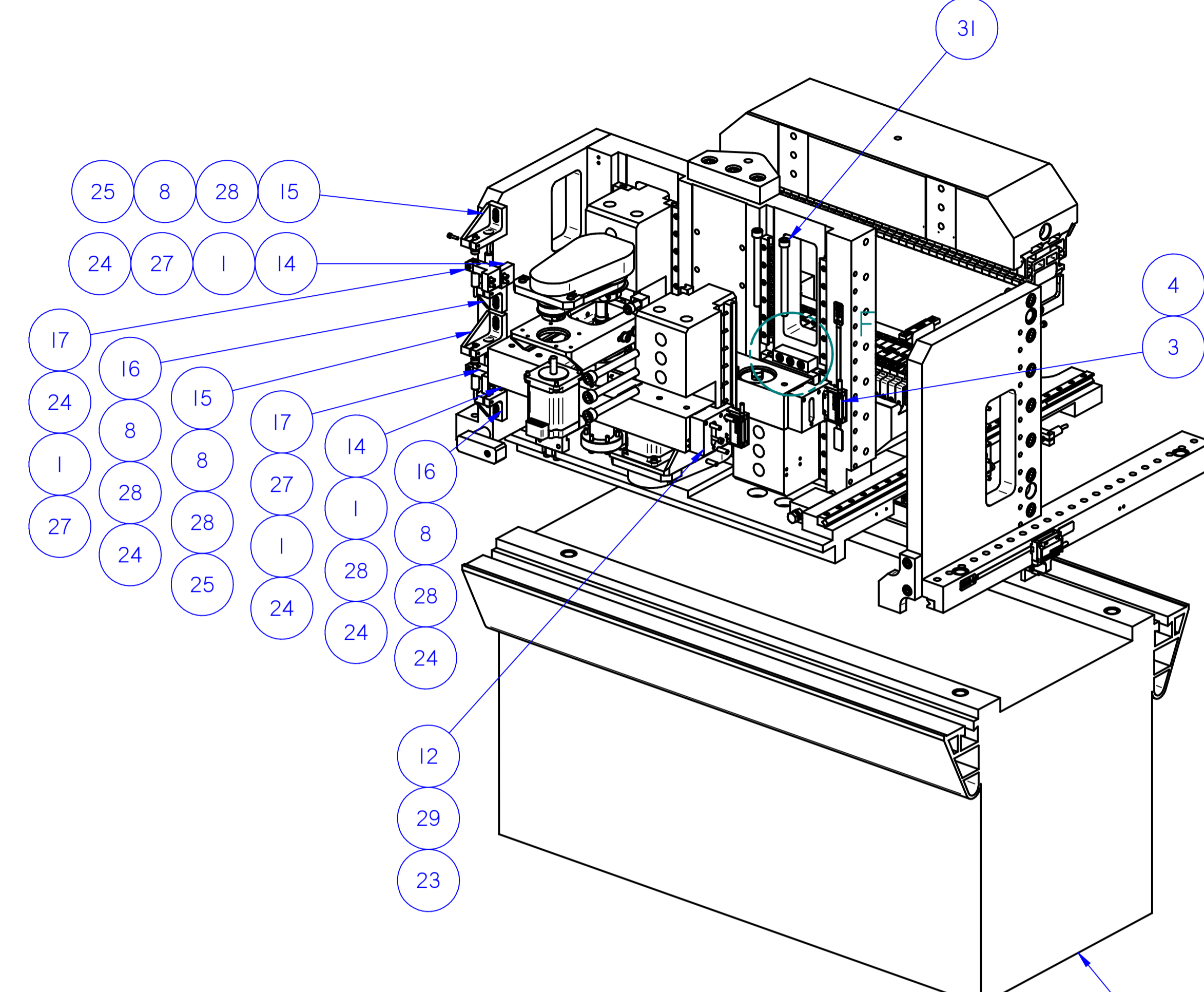

Ref	Drg No	Title	QTY
1	001-13647	MY-COM-E 341-424 POS SWITCH	4
2	001-13662	SCHNEEBERGER KBS 6 130LNG	8
3	001-13664	RENISHAW RGH41T30005A	2
4	001-13700	RG40-S A-9537-4008	1
5	001-13711	SCHNEEBERGER RNG 6 150LNG	16
6	001-13781	10MM SLIP GAUGE	8
8	256-11121	THUMB SCREW	4
9	256-11125	LASER HEATER TOP MAGNET ASSEMBLY	1
10	256-11135	HORIZONTAL DRIVE ASSEMBLY	1
11	256-11145	LEAD SCREW DRIVE ASSEMBLY	2
12	256-11153	ENCODER BRACKET TYPE 1	2
13	256-11156	SUPPLIED GRANITE BLOCK	1
14	256-11392	LIMIT SWITCH STOP BRACKET	2
15	256-11393	LIMIT SWITCH STOP BRACKET	2
16	256-11394	LIMIT SWITCH STOP BRACKET	2
17	256-11395	LIMIT SWITCH STOP BRACKET	2
18	256-11400	SWISS FEL SURVEY MOUNT	16
19	256-11401	GIRDER SUPPORT ARM	4
20	256-11470	BOTTOM MAGNET ASSEMBLY	1
21	256-11532	BASE CLAMP	2
23	GS1-050-016	GRUB SCREW M5x16	6
24	SHS-030-010	M3 x 10 LG SKT HD CAP SCREW	4
25	SHS-030-012	M3 x 12 LG CAP SCREW	4
26	SHS-030-016	M3 x 16 LG SKT HD CAP SCREW	100
27	SHS-040-012	M4 x 12 LG SKT HD CAP SCREW	8
28	SHS-040-016	M4 x 16 LG SKT CAP HD SCREW	8
29	SHS-040-020	M4 x 20 LG SKT CAP HD SCREW	4
30	SHS-080-020	M8 x 20 LG SKT HD CAP SCREW	8
31	SHS-080-100	M8 x 100LG SKT HD CAP SCREW	8
32	SHS-100-090	M10 x 90 LG SKT HD CAP SCREW	12

RELEASE STATUS	WIP		
WELDING SPEC	---		
MATERIAL SPEC	---		
MATERIAL	---		
TOLERANCES UNLESS OTHERWISE STATED			
LINEAR DIMENSIONS UP TO	xxx ± xxx	OVER	xxx ± xxx
ANGULAR DIMENSIONS	± xxx°		
SCALE	1:5		
ALL DIMENSIONS IN mm UNLESS OTHERWISE STATED			

DRN.	SCA	SCIENCE AND TECHNOLOGY FACILITIES COUNCIL	
DATE.	05/12/2012	DARESBUARY LABORATORY	
CKD.	BDF	CHESHIRE	
DATE.	05/12/2012	TITLE	
APPD.	BDF	SWISS FEL LASER HEATER UNDULATOR	
DATE.	--/--		
DRAWING NO.		SHEET 4 OF 4	ISSUE
AI 256-11110			A
SOLID EDGE CAD PART NO. 256-11110.asm ON LINE CLOSED			
USED ON		SWISS FEL/CLARA	
CONTRACTORS COMPANY		---	
CONTRACTORS DRG NO.		---	

THIS DRAWING IS THE PROPERTY OF STFC AND MAY NOT BE COPIED OR USED FOR ANY PURPOSE OTHER THAN THAT FOR WHICH IT IS SUPPLIED WITHOUT THE EXPRESS WRITTEN AUTHORITY OF STFC.